

## APPROVAL PAGE

We, undersigned state that this manual and its contents are in compliance with requirements of Turkish DGCA, ICAO, IATA, EASA and other relevant, applicable national and international regulations.

### Prepared by:



Atilay BATU  
Chief Operating Officer

### Reviewed by:

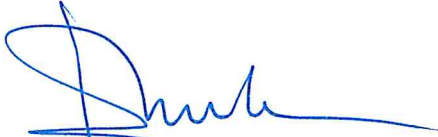

Emre KÖK  
Chief Compliance Monitoring Officer

### Approved by:



Yıldırım KARAER  
Accountable Manager



## GROUND OPERATION MANUAL

Doc Code: CA-GOP-GOM

Rev No: 45

Rev Date: 01 APR 2026

Page: 2

---

**INTENTIONALLY LEFT BLANK**

**RECORD OF REVISIONS PAGE**

Rev No.	Edited/Amended Page(s)	Revision Date
1	Complete Revision	19 April 2006
2	iii, iv, v, vi, 1-9, 1-10, Chapter 3	01 May 2007
3	iii, iv, v, vi, 1-9, 1-10, 2-13, 2-25, 2-28, 2-36, 4-3, 4-4, 4-5	15 Nov 2007
4	iii, iv, v, vi, 1-4, 1-5, 1-6, 1-7, 1-8, 1-9, Chapter 2, 3-10, 8-4, 8-5, Chapter 10,	01 Feb 2008
5	Complete Revision	01 Nov 2008
5a	iii, iv, v, vi, vii, 2-36	11 Feb 2009
5b	iii, iv, v, vi, vii, 3-10, 3-14	05 Mar 2009
6	Introduction, Chapter 1-3, Chapter 2-3, 2-4, 2-5, 2-11, 2-12, 2-13, 2-14, 2-15, 2-18, 2-19, 2-23, 2-25, 2-26, 2-29, 2-38, Chapter 3, Chapter 5-2 Chapter 10	01 Oct 2009
7	Introduction, Chapter 2-20, 2-26, 2-27, 2-28, 2-30, 2-33, Ch. 3-5, 3-6, 3-8, 3-10, 3-11, 3-12, 3-15, Ch. 6-6, 6-7, 6-10	26 Mar 2010
8	Introduction, Chapter 1-2, 2-5, 2-17, 2-30, 3-4, 3-8, 3-10, 3-5, 3-12, 5-2	18 Oct 2010
8a	Introduction, Chapter 1-7	07 Mar 2011
9	Introduction, Chapter 1-2, 1-7, 1-8, 1-9, 2-5, 2-18, 2-19, 2-20, 3-5, 3-6, 8-4, 8-5	24 May 2011
10	Introduction, Chapter 1, Chapter 2-5, Chapter 3-12, 3-13, 3-14, 3-15, 3-16, 3-17, 3-18, 3-19, 3-30, 3-32, 3-33, 3-39, 3-41, 3-42, 3-43, 3-44,	19 Oct 2011
11	Complete Revision	06 Mar 2012
11a	Introduction, Chapter 1-4, 1-12, 3-6, 3-7	10 Jul 2012
11b	Introduction, Chapter 1.1.2, 1.6, 2.35, 2.36,	07 Aug 2012
12	Introduction, Chapter 2	08 Oct 2012
12a	Introduction, Chapter 1.9, 3.1.5, 3.2.1	07 Feb 2013
12b	Introduction, Chapter 8	10 May 2013
13	Complete Revision	01 May 2014
13a	Introduction,	25 Jul 2013
14	Complete Revision	01 May 2014
15	Complete Revision	12 Nov 2014
15a	New Logo of the Company is added	01 Jun 2015
16	Complete Revision due to revision of IGOM	01 June 2015

17	Introduction, Chapter 11	10 Aug 2015
18	Complete Revision	25 Nov 2016
18a	Introduction, Chapter 1, Chapter 4, Chapter 7, Chapter 8	08 Feb 2017
19	Introduction, Chapter 2, Chapter 3, Chapter 4, Chapter 7, Chapter 8	04 Oct 2017
20	Complete Revision	16 Feb 2018
20a	Introduction, Chapter 1	01 Mar 2018
21	Introduction, Chapter 1 Chapter 2, Chapter 3, Chapter 4, Chapter 6, Chapter 7, Chapter 8, Chapter 10	05 Oct 2018
22	Chapter 2, Chapter 4	31 Dec 2018
23	Chapter 7	28 Feb 2019
23a	Chapter 1, Chapter 2	31 May 2019
24	Chapter 1, Chapter 2, Chapter 3	18 Jun 2019
24a	Chapter 1	29 Aug 2019
25	Chapter 1, Chapter 2, Chapter 3, Chapter 7, Chapter 8, Chapter 10	16 Dec 2019
26	Chapter 2, Chapter 4, Chapter 10	10 Jul 2020
27	Chapter 1, Chapter 2, Chapter 3, Chapter 5, Chapter 7, Chapter 8, Chapter 10	30 Sep 2020
28	Chapter 2, Chapter 7, Chapter 10	01 Jan 2021
29	Chapter 1, Chapter 2, Chapter 3, Chapter 7, Chapter 8, Chapter 10	01 Jun 2021
30	Chapter2, Chapter 4, Chapter 7	25 Oct 2021
31	Distribution List, System Of Amendment And Revisions, Chapter 1, Chapter 2 ,Chapter 3, Chapter4, Chapter 5, Chapter 8, Chapter 10	27 Jan 2022
32	System Of Amendment And Revisions, Chapter 1, Chapter 2, Chapter 3	24 Jun 2022
33	Distribution List, Chapter 1, Chapter 2, Chapter 3, Chapter 4	10 Oct 2022
34	Chapter 1, Chapter 2, Chapter 3, Chapter 5, Chapter 7, Chapter 8, Chapter 10	27 Jan 2023
35	Chapter 1, Chapter 2, Chapter 3	26 May 2023
36	Chapter 1, Chapter 2, Chapter 11	16 Jun 2023
37	Chapter 1, Chapter 2, Chapter 3, Chapter 4, Chapter 8	06 Jul 2023
38	Chapter 1, Chapter 2, Chapter 3, Chapter 4, Chapter 10	01 Jan 2024
39	Chapter1, Chapter 2, Chapter 3, Appendix 18, Chapter 11	01 Apr 2024



# GROUND OPERATION MANUAL

Doc Code: CA-GOP-GOM

Rev No: 45

Rev Date: 01 APR 2026

Page: 5

40	Chapter 1, Chapter 3, Chapter 7, Chapter 8, Chapter 10	24 Jan 2025
41	Chapter1, Chapter 2, Chapter 3, Chapter 7, Chapter 8, Appendix 9, Appendix 12, Appendix 18	14 Mar 2025
42	Chapter1, Chapter 2, Chapter 3, Chapter 4, Chapter 5, Chapter 11	29 May 2025
43	Chapter 1, Chapter 7, Appendix 8	20 Jun 2025
44	Chapter 1, Chapter 1.5.1, Chapter 3.7.1,3.12.9, 7.3,7.5,7.8.2,7.8.5,7.8.7,7.8.8	01 Sep 2025
45	Chapter 2, Chapter3, Chapter 4, Chapter 7, Chapter 8, Appendix 16	01 Apr 2026

RETAIN THIS SHEET UNTIL NEW ISSUE

**REVISION HIGHLIGHTS****Revision No : 43****Revision Date : 20 Jun 2025**

1.1.1 Company Organizational Structure  
1.1.2 Ground Operations Department Organization Chart  
1.5.8 Training in case of Job Interruption  
7.9.1.1 Ground Operation Liaison  
Appendix-8 Seat Chart

**Revision No : 44****Revision Date : 01 Sep 2025**

Distribution list has been revised.  
Chapter 1 Retention of records have been revised.  
1.5.1 Training General has been revised.  
3.7.1 has been revised.  
3.12.9 has been revised.  
7.3.1 Emergencies Requiring the Evacuation of an Aircraft during Ground Handling has been added.  
7.5 has been revised.  
7.8.2 has been revised.  
7.8.5 has been revised.  
7.8.7 has been revised.  
7.8.8 has been revised.

**Revision No : 45****Revision Date : 01 Apr 2026**

Abbreviations has been revised.  
2.1.3 has been revised.  
2.1.5 has been revised.  
2.3.1 has been revised.  
2.3.5 has been revised.  
2.3.6 has been revised.  
2.4.3 has been revised.  
2.6.1 has been revised.  
3.2 and 3.2.1 has been revised.  
3.10.4. Turnaround Timeline and Phase Management has been added.  
3.12.9 has been revised.  
4.2.2 has been revised.  
4.3.4 has been revised.  
7.2 has been revised.  
7.8.1 has been revised.  
7.8.1.1 has been revised.  
7.8.1.3 has been revised.  
7.8.2 has been revised.  
7.8.7 has been revised.  
7.8.8 has been revised.  
7.9.1.2 has been revised.  
8.1.11.8 has been revised.  
8.2.2 has been revised.  
Appendix 16 has been revised.

**LIST OF REVISION PAGES**

<b>Page Number</b>	<b>Rev No</b>	<b>Revision Date</b>
GOM – 1 to GOM – 256	Rev 45	23 Mar 2026

**DISTRIBUTION LIST**

Location	Digital Copy	Hard Copy
Turkish DGCA	No	No
Library (original)	Yes	No
<a href="https://handling.corendonairlines.com">https://handling.corendonairlines.com</a> *	Yes	No
Accountable Manager	Yes	No
Chief Operating Officer	Yes	No
Ground Operations Department	Yes	No
Chief Flight Operations Officer	Yes	No
Training Manager	Yes	No
SMS Manager	Yes	No
Chief Compliance Monitoring Officer	Yes	No
Flight Operations Engineer	Yes	No
Complaints Management Department	Yes	No
Cabin Crew Department	Yes	No
All Aircraft	Yes	No

This document is available via library on Company network. For more information, consult Documentation Department.

\* Ground Handling Companies including catering and fuel service providers shall have the current version of Corendon Airlines Documents, Manuals, safety memos and bulletin etc. in usable format at each location where our operations are conducted and distribute the documents with their relevant handling staff internally. Quick Reference & GOM & Cargo Handling Manual & AHM 560, safety memos and bulletins... etc. shall be downloaded from Corendon Airlines web page address (<https://handling.corendonairlines.com/>) as soon as they are informed about the new revision. It is CAI responsibility to add these documents to the system within 2 days. Password will be given by Corendon Airlines Ground operation Department separately. ([groundoperation@corendon-airlines.com](mailto:groundoperation@corendon-airlines.com))

When a third party does not download the documents via <https://handling.corendonairlines.com> within 4 working days, a reminder e-mail should be sent the related parties day by day till the third party download the document.

Upon issuance of any document or revision, the Compliance Monitoring Supervisor shall create a recurring reminder in Outlook for follow-up purposes. This reminder will be scheduled 15 calendar days after distribution to ensure receipt and acknowledgment from all handling suppliers, and will remain active until documented confirmation has been obtained from each supplier.

At the end, if the third party still does not download the document within 4 weeks, Chief Operating Officer will review the contract and decide whether working with this company or not. The decision will be sent the third party with requesting corrective action.

## SYSTEM OF AMENDMENT AND REVISIONS

This document has been prepared in coordination with the departments of concern, reviewed by Chief Compliance Monitoring Officer, approved internally by Accountable Manager.

The page number, revision date and number are included in the header of each page. "Intentionally Left Blank" statement is printed on each blank page except for the cover page.

This document may be amended by two means;

- i. By the directives from Accountable Manager or Turkish DGCA and as a result of regulatory changes or,
- ii. By request/need of concerned parties, following the steps below:
  - Any manual user may propose an amendment to Quality Department by any means.
  - Ground Operation Department prepares amendment draft.
  - Quality Department reviews the amendment draft and ensures that it is coordinated with all the departments to be affected due to the revision.
  - Amendment draft is presented to the Accountable Manager for approval.

This document becomes effective after Accountable Manager approval.

When an amendment is approved by Accountable Manager, Documentation Department;

- Replaces the digital copies of the document on the both servers at Company Headquarters and Airport Facilities,
- Publishes the current revision on the digital library,
- Prints and distributes controlled copies of document to the addresses listed on Distribution List.

Holders of the document are responsible to insert amended pages in the document and record it to the revision page as soon as practicable.

Amendments must include the following information, if applicable:

- Revision date and number
- Numbers of the pages to be replaced with the new ones
- Numbers of the pages to be removed
- Numbers of the pages to be added

Quality Management is responsible for giving the decision whether a change is minor or major revision. Minor revisions are identified via following criteria:

- If the revision is in format of the document only (changes in paper size, font, company logo, etc.),
- If the revision is for error correction (correction of typing errors, clarification of misunderstandings, etc.),
- If the revision is only informative and does not affect any approved procedures, capabilities or privileges of the company (added explanations, pictures, updated graphs, etc.),
- Handwritten amendments are permitted only in situations requiring immediate action in the interest of safety with approval of related nominated persons, Chief Compliance Monitoring Officer and/or SMS Manager.

This document will be reviewed by Ground Operation Supervisors at least annually.



# GROUND OPERATION MANUAL

Doc Code: CA-GOP-GOM

Rev No: 45

Rev Date: 01 APR 2026

Page: 10

## Page Layout and Numbering System: Header



# GROUND OPERATION MANUAL

Doc Code: CA-GOP-GOM

Rev. No: 36

Rev. Date: 16 JUN 2023

Page: 9



Company Logo



Manual Name



Document Code,  
Revision Number

Date,  
Page Number

and

## Page Numbering:

This manual uses a standard page numbering system. Example page number is as below:

Doc Code: CA-GOP-GOM
Rev. No: 36
Rev. Date: 16 JUN 2023
Page: 9

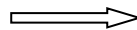

Page Number

## Table of Contents:

In the Table of Contents, the heading level is limited with Level 3.

### Example Table of Contents:

#### TABLE OF CONTENTS

<b>2. OPERATIONAL CONTROL AND SUPERVISION .....</b>	<b>2</b>
<b>2.1 SUPERVISION OF THE OPERATION BY CORENDON AIRLINES .....</b>	<b>2</b>
2.1.1 License and Qualification Validity .....	2
2.1.2 Competence of Operations Personnel.....	2
2.1.3 Control, Analysis and Storage of Records, Flight Documents and Data .....	3

Heading Level

Page Number

**List of Revision Pages:****LIST OF REVISION PAGES**

Page Number	Rev No	Revision Date
GOM – 1 to GOM – 232	Rev 39	01.04.2024

Each page numbers in the document are always revised after each publishment. For the details, please refer to Revision Highlights.

**Overview of Documents:**

Even the document has no revision; the Ground Operation Manual and other Ground Operations documents should be overviewed each year. If the document is not up to date and needs revision, the steps for revision described above will be followed.

**Monitoring of Documents in use:**

For monitoring of documents in use, the Documentation Department shall perform product audits and verify:

- Documents are available at the distributed location,
- Physically in good condition,
- Legible,
- Complete,
- Easily accessible,
- Up to date,
- Digital library is update

**Note:** Chief Operating Officer is also responsible of monitoring the documents for their own use and informs the Documentation Department about any issue concerning the items listed above.

**INTRODUCTION**

Ground Operations Manual has been prepared under the scope of Corendon Airlines Operations Manual Part A. No part of this manual or its extracts may be reproduced in any form, by print, photo print, microfilm or any other means, without written permission from Chief Operating Officer.

Also, this manual has been prepared in accordance with the conditions contained in the Corendon Airlines Air Operator Certificate (AOC), the relevant provisions of SHT-OPS and AIR-OPS Commercial Air Transport, IOSA Standards, IGOM Requirements and other applicable regulations, laws and rules. It reflects the current operational policies, regulations and procedures of Corendon Airlines.

All operations personnel shall be familiar with and comply with the laws, regulations, standards and procedures of the states in which operations are conducted, the conditions contained in the Corendon Airlines Air Operator Certificate (AOC) and with those contents of this manual which are relevant to the performance of their duties.

**The Content of AOC:**

The AOC is issued by the Turkish DGCA and it authorizes the conduct of commercial air transport operations in accordance with specified conditions and limitations. The AOC includes:

- i) Operator identification (name and location);
- ii) Date of issue and period of validity;
- iii) Description of types of operations authorized;
- iv) Type(s) of aircraft authorized for use;
- v) Authorized areas of operation or routes;
- vi) Exemptions, deviations and waivers;
- vii) Special authorizations, to include, as applicable:
  - a) Low visibility takeoff (LVTO);
  - b) CAT II and/or III approaches;
  - c) HGS (Head-up Guidance System) operations;
  - d) GPS approaches;
  - e) RVSM operations;
  - f) MNPS operations;
  - g) RNAV/RNP operations;
  - h) Transportation of dangerous goods;
  - i) Electronic Flight Bag (EFB) operations.

### **APPLICABILITY OF THE GOM**

Every flight shall be conducted in accordance with the provisions of;

- Corendon Airlines regulations and directives,
- Corendon Airlines OM Part A, B, C, D and GOM.
- Other Corendon Airlines approved/published/distributed relevant documents and manuals.

When the documentation listed above contradicts any rules or regulations established and mandated by State Authorities, the more restrictive shall be applicable until revisions can be implemented in the appropriate documentation. Any discrepancies noted shall be reported to the Ground Operations Department.

The Handling Agents and its staff should supervise and coordinate Corendon Airlines airside operations in accordance with this manual and the written procedures in related chapters.

Duties and responsibility of supervision of ground handling activities are laid down in the contract with a separate agent for supervision or are part of the contract with the handling agent (SGHA according to IATA AHM).

In general areas of supervision are:

- Administration functions
- Representation
- Coordination functions
- Passenger service
- Aircraft servicing
- Catering and catering supplies
- Load control
- Aircraft on- and offloading
- Cargo warehouse handling
- Communication
- Safety and security
- Emergency
- De/Anti-icing
- Aircraft ground movement
- Aircraft handling

It is Corendon Airlines' policy that standards and procedures outlined in the GOM shall be adhered to at all times. In the event of willful or negligent disobedience to those rules and regulations set out within this manual, the personnel concerned may become subject to disciplinary, legal or penalty action. However, nothing contained in the GOM shall prevent personnel from exercising their own best judgment in cases of emergency or during any irregularity for which the GOM gives no guidance.

Corendon Airlines ground operations management system is described in this manual in details and we ensure control of ground handling operations and the management of safety and security outcomes by this document and other referred company manuals / materials such as Safety Management System Manual, Security Manual, and Emergency Response Plan etc...

The manual has been prepared, reviewed and approved internally by Corendon Airlines personnel as shown on the Approval Page.

To ensure that the provisions of the GOM are fully understood and applied by all related operational personnel, whether in the aircraft or between the flight crew and ground crew during line operations,

during training and evaluation activities, **the common language to be used is English.** English knowledge is an essential employment criterion for related personnel.

This manual is published in Company Intranet in the **digital library** which can be accessed remotely by personnel via intranet and it is available for all related staff at any time.

## TERMS AND DEFINITIONS

**AGENT-HANDLING-** Company Representative Handling Company

**AGENT-RAMP-** A person who supervises and co-ordinates on the ramp the tasks of ground handling for an aircraft departure or arrival

**AIRPORT-ALTERNATE-** Planned alternative en route and destination airport(s) for a flight

**AIRPORT DEPARTURE-** The airport from which the aircraft last departed, using the same Flight Number

**AIRPORT DESTINATION-** Ultimate intended terminating airport of a flight

**AIR WAYBILL-** The document entitled "Air Waybill/Air Consignment Note" made out by or behalf of the shipper which evidences the contract between the shipper and carrier(s) for carriage of the goods over routes of the carrier(s)

**ALLOWED TRAFFIC LOADS-** The load which can be carried on the aircraft on any one sector and its difference between the allowed weight for take-off and the operating weight

**BAGGAGE-** Which is the equivalent to the term "Luggage" such articles, effects, and other personnel property of a passenger as are necessary or appropriate for wear, use, comfort, or convenience in connection with his trip. Unless otherwise specified, it includes both checked and unchecked baggage

**BALLAST-** Dead load weight carried to achieve a particular balance condition

**BASIC IND-** EX A numerical expression of the center of gravity of the aircraft at its basic weights

**BOARDING-** Equivalent to term "Embarkation" means passengers entering an aircraft

**BULK-** Loading piece by piece

**CABIN-** A compartment where passengers' seats are installed

**CARGO-** Any goods carried on the aircraft which are covered by an air waybill

**CENTRE OF GRAVITY-** (C of G) C of G of an aircraft is the point at which its total weight may be considered to act as concentrated force

**COCKPIT-** That part of an aircraft from which the crew control the aircraft

**CREW-CABIN-** Person performing duties on the flight other than the cockpit

**DANGEROUS GOODS-** Articles or substances which are capable of posing a significant risk to health, safety or property when transported by air and which are classified as such in the IATA Dangerous Goods Regulations

**FLIGHT-** The operation of an aircraft between two or more points

**FLIGHT NUMBER-** The alpha-numerical designator of a flight prefixed by a two-letter or three-character designator

**FUEL-TAKE OFF-** The amount of fuel on board less the fuel consumed before the take-off run

**FUEL-TRIP-** The amount of fuel planned to be consumed from take-off to the station of first intended landing

**GALLEY-** The integral part of aircraft where pantry/catering material is stored

**GENERAL DECLARATION-** A standard document giving certain details about a flight required for aircraft clearance by government authorities' countries

**INDEX UNIT-** An expression of moment, i.e. weight x lever arm caused by weight added to the aircraft, in order to establish the C of G

**LOAD-** Any item carried in an aircraft other than is included in the basic operating weight

**LOAD PLANNING-** A part of load control

**LOADING INSTRUCTION-** Instructions given by Load Control to the person responsible for the aircraft loading.

**LOAD SHEET-** Completed load sheet contains all weight data pertaining to a particular flight, i.e. the weight of the aircraft crew, pantry, fuel, passengers, baggage, cargo and mail. It also contains where necessary details of the distribution of this load in the aircraft

**MAIL-** Goods carried under the terms of an international postal convention

**MANIFEST-CARGO-** A traffic document listing the details of the cargo to be carried on a flight

**MANIFEST-PASSENGER-** A traffic document listing the details of names of passengers to be carried on a flight

**MESSAGE-** Where quoted it is assumed that the fastest possible means of sending a message will be used. This refers to SITA, telex or data link

**MOVEMENT-** The arrival or departure of an aircraft

**Next of Kin (NOK) -** Person's closest living blood relative or relatives

**ONE-OFF FLIGHTS -** Corendon Airlines does not perform domestic flights except one-off flights

**PAY LOAD-** The weight of passengers, baggage, cargo and mail and includes both revenue and non-revenue items

**REGISTRATION AIRCRAFT-** A unique alpha-numeric designation for an aircraft

**SEATING-** The procedure whereby passengers obtain their seats—it may be free, allocated or selected

**SPECIAL LOAD-** A load which, owing to its nature or value requires special attention and treatment during the process of acceptance, storage, transportation, loading and unloading

**STATION-** The equivalent to the Term "Airport"

**TRAFFIC-** The activity of transportation of passengers, baggage, cargo, and mail

**TRANSFER-** Traffic which arrives on a flight and continues on another flight of the same airline or another airline within a defined time limit

**TRANSFER HOLD BAGGAGE-** Corendon Airlines does not operate any transfer flights

**UNDERLOAD-** The difference between the allowed traffic load and subsequently loaded as a unit into aircraft

**WEIGHT-CATERING-** Equipment and supplies for in flight distribution to the passengers and crew

**WEIGHT-DRY OPERATING-** The Basic Weights plus "Operational items" e.g. crew, crew baggage, flight equipment and pantry as per company specification and is equal to "Operational Empty Weight"

**WEIGHT-LANDING-** Takeoff weight minus trip fuel

**WEIGHT-MAXIMUM ZERO FUEL WEIGHT-** The weight limit imposed beyond which an increase in load must consist entirely of usable fuel and any other consumable fuel, e.g. injection water

**WEIGHT-TAKE OFF-** Zero fuel weights plus take-off fuel

**WEIGHT-ZERO FUEL-** Total traffic load plus the dry operating weight

**ABBREVIATIONS**

<b>AA</b>	<b>Actual arrival</b>	<b>PIC</b>	<b>Pilot-in-Command</b>
<b>A/C</b>	<b>Aircraft</b>	<b>PIR</b>	<b>Property Irregularity Report</b>
<b>AD</b>	<b>Actual Departure</b>	<b>PSM</b>	<b>Passenger Service Message</b>
<b>AMS</b>	<b>Amsterdam (Schiphol) Airport</b>	<b>PTM</b>	<b>Passenger Transfer Message</b>
<b>AOG</b>	<b>Aircraft on Ground</b>	<b>PX</b>	<b>Passenger Identifier</b>
<b>APU</b>	<b>Auxiliary Power Unit</b>	<b>RCM</b>	<b>Corrosive</b>
<b>ASU</b>	<b>Air starter unit</b>	<b>RMD</b>	<b>Miscellaneous Dangerous Goods</b>
<b>ATA/D</b>	<b>Actual Time of Arrival/Departure</b>	<b>RIS</b>	<b>Infectious Substance</b>
<b>ATC</b>	<b>Air Traffic Control</b>	<b>RFG</b>	<b>Flammable Compressed Gas</b>
<b>AWB</b>	<b>Air Waybill</b>	<b>RFL</b>	<b>Flammable Liquid</b>
<b>AVIH</b>	<b>Live Animals</b>	<b>RFS</b>	<b>Flammable Solid</b>
<b>BED</b>	<b>Stretcher installed</b>	<b>RFW</b>	<b>Dangerous when Wet</b>
<b>C</b>	<b>Cargo</b>	<b>REX</b>	<b>Normally Forbidden</b>
<b>CAA</b>	<b>Civil Aviation Authority</b>	<b>ROP</b>	<b>Organic Peroxide</b>
<b>CIS</b>	<b>Cabin Information Sheet</b>	<b>ROX</b>	<b>Oxidizer</b>
<b>CPT</b>	<b>Compartment</b>	<b>RPG</b>	<b>Toxic gas</b>
<b>CTOT</b>	<b>Calculated Takeoff Time</b>	<b>STA</b>	<b>Scheduled Time of Arrival</b>
<b>DCS</b>	<b>Departure Control System</b>	<b>SEC</b>	<b>Security Bag</b>
<b>DOI</b>	<b>Dry Operating Index</b>	<b>SI</b>	<b>Supplementary Information</b>
<b>DOW</b>	<b>Dry Operating Weight</b>	<b>SOM</b>	<b>Seat Occupied Message</b>
<b>EA</b>	<b>Estimated Time of Arrival</b>	<b>STRC</b>	<b>Stretcher</b>
<b>ED</b>	<b>Estimated time of Departure</b>	<b>SSR</b>	<b>Special Service Request</b>
<b>EDP</b>	<b>Electronic Data Process</b>	<b>RPB</b>	<b>Toxic</b>
<b>EASA</b>	<b>European Aviation Safety Agency</b>	<b>STD</b>	<b>Scheduled Time of Departure</b>
<b>EIC</b>	<b>Equipment in Compartment</b>	<b>TOW</b>	<b>Take Off Weight</b>
<b>ETD</b>	<b>Estimated Time of Departure</b>	<b>UCM</b>	<b>ULD Control Message</b>
<b>FWD</b>	<b>Forward</b>	<b>TPM</b>	<b>Teletype Passenger Manifest</b>
<b>GOM</b>	<b>Ground Operation Manual</b>	<b>UG US</b>	<b>Gallon</b>
<b>GPU</b>	<b>Ground Power Unit</b>	<b>ULD</b>	<b>Unit Load Device</b>
<b>HEA</b>	<b>Heavy Cargo</b>	<b>UM</b>	<b>Unaccompanied Minor</b>
<b>HUM</b>	<b>Human Remains in Coffin</b>	<b>X</b>	<b>No facility Seat</b>
<b>HIR</b>	<b>Handling Irregularity Report</b>	<b>Y</b>	<b>Economy Class</b>
<b>IATA</b>	<b>International Air Transportation Association</b>	<b>ZFW</b>	<b>Zero Fuel Weight</b>
<b>ICAO</b>	<b>International Civil Aviation Organization</b>	<b>WET</b>	<b>Wet Cargo</b>
<b>ICE</b>	<b>Dry ice</b>		
<b>IGOM</b>	<b>IATA Ground Operations Manual</b>		
<b>INAD</b>	<b>Inadmissible Passenger</b>		
<b>LDM</b>	<b>Load Message</b>		
<b>LIR</b>	<b>Loading Instruction Report</b>		
<b>LMC</b>	<b>Last Minute Change</b>		
<b>LT</b>	<b>Liter</b>		
<b>MSG</b>	<b>Message</b>		
<b>MVT</b>	<b>Movement</b>		
<b>OM</b>	<b>Operation Manual</b>		
<b>PAX</b>	<b>Passenger Identifier</b>		
<b>PER</b>	<b>Perishable Cargo</b>		
<b>MAX</b>	<b>Maximum</b>		

**TABLE OF CONTENTS**

**APPROVAL PAGE ..... 1**

**RECORD OF REVISIONS PAGE ..... 3**

**REVISION HIGHLIGHTS ..... 6**

**LIST OF REVISION PAGES ..... 7**

**DISTRIBUTION LIST ..... 8**

**SYSTEM OF AMENDMENT AND REVISIONS ..... 9**

**INTRODUCTION ..... 12**

**APPLICABILITY OF THE GOM ..... 13**

**TERMS AND DEFINITIONS ..... 14**

**ABBREVIATIONS ..... 16**

**1. RESPONSIBILITIES AND DUTIES ..... 23**

**1.1 ORGANIZATION CHARTS & CONTACTS ..... 23**

1.1.1 *Company Organizational Structure:* ..... 23

1.1.2 *Ground Operations Department Organization Chart:* ..... 24

1.1.3 *Contact Information:* ..... 25

**1.2 CORPORATE COMMITMENT BY THE ACCOUNTABLE MANAGER ..... 26**

**1.3 JOB DESCRIPTIONS ..... 27**

**1.4 FLIGHT NUMBERS & CODES ..... 27**

**1.5 TRAINING ..... 27**

1.5.1 *General* ..... 27

1.5.2 *Minimum Content of Training* ..... 28

1.5.3 *Syllabus* ..... 29

1.5.4 *Ground Operation Department Initial Training Program* ..... 36

1.5.5 *Ground Operation Department Recurrent Training Program* ..... 37

1.5.6 *Pass Standards* ..... 38

1.5.7 *Familiarization of Agencies* ..... 38

1.5.8 *Training in case of Job Interruption* ..... 39

1.5.9 *Ground Operations Instructor* ..... 39

1.5.10 *Ground Operation Inspector* ..... 40

**1.6 COMPLIANCE MONITORING PROGRAM ..... 41**

**1.7 Supplier Selection ..... 41**

**1.8 Supplier Evaluation ..... 42**

**2 PASSENGER & BAGGAGE HANDLING PROCEDURES ..... 43**

**2.1 PASSENGER DEPARTURE & CHECK-IN PROCESS ..... 43**

2.1.1 *Flight Information Boards* ..... 43

2.1.2 *Passenger Pre-Flight Preparation* ..... 43

2.1.3 *Opening of Check-In Counters* ..... 43

2.1.4 *Check in Procedure-General* ..... 44

2.1.5 *Boarding Procedure-General* ..... 46

**2.2 Passenger Arrival and Transit ..... 48**

2.2.1 *Pre-Arrival* ..... 48

2.2.2 *Arrival* ..... 48

2.2.3 *Transit Passenger* ..... 48

2.2.4 *Programmed Aircraft Change Route* ..... 49

**2.3 SPECIAL CATEGORIES OF PASSENGERS ..... 49**

2.3.1 *Passenger with Reduced Mobility (PRM)* ..... 50

2.3.2. Passengers on Stretchers (STCR) .....	51
2.3.3. Expectant Mother (Pregnant Passengers).....	52
2.3.4. Unaccompanied Minors (UMNR) and Young Passengers (YPNR) .....	53
2.3.5. Infants and Children .....	53
2.3.6 Maximum SCP numbers on B737/800/8.....	56
<b>2.4 PASSENGER SECURITY .....</b>	<b>56</b>
2.4.1. Security of Documents.....	56
2.4.2. Potentially Threatening Passengers .....	57
2.4.3. Procedures for Unruly Passengers.....	63
2.4.4. Acceptance of liquids in cabin .....	64
<b>2.5 PASSENGER IRREGULARITIES .....</b>	<b>65</b>
2.5.1. Information to Passenger.....	65
2.5.2. Services provided to passengers in case of Delays, Cancellations and Other Irregularities .....	66
2.5.3. Sick, unacceptable or Handicapped Passenger .....	67
2.5.4 Passengers Not Requiring a Medical Clearance .....	68
2.5.5 Plaster Cast .....	68
<b>2.6 BAGGAGE HANDLING PROCEDURES.....</b>	<b>68</b>
2.6.1. Cabin Baggage .....	68
2.6.2. Checked Baggage .....	70
2.6.3. Special Baggage's.....	71
<b>2.7 BAGGAGE SECURITY.....</b>	<b>77</b>
<b>2.8 BAGGAGE IRREGULARITIES .....</b>	<b>79</b>
2.8.1. General Baggage Irregularity Instructions and Limits of Liability .....	80
2.8.2. Property Irregularity Report (PIR) .....	80
2.8.3. Distribution of PIR .....	80
2.8.4. Damaged baggage.....	80
2.8.5. Missing baggage .....	81
2.8.6. Rush baggage.....	81
2.8.7. Found Items on Board .....	81
<b>2.9 BAGGAGE ROOM/SORTING AREA PREPARATION .....</b>	<b>81</b>
2.9.1 General.....	81
2.9.2 Baggage Tags/Sorting.....	81
2.9.3 Baggage Cut-Off and Verification Process .....	81
2.9.4 Baggage Reconciliation.....	81
<b>3. AIRCRAFT &amp; RAMP HANDLING .....</b>	<b>82</b>
<b>3.1. RAMP SAFETY IN AIRCRAFT HANDLING .....</b>	<b>82</b>
3.1.1. General Ramp Safety.....	83
3.1.2. FOD–Foreign Object Debris .....	85
3.1.3. General Safety Instructions for Ground Support Equipment (GSE) .....	85
3.1.4 Ground Support Equipment Safety Driving and Parking inside ERA.....	89
3.1.5 Fire.....	90
<b>3.2. POTABLE WATER SERVICING .....</b>	<b>90</b>
3.2.1. Filling the potable-water tank.....	91
3.2.2. Potable Water Units Servicing Procedure .....	91
3.2.3. Water Servicing During Freezing Conditions .....	91
<b>3.3. TOILET SERVICING .....</b>	<b>92</b>
3.3.1. Toilet Servicing Procedure .....	92
3.3.2. Servicing During Freezing Conditions .....	93
<b>3.4. SAFETY DURING FUELLING/DEFUELLING.....</b>	<b>93</b>
3.4.1. Fueling Safety Zone .....	93
3.4.2. Fuel Spillage / In the event of a fire.....	94
3.4.3. Refueling/Defueling with Passengers or crew embarking, on board or disembarking the aircraft: .....	95
<b>3.5. CATERING OPERATING PROCEDURES .....</b>	<b>96</b>
<b>3.6. ADVERSE WEATHER CONDITIONS.....</b>	<b>97</b>
3.6.1 Winter or Slippery Apron Conditions .....	97
3.6.2. Thunderstorms .....	97

3.6.3. High Wind Conditions.....	97
3.6.4 Storms-Lightning .....	98
3.6.5 Sandstorms and Low Visibility.....	98
3.6.6 Intense Heat .....	99
<b>3.7. SAFETY CONES .....</b>	<b>99</b>
3.7.1. Safety Cone Placement and Removal.....	99
<b>3.8. AIRCRAFT CHOCKING.....</b>	<b>99</b>
3.8.1. Wheel Chock Placement.....	99
<b>3.9. HAND SIGNALS .....</b>	<b>100</b>
3.9.1. Conditions for Using Hand Signals .....	100
3.9.2. Guide Person Hand Signals (For Ground Service Equipments) .....	101
3.9.3. Marshalling Hand Signals (For Aircraft) .....	101
3.9.4. Technical/Servicing Hand Signals–Ground Staff to Flight Crew .....	101
3.9.5. Technical/Servicing Hand Signals–Flight Crew to Ground Staff.....	101
3.9.6. Aircraft Movement Hand Signals–Headset Operator to Tug Driver.....	101
3.9.7. Aircraft Movement Hand Signals–Wingwalker to Headset Operator/Tug Driver.....	101
<b>3.10. AIRCRAFT ARRIVAL .....</b>	<b>101</b>
3.10.1. Actions Prior to Arrival .....	101
3.10.2. Standard Arrival Procedure .....	102
3.10.3. Actions after Arrival .....	102
3.10.4. Turnaround Timeline and Phase Management.....	103
<b>3.11. AIRCRAFT DOORS .....</b>	<b>105</b>
3.11.1. Cabin Access Doors.....	105
3.11.2. Cargo Hold Doors .....	106
<b>3.12. AIRCRAFT LOADING .....</b>	<b>107</b>
3.12.1. Supervision of Aircraft Loading .....	107
3.12.2. Safety Requirements Specific to Aircraft Loading Operations.....	108
3.12.3. General Loading Precautions .....	109
3.12.4. Spills in Cargo Holds .....	109
3.12.5. Cargo Hold Inspection .....	109
3.12.6. Compartment Separator Nets .....	109
3.12.7. Aircraft Ground Stability .....	110
3.12.8. Offloading Procedure .....	110
3.12.9. Loading Procedure .....	111
<b>3.13. AIRCRAFT DEPARTURE.....</b>	<b>113</b>
3.13.1. Wheel Chock Removal.....	113
3.13.2. Action Prior to Departure .....	114
3.13.3. Pre-Departure Table.....	115
3.13.4. Pre-Departure Check .....	115
3.13.5. Communication Requirements.....	116
3.13.6. Preparation for Pushback.....	117
3.13.7. Pushback & Pull Forward .....	118
3.13.8. Wingwalker .....	124
3.13.9. Open Ramp Departure .....	125
3.13.10. Maneuvering during Adverse Weather Conditions .....	125
3.13.11. Icy Conditions .....	125
3.13.12. Nose Gear Steering.....	126
3.13.13. Anti-Collision Lights.....	126
3.13.14. Engine Cross Bleed Start.....	126
3.13.15. Re-Establishing Communication after Departure.....	126
3.13.16. Interphone Communication Failure.....	127
<b>3.14. AIRCRAFT TOWING .....</b>	<b>127</b>
3.14.1. Aircraft Towing Requirements .....	127
3.14.2. Towing Maneuvering .....	127
3.14.3. Towing Preparation.....	128
3.14.4. Towing Completion .....	128
3.14.5. Incidents during Towing .....	128

3.14.6. Towing Limits .....	128
3.14.7 Long Term Parking for Aircraft.....	128
<b>3.15. AIRCRAFT DE/ANTI ICING .....</b>	<b>129</b>
3.15.1. Procedures.....	129
3.15.2. Precautions for de-icing / anti-icing .....	129
3.15.3. Fluid application .....	130
3.15.4. Post De-Icing/Anti-Icing Check .....	130
3.15.5. No De-Icing / Anti-Icing Fluid Available.....	130
3.15.6. De-icing Fluids and holdover time tables .....	130
3.15.7. Responsibilities regarding de-icing / anti-icing .....	130
3.15.8. Company Inspecting .....	131
3.15.9. Approved Fluids.....	131
3.15.10 Staff Training and Qualification .....	132
<b>3.16. AIRCRAFT CLEANING.....</b>	<b>133</b>
3.16.1 General.....	133
3.16.2 Cleaning Equipment .....	134
3.16.3 Health and Safety General Instructions.....	134
3.16.4 Lost/Found/Damage/Suspicious Items .....	135
3.16.5 Garbage Disposal .....	135
<b>3.17 Protection of Aircraft.....</b>	<b>135</b>
3.17.1 Aircraft Sealing.....	137
<b>4. LOAD CONTROL AND COMMUNICATION SYSTEM .....</b>	<b>138</b>
<b>4.1 WEIGHT AND BALANCE DOCUMENTATION .....</b>	<b>138</b>
4.1.1. Preparation of a Loading Instruction .....	138
4.1.2. Load & Trim Sheet Preparation .....	138
4.1.3. Applicable Weights for Passengers, Baggage and Crew .....	139
4.1.4. Passenger Distribution .....	140
4.1.4.1. Seating Policy/Procedures.....	140
4.1.5. Example of a Manual Corendon Airlines Load Trim Sheet .....	141
<b>4.2 USE OF LOAD AND TRIM SHEET .....</b>	<b>141</b>
4.2.1. List of Corendon Airlines Aircraft and Applicable L/T Sheets.....	141
4.2.2. Last Minute Changes.....	141
4.2.3. Abbreviations Used in Regard with Load and Trim Sheet .....	142
<b>4.3 COMMUNICATION SYSTEM .....</b>	<b>143</b>
4.3.1. Flight Movement Messages .....	143
4.3.2. Delay Messages.....	144
4.3.3. Example of MVT-Message.....	144
4.3.4. Delay Codes.....	144
<b>4.4. OTHER MESSAGE FOR LOAD CONTROL AND INFORMATION .....</b>	<b>144</b>
4.4.1. Load Message (LDM).....	144
4.4.2. On Board Message (O/B) .....	145
4.4.3. Passenger Transfer Message (PTM).....	145
4.4.4. Passenger Service Message (PSM) .....	145
4.4.5. Tele Type Passenger Manifest.....	146
4.4.6. Seat Occupied Message .....	146
4.4.7. Ad-hoc Schedule Message (ASM) And Flight Disposition Message (FD) .....	146
<b>5. CARGO HANDLING .....</b>	<b>149</b>
<b>5.1. GENERAL .....</b>	<b>149</b>
<b>5.2. ACCEPTANCE OF CARRIAGE OF CARGO .....</b>	<b>149</b>
<b>5.3. DANGEROUS GOODS .....</b>	<b>149</b>
<b>5.4. LIVE ANIMALS.....</b>	<b>149</b>
<b>5.5. OTHER SPECIAL CARGO .....</b>	<b>149</b>
5.5.1 Outsized Cargo and Heavy Cargo .....	149
5.5.2 Live animal.....	150

5.5.3 Perishables.....	151
<b>5.6. COMPANY MAIL AND COMPANY MATERIAL (CO-MAIL &amp; CO-MAT).....</b>	<b>154</b>
<b>5.7. RESPONSIBILITIES.....</b>	<b>154</b>
<b>6. AIRCRAFT DATA-QUICK REFERENCE.....</b>	<b>155</b>
<b>6.1. AIRCRAFT DIMENSIONS.....</b>	<b>155</b>
6.1.1. <i>Baggage / Cargo Compartment Volumes.....</i>	<i>157</i>
6.1.2. <i>Cargo Door Dimensions.....</i>	<i>158</i>
<b>6.2 AIRCRAFT SERVICING ARRANGEMENTS.....</b>	<b>160</b>
<b>6.2. AIRCRAFT GALLEY PLANS.....</b>	<b>162</b>
<b>7. SECURITY AND ACCIDENT PROCEDURE.....</b>	<b>163</b>
7.1. SECURITY PROCEDURES.....	163
7.2. FIRE AND FIRE FIGHTING.....	163
7.3. AIRCRAFT ACCIDENT PROCEDURE.....	164
7.3.1 Emergencies Requiring the Evacuation of an Aircraft during Ground Handling.....	164
<b>TYPE OF EMERGENCIES.....</b>	<b>164</b>
<b>AIRCRAFT FIRE.....</b>	<b>165</b>
<b>DANGEROUS GOODS INCIDENT.....</b>	<b>165</b>
<b>SECURITY INCIDENT.....</b>	<b>165</b>
<b>GENERAL ITEMS TO CONSIDER.....</b>	<b>165</b>
<b>AIRCRAFT EVACUATION WITHOUT FLIGHT CREW AND PASSENGERS ON BOARD.....</b>	<b>166</b>
<b>RECOGNIZING AN EMERGENCY.....</b>	<b>166</b>
<b>EMERGENCY NOTIFICATION.....</b>	<b>166</b>
<b>AIRCRAFT EVACUATION.....</b>	<b>166</b>
<b>SECURING THE AIRCRAFT.....</b>	<b>166</b>
<b>REPORTING.....</b>	<b>167</b>
7.4. ACCIDENTS / INCIDENTS.....	167
7.5. RAMP INCIDENT/ACCIDENT REPORT.....	167
7.6. DEATH ON BOARD.....	167
7.7. CHILD BIRTH DURING THE FLIGHT.....	168
7.8. SAFETY MANAGEMENT SYSTEM (SMS).....	168
7.8.1. <i>Responsibilities.....</i>	<i>168</i>
7.8.2. <i>Safety Risk Management.....</i>	<i>170</i>
7.8.3. <i>Reporting and Investigation.....</i>	<i>171</i>
7.8.4. <i>Management of Change (MoC).....</i>	<i>172</i>
7.8.5. <i>SERA Aerodromes Module.....</i>	<i>172</i>
7.8.6. <i>Safety Bulletins.....</i>	<i>172</i>
7.8.7. <i>Safety Performance Indicators (SPI's).....</i>	<i>172</i>
7.8.8. <i>Meetings.....</i>	<i>173</i>
7.8.9. <i>Trainings.....</i>	<i>173</i>
7.9. EMERGENCY RESPONSE PLAN (ERP).....	173
7.9.1. <i>Responsibilities.....</i>	<i>173</i>
7.9.2 <i>Crisis Document List.....</i>	<i>175</i>
7.10 REDUCTION OF CABIN CREW DURING GROUND OPERATIONS AND IN UNFORESEEN CIRCUMSTANCES.....	175
<b>8. DANGEROUS GOODS AND WEAPONS.....</b>	<b>176</b>
<b>8.1 THE TRANSPORT OF DANGEROUS GOODS.....</b>	<b>176</b>
8.1.1 <i>Terminology.....</i>	<i>176</i>
8.1.2 <i>General Guidance on the Transport of DG.....</i>	<i>178</i>

8.1.3 Corendon Airlines Policy on the Transport of DG .....	178
8.1.4 Operator's Responsibilities .....	179
8.1.5 Limitations on the Transport of DG .....	180
8.1.6 Acceptance of DG .....	180
8.1.7 Labeling and Marking of Dangerous Goods .....	183
8.1.8 Dangerous Goods Notification to Commander (NOTOC) .....	205
8.1.9 Loading and Stowage of Dangerous Goods .....	208
8.1.10 Training Programs .....	210
8.1.11 Emergency Situations .....	211
8.1.12 SEGREGATION, SEPARATION AND STOWAGE OF DANGEROUS GOODS .....	218
<b>8.2 CARRIAGE OF WEAPONS, AMMUNITION AND ELECTRONIC DEVICES .....</b>	<b>218</b>
8.2.1 Procedures for Carriage of Firearms and Weapons .....	218
8.2.2 Rules for Use of Portable Electronic Devices .....	222
<b>9. GOVERNMENT CLEARANCE REQUIREMENTS .....</b>	<b>224</b>
9.1. GENERAL .....	224
9.2. GENERAL DECLARATION .....	224
9.3. PASSENGER MANIFEST .....	224
9.4 CARGO MANIFEST .....	225
9.5. COUNTRY REGULATION .....	225
<b>10. COMPANY DOCUMENTS / FORMS .....</b>	<b>226</b>
APPENDIX-1 Form of Indemnity .....	228
APPENDIX-2 UM Form .....	229
APPENDIX-3 Property Irregularity Report: .....	230
APPENDIX-4 Co-Mail Delivery Form: .....	231
APPENDIX-5 Co-Mail / Co-Mat Forms: .....	232
APPENDIX-6 Handling Irregularity Report .....	233
APPENDIX-7 Baggage Irregularity Information Form: .....	234
APPENDIX-8 Seat Chart B737-800 / 737-800 MAX: .....	235
APPENDIX-9 General Declaration: .....	237
APPENDIX-10 Loading Instruction Report (All B738 Types) .....	238
APPENDIX-11 IATA DGR Table 2.3A .....	239
APPENDIX-12 Pre-Departure Table .....	241
APPENDIX-13 On the Job Training Form .....	243
APPENDIX-14 Weapon Delivery Form .....	247
APPENDIX-15 Weapon NOTOC Form .....	248
APPENDIX-16 Sample NOTOC form .....	249
APPENDIX-17 Passenger Irregularity Form .....	250
APPENDIX-18 Boarding Announcement .....	251
<b>11 AIR PASSENGER RIGHTS .....</b>	<b>252</b>
11.1 Check in and Boarding Procedure – General .....	252
11.2 Information to Passenger .....	252
11.3 HANDLING IRREGULARITIES AND SPECIALS .....	252
11.3.1 Information to passengers .....	252
11.4 SERVICES PROVIDED TO PASSENGERS IN CASE OF DENIED BOARDING (DBC) / FLIGHT CANCELLATION OR DELAY .....	253
11.4.1 Denied Boarding (DBC) .....	253
11.4.2. Cancellation of Flight .....	253
11.4.3 Delay .....	254
11.4.4. Payable and non-payable amounts in case of Denied Boarding (DBC) / Flight Cancellation and/or Delay .....	255
11.5 UPGRADING & DOWNGRADING .....	255

## 1. RESPONSIBILITIES AND DUTIES

### 1.1 ORGANIZATION CHARTS & CONTACTS

#### 1.1.1 Company Organizational Structure:

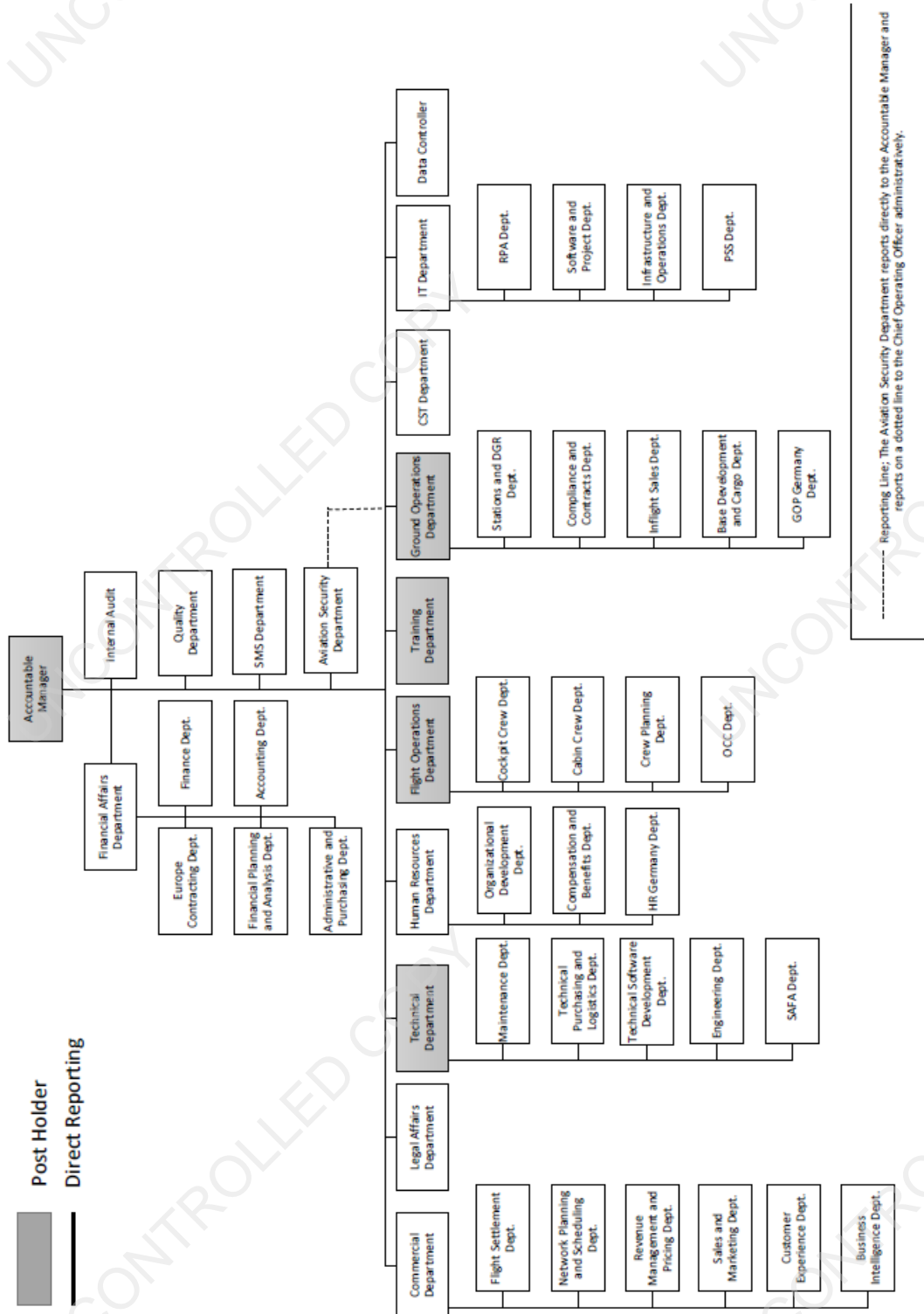

## 1.1.2 Ground Operations Department Organization Chart:

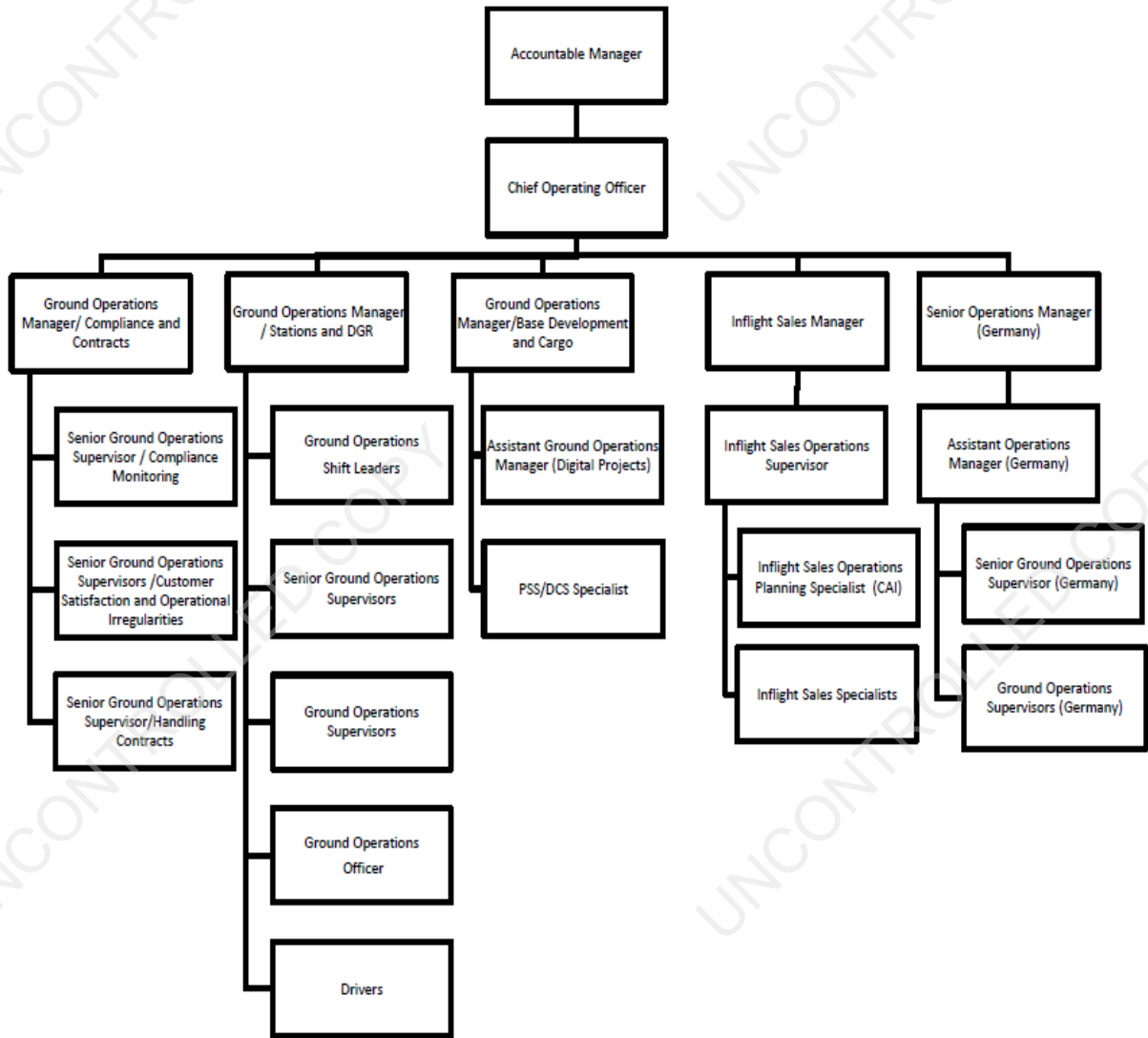

## 1.1.3 Contact Information:

<b>Headquarters:</b>	<b>CORENDON AIRLINES / TURİSTİK HAVA TAŞIMACILIK A.Ş.</b> Address: Güzeloluk Mah. 1879 Sok. No: 148 07200 Antalya / TURKEY Phone: + 90 242 323 34 00 pbx Fax: + 90 242 324 32 40 SITA: AYTDP7H, AYTDC7H, AYTCM7H
<b>Ground Operations:</b>	Atılay BATU (Chief Operating Officer)  <b>Phone:</b> + 90 242 330 34 36 pbx <b>Fax:</b> + 90 242 324 32 40 <b>Mobile 7/24:</b> +90 549 412 00 36 <b>SITA:</b> AYTDP7H <b>E-mail:</b> <a href="mailto:groundoperations@corendon-airlines.com">groundoperations@corendon-airlines.com</a>
<b>Sabiha Gökçen (SAW) Station</b>	SAW Station Supervisor <b>Phone :</b> +90 549 790 29 25 <b>E-mail :</b> <a href="mailto:saw@corendon-airlines.com">saw@corendon-airlines.com</a>
<b>Operations Control Center (OCC):</b>	Phone: +90 242 330 32 90 Fax: +90 242 330 35 22 SITA: AYTDC7H E-mail: <a href="mailto:occ@corendon-airlines.com">occ@corendon-airlines.com</a>
<b>Representative in Netherlands:</b>	Phone : + 31 629 43 39 09 Fax: + 31 20 659 27 40
<b>Representative in Belgium:</b>	Phone: +32 (0) 2 753 40 15 Fax: +32 (0) 2 753 40 16
<b>Representative in Germany:</b>	Phone : +49 174 178 9000

**Note:** We are open for your suggestions at any time. Please feel free to share your comments with us.

**1.2 CORPORATE COMMITMENT BY THE ACCOUNTABLE MANAGER**

We, undersign that Corendon Airlines Ground Operations Manual and its contents are in compliance with conditions contained in the Corendon Airlines Air Operator Certificate (AOC) and requirements of the Turkish DGCA, ICAO, EASA, IOSA, ISO and other relevant, applicable national and international regulations. The rules and procedures of Ground Operations Manual shall be adhered to by all related operational personnel.

It is accepted that these procedures do not override the necessity of complying with any new or amended regulation published by the Turkish DGCA from time to time where the new or amended regulations are in conflict with these procedures.

It is understood that the Turkish DGCA will approve this organization whilst the Turkish DGCA is satisfied that the procedures are being followed and work standards maintained. It is further understood that the Turkish DGCA reserves the right to suspend, limit or revoke the AOC approval of the organization if the Turkish DGCA has evidence that procedures are not followed or standards not upheld.

A handwritten signature in blue ink, appearing to read "Yıldıray KARAER".

**Yıldıray KARAER**  
**Accountable Manager**

For and on behalf of Corendon Airlines

### 1.3 JOB DESCRIPTIONS

Corendon Airlines ensures all ground operational positions are filled by personnel on the basis of knowledge, skills, training and experience appropriate for the positions. Employment criteria are specified under each Job Descriptions.

Chief Operating Officer is The Nominated Person for all ground operations activities, leads the ground operation management system and has the authority to take actions in respect of safe and secure operations.

All Management and Non-Management Personnel are informed regarding their job authorities and responsibilities by an announcement e-mail which is sent by SERA reporting system once in a year. In addition, the authorities and responsibilities are stated in Human Resources Employment Contract.

Please see Corendon Airlines Digital Library for all Job Descriptions which mentioned in Organization Chart in Chapter 1.1 of this manual. The authorities and responsibilities of management and non-management personnel that perform functions relevant to the safety and security of ground operations are defined in these job descriptions.

All Personnel are read only authorized with their password for access to Digital Library.

For continuity of supervision, in the absence of the nominated persons, please see the assignment list from the Corendon Airlines Digital Library. For the details of management continuity, please see Corporate Manual and Human Resources Manual.

### 1.4 FLIGHT NUMBERS & CODES

IATA Code	<b>XC</b>	Cargo Prefix	<b>395</b>
ICAO Code	<b>CAI</b>	Telephony designator	<b>CORENDON</b>
For position flights the prefix "P" and for the ferry flights "F" will be added to the end of flight number			

### 1.5 TRAINING

#### 1.5.1 General

Chief Operating Officer is responsible to ensure all training(s) is performed in accordance with this chapter. Chief Operating Officer or any other authorized staff can give the training to the related handling company's staff when necessary.

Before assignment to job function all ground operation personnel shall receive initial training. This program applies to experience and unexperienced staff. Initial training covers familiarization, conversion and requirements.

The basic training requirements (initial / recurrent) as defined in GOM Chapter 1.5.3 is used with less details, therefore recurrent training duration is shorter, must be fulfilled, recorded and retained by the respective Ground Service Provider.

In accordance with the contracts between Parties, Corendon Airlines reserves the right to conduct audits of the contracted Ground Service Providers in order to ensure compliance with all applicable rules and

regulations, related with the training and certifying of concerned personnel. Those trainings shall be regularly reviewed and updated to remain relevant and current according to applicable legislation.

The recurrent training also should focus on the weak topics observed throughout the year. (e.g. complaints received for specific subjects such as check-in errors etc.)

Initial/Basic Training shall be provided before any duty is assigned to staff. Learning level must be checked in a written, oral or practical means to demonstrate adequate knowledge, competency or proficiency to perform duties, execute procedures or operate equipment.

Recurrent training or recurrent assessment shall be executed on a frequency not less than once during every 36-month period, except for recurrent training in dangerous goods. In some instances, other than DGR, recurrent training or assessment period specified by local regulatory authorities might be longer than 36 months (e.g., aerodrome driving license). In such cases such period can be accepted in stead of the 36 months.

## 1.5.2 Minimum Content of Training

Requirements for initial and recurrent training apply to all operational ground handling personnel who perform duties within the scope of ground handling operations. The GOM contains guidance and requirements for the training of ground handling personnel. Training must include;

- Familiarization training on general provisions of applicable regulations.
- In-depth training on requirements, (DGCA, IATA, ICAO, EASA) including policies, procedures and operating practices.
- Safety training on associated operational hazards,
- Human Factor Principles,
- Dangerous Goods Training in compliance within the Dangerous Goods Training (CBTA).
- A Security Training program in compliance within the Security Program.

**Reference:** IATA AHM, Dangerous Goods Training (CBTA), ICAO, Corendon Airlines GOM, Corendon Airlines OM PART-A, Corendon Airlines CCM, AHM560, SHT-OPS, Commission Regulation (EU) No 965/2012, EASA-OPS, FAA, IGOM, IOSA, ICAO Doc 9859 Safety Management Manual and other industry-related documents.

**Prerequisite:** The trainee is expected to have completed a basic Ground Handling course and be familiar with Aircraft & Passenger servicing concepts before the assignment for duty including on the job training by using On the Job Training Control Form.

**Objective:** Familiarization/ refreshing the knowledge of the attendees on specific Corendon rules and up-to-date operational requirements.

**Retention of Records:** The training record is retained for a minimum period of 36 months from the most recent training completion date including certificates, exams, OJT records etc.

The Internal Coordination Sheet is prepared and signed by the department manager for the documents whose retention period are exceeded and these documents are destroyed by shredding method.

Corendon Airlines has a system for the management and control of operational records to ensure the content and retention of such records is in accordance with requirements of the Authority.

Operational records are subjected to standardized processes for:

- i Identification
- ii Legibility
- iii Maintenance
- iv Retrieval
- v Protection, integrity, and security

- vi Disposal, deletion (electronic records) and archiving

The management of all ground handling operational documents, including but not limited to: Loading Instructions, Water Analysis Reports, and Baggage Manifest. Records will be collected via the email archive (gopmanifest@corendon-airlines.com) and securely stored on the Corendon Airlines server in accordance with the defined retention period.

### 1.5.3 Syllabus

All staff that performs operational duties in functions within the scope of ground handling must complete initial training and assessment prior to being assigned such duties, and subsequently receive recurrent training as appropriate to the role.

All staff should be recruited and selected with the appropriate level of proven experience, skills, and previous training (if applicable) to fulfill the defined job role. They shall subsequently receive the appropriate level of training for the tasks for which they are employed.

Corendon Airlines shall ensure personnel that perform operational duties in functions within the scope of ground handling operations, to include personnel of external service providers, complete:

- i. Initial training prior to being assigned to perform such operational duties
- ii. Recurrent training on a frequency not less than once during every 36-month period, except for recurrent training in dangerous goods (DGR - not less than once during every 24-month period)

For the different tasks of ground operations including external service providers, initial and recurrent training must include, but is not limited to:

- i. Airside Driving;
- ii. Load control;
- iii. Passenger Handling;
- iv. Baggage handling;
- v. Aircraft Handling and Loading;
- vi. Passenger Boarding Bridge;
- vii. Aircraft Loading Supervision;
- viii. Aircraft Ground Movement;
- ix. Cargo and Mail handling;
- x. Fueling Operations;
- xi. De/Anti-Icing Operations;
- xii. Dangerous Goods Training (CBTA)

The training syllabus has been defined in accordance with the requirements of IOSA, DGCA, IATA, ICAO, EASA etc.

#### a) Corporate Management System

1. Company Policy & Administration
  - Information about Company
  - Human Resources Procedures
  - Organizational Structure
  - Corporate Management System
  - Information Security Management System Requirements and ISO 27001 Principles
2. SAFA
  - Corendon Airlines SAFA Procedure
  - Responsibilities

- Information to avoid SAFA findings
- Categories of findings
- 3. Operation Manual
  - OM-Part A, B, C, D
- 4. Quality Management System
  - Quality Culture
  - Documentation Procedures
  - ISO 9001 process - Quality Management System Certificate
  - ISO 10002 - Customer Satisfaction – Complaint Handling Certificate (Air Passenger Rights)
  - IOSA Process
  - ISO 14001 Process - Environmental Management System Certificate
- 5. Safety Management System
  - Safety culture/philosophy
  - Safety Regulations
  - Hazard Identification and Risk Mitigation
  - Root cause and analysis
  - Safety Reporting
  - SMS Components of the Company
  - SERA Reporting System Components
- 6. Familiarization of International and National Regulations (Aviation Basic)
  - Turkish DGCA Regulations
  - EU Regulations
  - EASA Regulations
  - Air Ops
  - IATA Regulations
  - ICAO Regulations

## b) Airside Driving

Airside driver training for ground handling personnel typically addresses the following subject areas:

1. General
  - Role and responsibilities of vehicle Operators
  - Vehicle equipment standards
  - Hazards of airside driving
  - Reduced visibility procedures
  - Accident and incident reporting procedures
2. Ramps (aprons), stands and airside roads
  - Familiarization with ramp layout, operational stands, vehicle corridors, airside roads, aircraft taxi lanes
  - Airport rules, regulations and/or procedures pertaining to airside vehicle operations
  - Procedures for crossing aircraft movement areas
  - Pedestrian crosswalk rules
3. Maneuvering area
  - Identification of obstacle free areas, limited access areas
  - Airport regulations and requirements
  - Air Traffic Control
  - Airport layout
  - Maneuvering area driving
  - Radio communication requirements and procedures
  - Aircraft familiarization

## c) Passenger Boarding Bridge

- Standard operating procedures;
- Bridge control system, including emergency switches, cut-offs and buttons;
- Out-of-limits procedures (for returning bridge to normal working limits);
- Back-off procedures and application;
- Manual wind-off procedures;
- Accident and incident response procedures;
- Accident and incident reporting procedures (airport, provider);
- Fire procedures (bridge or aircraft)

**d) Passenger Handling and Baggage Handling (GOM Procedure)****1- Passenger Handling Terminology and Passenger Categories**

- Definitions
- Introduction and Definition of all relevant (printed) handling material
- Wheelchair Types,

**2. Visa, Passport and Travel Documents, INAD & Deportee**

- Valid Travel Documents (Tickets, Passport, visa etc.)
- Type of Visa, Schengen Countries and Schengen Visa

**3. Check-in and Boarding Procedure**

- Tickets of Tour Operators / Travel Agency
- Manual check-in procedures
- Corendon Tickets & ID Codes
- Lost Ticket Procedure
- Over-sales (Reasons of over-sales),
- Deadline-time for check-in
- Baggage Tag (types), UM Form, CIS, PIR etc.
- Allocation to Restricted and Special Seats
- Cabin seating considerations.
- Passengers Who Need a Medical Clearance
- Treatment of Special Passengers
- Pregnant Passengers,
- Admission of UM Passengers and Handling Rules,
- Admission Limits of Infants,
- Sick/ Invalid / Handicapped Passengers,
- Acceptance of PET in Cabin
- Acceptance of AVIH, DEAF / MUTE / BLIND, INAD, DEPO Passengers.
- Passenger Arrival, Transit and Departure

**4. General Baggage Acceptance and Baggage Handling-Irregularities**

- Baggage Handling Procedures (manual – checked – special baggage etc.)
- Baggage Allowance, Excess-Baggage Fee
- Hand luggage (Cabin), disallowed items (Dangerous Goods) in Cabin
- Checked Baggage, disallowed items (Dangerous Goods) in cargo hold
- Labeling (Delivery at A/C, Hand luggage label etc.)
- Lost & Found Baggage Handling (Damaged, Rush etc.)

**5. Specific Items as in Baggage / in Cargo, Acceptance of Liquids****6. Security Regulations, procedures****7. Load Control Consequences, coordination and procedures****8. Handling and boarding of weapons and authorized persons carrying weapons****9. Flight Irregularities**

- Delay Services,
- HIR

- Announcement
  - Recurrent
  - Customer Airline Services, Authorities etc.
10. Passenger Handling Messages
  11. Data-Document protection and security
  12. Emergency Response Procedures
    - Fire, dangerous goods, security etc.
    - Health and safety
  13. Departure Control Systems & CASAB & NETLINE
  14. Catering Services,
  15. Boarding bridge operation
  16. Cabin access door operation
  17. Communication procedures (customer airlines, load control, authorities, others)
  18. Aviation Basics

**e) Aircraft Ramp Handling (GOM Procedure)**

1. Ramp Handling Terminology
  - Bulk Loading, ULDs, AVI, Cargo, Baggage etc.
2. Description of Ramp Services
  - Potable water servicing
  - Aircraft toilet servicing
  - Cleanings services
  - Basic Ramp
3. Ramp Handling Equipment
  - APU, GPU, ASU, Passenger Steps, Conveyor, tow car, tow bar, ambulift etc.
4. Airside Safety
  - Safety philosophy
  - Safety Regulations
  - Airside hazards
  - Airside marking and signage
  - Airside safety supervision
  - Personal Protection
  - Fuel Spillage
  - Foreign Object Damage Prevention
  - Bad Weather Conditions on ramp
  - Walk around check
  - Position of servicing equipment
  - Passenger embarkation/disembarkation procedures
5. Aircraft maneuvering area / movement operations
  - Operation of Ground Services Equipment
  - Equipment-aircraft connect and disconnect procedures
  - Aircraft ground movement standard verbal communications (ground-flight deck)
  - Aircraft ground movement standard hand signals (ground-flight deck, ground-ground)
  - Aircraft marshalling
  - Aircraft ground movement assistance
6. Irregularity/incident/accident/damage/spillage reporting procedures
7. De-icing/Anti icing
  - Common standards, regulations and recommendations including local rule and restriction
  - Hazard of snow, ice and frost
  - Safe operation of equipment and de/anti-icing operation including aircraft critical area
  - Definitions

- Procedures
  - De-icing/Anti-icing treatment
  - De-icing Fluids characteristics and application, and limitation of holdover time
  - De/anti icing codes, communication and coordination
8. Loading and Unloading
- Principles of bulk loading and unloading
  - Ramp Baggage Handling
  - Handling of loads that require special attention
  - Consequences of load damage and spillage
  - Manual handling of load
  - Aircraft limitations
  - Special Cargo
  - Loading Instruction form
  - Loading Messages
9. Fueling and De-fueling
- Safe operation of equipment
  - Fueling and De-fueling procedures
  - Emergency Procedures
  - Fuel spillage avoidance response
  - Aircraft specific training
10. Special Loads, Marking, Labeling
11. Aircraft cabin/cargo access doors
12. Aircraft Arrival/Departure Procedures
13. Aircraft Towing/Pushback Procedures
14. Airside Driving
15. Boarding Bridge Operations
16. Ramp Baggage Handling
17. Aircraft Loading Supervision
- f) Load Control and Communication & Cargo/Mail Handling (GOM Procedure)**
1. Weight and Balance Theory and Documentation
- Aircraft Weight Definitions
  - Trip Fuel, Block Fuel, Taxi Fuel
  - Trip Info,
  - weight and balance form
  - Operational data
  - DOW-DOI Table
  - Limitations
  - Last Minute Changes
2. Rules for Load Planning and Messages
- Loading preparations, Loading Instruction, bulk loading
  - Load restraint rule: nets, tie-down, volume restraint
  - Applicable weights for Crew,
  - Passenger and Baggage weights for Charter Flights and Scheduled Flights
  - Cargo weights,
  - Equipment in Compartments,
  - Catering Materials and Flight Kits.
  - Definitions of Time, Addressing, Delay Messages
  - Delay Codes, Flight Movement Messages and Examples, Load Distribution Message
  - Examples Ad-hoc Schedule Messages (ASM) & Flight Disposition Message (FD)
  - Load Sheet

3. Cargo Handling Terminology
  - Consignee, Consignor
  - Charge weight, collect weight
  - Airway bill, Cargo Manifest
4. Acceptance of Cargo
  - Acceptance requirement/procedures (documents, packing, labeling, storage etc.)
  - General Requirements for shippers
5. Special load and cargo irregularities
  - Perishable, valuable cargo, oversized cargo, lives animals, human remains, dangerous goods etc.
6. Cargo Messages
  - Freight Forward Messages (FFM)
  - FWB messages
7. Cargo Handling Documents
  - Airway bill, Cargo Manifest
  - Corendon Cargo Label
  - Corendon AWB stock numbers
8. Aviation Basics
- g) Dangerous Goods**

Please refer to Dangerous Goods Training Program.
- h) Security**
  - Security Awareness
  - Airline Security
  - Handling of Potentially Unruly Passengers threatening Security
  - Interview with Passengers and Travel Documents
  - Communication and Body Language
  - EXAM
- i) Human Factors Principles**
  - General Introduction to Human Factors
  - Safety Culture/ Organizational Factors
  - Human Error
  - Communication skills
  - Stress
  - Fatigue Management
  - Human Performance & Limitations
  - Environment
  - Procedures, Information, Tools and Practices
  - Communication
  - Teamwork
  - Professionalism and Integrity
  - Organization's Human Factors Program
- j) On the Job Training**
  - General
  - Check-in
  - Ramp / Operation
  - Cargo

**Notes:**

- At least two complete operations must be observed during on the job training.
- OJT shall be observed by GOP Staff who have an experience of minimum three years.

- OJT shall be performed within 1 week after Initial training course completed.
- OJT control list form shall be used for the evaluation. This form is also added on Chapter 10 of this manual.
  - Chief Operating Officer shall ensure the training programs completed by ground handling operations personnel are reviewed and updated once in a year to remain relevant and current.
  - Training for personnel that operate a vehicle in the performance of duties in air side operations is supplied by state authority.

## 1.5.4 Ground Operation Department Initial Training Program

Day	Course Name	Course Notes & Reference	Hours
DAY 1	Corporate Management System		
	Company Policy & Administration	HR Procedures & Corp. Manual	1 hour
	SAFA	SAFA Procedures	1 hour
	Operation Manual	OM Part A & B & C & D	1 hour
	Quality Management System	Quality Manual	1 hour
	Safety Management System	SMS Manual	3 hours
	International and National Regulations	Internal and National Reg.	1 hour
DAY 2	Passenger & Baggage Handling		
	Passenger Handling Terminology	IATA AHM & GOM	1 hour
	Visa, Passport & Travel Documents, INAD & DEPORTEE	IATA AHM & GOM	1 hour
	Check-in/Boarding Procedures,	IATA AHM & GOM	1 hour
	General Baggage Acceptance, Baggage Irregularities	IATA AHM & GOM	1 hour
	Specific Items as in baggage/in Cargo Hold, Acceptance of Liquids in Cabin	IATA AHM & GOM	1 hour
	Flight Irregularities	IATA AHM & GOM	1 hour
	Passenger Handling Messages	IATA AHM & GOM	1 hour
	Air Passenger Rights	Regulation (EC) No 261/2004	1 hour
DAY 3	Aircraft and Ramp Handling		
	Ramp Handling Terminology and Equipment	IATA AHM & GOM	1 hour
	Ramp Safety / FOD/ Rules For Load Planning	IATA AHM & GOM	1 hour
	Fueling & Defueling	IATA AHM & GOM	1 hour
	Engine start-up and Push-back Procedures	IATA AHM & GOM	1 hour
	De-icing, Anti-icing	IATA AHM & GOM	1 hour
	Loading & Unloading	IATA AHM & GOM	1 hour
	Special Loads , Marking & Labeling	IATA AHM & GOM	1 hour
	OCC	OCC Procedures	1 hour
DAY 4	Load Control – Communication & Cargo Handling		
	Weight & Balance Theory and Documentation	IATA AHM & GOM	1 hour
	Rules for Load Planning and Messages	IATA AHM & GOM	2 hour
	Cargo Handling Terminology	IATA AHM & GOM & COM	1 hour
	Acceptance of Cargo / Handling Documents	IATA AHM & GOM & COM	1 hour
	Special Loads / Cargo Irregularities	IATA AHM & GOM & COM	1 hour
	Cargo Messages	IATA AHM & GOM & COM	1 hour
	Cargo Handling Documents	IATA AHM & GOM & COM	1 hour
DAY 5	Dangerous Goods CBTA & Environmental Management System		
	Understanding the basics of dangerous goods	IATA DGR CBTA	2 hour
	Transporting cargo/baggage	IATA DGR CBTA	1 hour
	Collecting safety data	IATA DGR CBTA	1 hour
	DGR EXAM	--	1 hour
	Environmental Management System	--	1 hour
DAY 6	Security		
	Security Awareness	Security Manual & GOM	2 hours
	Aviation Security	Security Manual & GOM	2 hours
	Potentially Disruptive Passengers	--	1 hour
	Passenger Procedures	--	1 hour
	Communication	--	1 hour
	SECURITY EXAM	--	1 hour
DAY 7	General Review & Human Factor Principles & Final Exam		
	Occupational Health and Safety	--	1 hour
	Human Factors Principles	ICAO Doc 9683	2 hours
	Catering Services	In-flight Process	1 hour
	Departure Control Systems & CASAB & NETLINE	--	1 hour
	General Review	--	1 hour
	Information Security	--	1 hour
	FINAL EXAM	--	1 hour

\*Each lesson hour is limited to 50 minutes and 10 minutes break time.

- a. The employee who is assigned at any positions other than the positions specified in item b below, will receive the initial trainings in the table above.
- b. The employee who is assigned at one of following positions in the department:
  - Ground Operation Department Driver
  - Administrative Officer
  - Senior Ground Operations Supervisor/Digital Projects
  - Senior Ground Operations Supervisor/Handling Contracts
  - Ground Operations Manager – Base Development and Cargo
  - Any position in Inflight Sales department
  - PSS/DCS Officer

will receive the following initial trainings:

- Quality Awareness
- Information Security
- Occupational Health and Safety
- Safety training in compliance within Corendon SMM Manual
- Security training in compliance within SHT 17.2
- Environmental Management System

**1.5.5 Ground Operation Department Recurrent Training Program**

Ground Operation Department Recurrent Training Program is as below. Recurrent training is implemented once in every two years.

Day	Course Name	Course Notes & References	Hours
DAY 1	Ground Operations Manual	GOM	2 hours
	Passenger and Baggage Handling	IATA AHM & GOM	3 hours
	Aircraft and Ramp Handling	IATA AHM & GOM	3 hours
DAY 2	Load Control – Communication	IATA AHM & GOM	2 hours
	Cargo Handling	IATA AHM & COM	2 hours
	Air Passenger Rights	Regulation (EC) No 261/2004	1 hour
	OCC	OCC Procedure	1 hour
DAY 3	SAFA	SAFA Procedures	1 hour
	Quality Management System	Quality Manual	1 hour
	International and National Regulations	International and National	1 hour
	Human Factors Principles	ICAO Doc 9683	1 hour
	FINAL EXAM	--	1 hour

*\*Each lesson hour is limited to 50 minutes and 10 minutes break time.*

**Note:** Information Security and Environmental Management System recurrent trainings are given yearly as e-learning.

Security, SMS and Dangerous Goods recurrent trainings are not included in above table.

Security Recurrent training is given in accordance with SHT 17.2 in every 3 years.

SMS Recurrent training is given in accordance with Corendon SMM Manual.

Dangerous Goods Recurrent training is given in accordance with the regulation of Dangerous Goods Training (CBTA) in every 2 years.

- a. The employee who is assigned at any positions other than the positions specified in item b below, will receive the recurrent trainings in the table above.
- b. The employee who is assigned at one of the following positions in the department:

- Ground Operation Department Driver
- Administrative Officer
- Senior Ground Operations Supervisor/Digital Projects
- Senior Ground Operations Supervisor/Handling Contracts
- Ground Operations Manager – Base Development and Cargo
- Any position in Inflight Sales department
- PSS/DCS Officer

shall have the following recurrent trainings:

- Quality Awareness
- Information Security
- Occupational Health and Safety
- Safety training in compliance within Corendon SMM Manual
- Security training in compliance within SHT 17.2
- Environmental Management System

#### **1.5.6 Pass Standards**

- a. Examination is mandatory for “DGR” and “Final Exam”. Passing “Final Exam” is required after completion of initial / recurrent Ground Operation training. Pass standards for these examinations have to be % 80.
- b. Practice is mandatory for “Weight and Balance”. The result of this practice shall be satisfactory by the instructor.
- c. After completion of Ground Operations Initial Training, a certificate will be given to the successful trainees.
- d. If the trainee cannot reach these requirements, an extra 3 days will be given to him/her for preparation before the last examination.
- e. During on the job training, the trainee has to reach “level 2” or “level 1”. If the result is “level 3 or below” additional 2 flights observations should be performed. (OJT requires a demonstration of adequate knowledge, competency and proficiency to perform duties, execute procedures and/or operate equipment.)
- f. If the trainee cannot reach above requirements, he/she will be failed and terminated.
- g. Completion of initial training and the demonstration of adequate knowledge, competency and Proficiency to perform duties, execute procedures and/or operate equipment are mandatory prior to being assigned for duty.

#### **1.5.7 Familiarization of Agencies**

- a. Corendon Airlines GOM is provided to all agencies before the first flight.
- b. Agency representatives are briefed by the Chief Operating Officer before the contract comes into force.
- c. When deemed necessary by the Chief Operating Officer, (in case of managing change, systematical changes, etc...) training will be given to the agencies / Handling Companies.
- d. In case of training request from third parties, Corendon Airlines will supply this request and assign an instructor as soon as possible.

**1.5.8 Training in case of Job Interruption**

The following training process shall be applied in cases of health issues, military service or pregnancy. This applies to Corendon Airlines Ground Operations personnel, as well as to external service provider personnel, in the event of job interruption, as per IATA AHM 1110, Section 4.

The Ground Operations Instructor will conduct the training requirements for the Ground Operations department.

Corendon Airlines shall ensure completion of the aforementioned training process through auditing, inspections, postal audits, etc.

Period of Absence	Action
Up to 3 months	<ul style="list-style-type: none"> <li>Brief the employee on any procedural, organizational or equipment/infrastructure updates/changes that might have occurred during their absence.</li> <li>The briefing shall be documented and filed accordingly.</li> </ul>
Over 3 and up to 12 months	<ul style="list-style-type: none"> <li>Brief the employee on any procedural, organizational or equipment/infrastructure updates/changes that might have occurred during their absence.</li> <li>The briefing shall be documented and filed accordingly.</li> <li>On the Job training should be delivered.</li> <li>Should any gaps in competence be identified, a period of requalification training shall be initiated.</li> </ul>
Over 12 and up to 24 months	<ul style="list-style-type: none"> <li>Brief the employee on any procedural, organizational or equipment/infrastructure updates or changes that might have occurred during their absence.</li> <li>The briefing shall be documented and filed accordingly.</li> <li>Deliver requalification training as required, including a documented, formal assessment of competence, as per initial training, to confirm the employee remains competent to perform that role..</li> </ul>
More than 24 months	<ul style="list-style-type: none"> <li>Initial training program(s) to be delivered.</li> </ul>

**1.5.9 Ground Operations Instructor**

- Instructors need to have knowledge on technical aspects of related training subject and training techniques, so that the subject is fully covered and questions can be correctly and adequately answered. Instructors must be able to determine whether a training program will achieve its objectives or not.
- Ground Operation Instructor** shall have following minimum qualifications:

<b>Education:</b>	Must have acquired a high school certificate or equivalent approved by the Ministry of education
<b>Experience:</b>	At least 1 year working experience in civil aviation and at least 6 months in Corendon Airlines. Must have at least 1 year professional experience on related training and checking subject.
<b>Foreign Language:</b>	English- Upper Intermediate
<b>Computer Skills:</b>	MS Office, Outlook

<b>Technical Knowledge:</b>	Must have completed Train the Trainer Course or Pedagogic Formation Course or must have Human Factors/CRM Course concerning the training subject.
-----------------------------	---

- The Instructor shall have technical and professional knowledge of the followings for their training subjects:
  - i. Passenger Handling
  - ii. Ramp Handling
  - iii. Dangerous Goods
  - iv. Cargo Handling
  - v. Load Control and Communications
  - vi. Human Factors / CRM
  - vii. De/Anti- Icing
  
- The instructor shall also attend the recurrent courses excluding his/her training scopes. Therefore he/she completes the recurrent training program. This procedure is also applied for the instructor who is responsible for cargo operations.
  
- **Ground Operations Instructor** responsibilities are:
  - To keep himself / herself updated with related company manuals as well as relevant ICAO, EASA, IATA, DGCA regulations and related documents,
  - To prepare related Ground Operations Training syllabus including initial and recurrent trainings according to applicable Turkish and international regulations and company standards
  - To prepare training material and presentations about related trainings; review and revise them at least once a year, or more frequently as required, to ensure that:
    - i. The training program and modules meet current and expected needs;
    - ii. All training material and training plans are up-to-date and meet the operational and regulatory requirements.
    - iii. The content of all training program and material is reviewed and updated in case of any need (standard change, regulation change, etc.) and in conjunction with published updates (AHM, DGR, LAR, Perishable etc.) to ensure that it remains current.
  - To perform and maintain Ground Operations Trainings,
  - To submit a copy of training material and presentations to the Chief Operating Officer to be kept as a training record.
  - To ensure training record forms are filled out after training,
  - To perform examinations at the end of the training, if applicable.
  
- **Dangerous Goods Instructor** Please refer to OM Part D for the detailed information

#### 1.5.10 Ground Operation Inspector

- Ground Operations Inspectors perform product audits on the subjects in which they are qualified.
- They should have at least 6-month operational experience and know-how on the related subject.
- Ground Operation Inspectors are assigned by the Chief Operating Officer.
- The list of inspectors is kept in the form of CA-GOP-INS.
- The Ground Operation Inspectors should complete the Ground Operation Initial training.

## 1.6 COMPLIANCE MONITORING PROGRAM

Corendon Airlines has a compliance Monitoring Program that provides for auditing of flight and Ground Operations functions at planned intervals to ensure the organization:

- Complies with regulatory and internal requirements;
- Satisfies stated operational needs;
- Produces desired operational safety, security and quality results;
- Continually identifies hazards, undesirable conditions and areas requiring improvement.

The Ground Operations Department has an integral part in quality assurance of operations and performs:

- Supplier selection, evaluation for ground handling services.
- Product audits related to operational activities.
- Audits results and follow up.
- Analysis of operational data and sharing result with management.
- Communication with authorities, suppliers and other related parties.
- Keep informed about recent development in aviation standards and regulations.

The Ground Operations Management shall ensure significant issues arising from handling operations, quality assurance and risk management are subjected to management review meetings, safety action group meetings and with other written statements.

(See details in Corendon Airlines Compliance Monitoring Manual)

## 1.7 Supplier Selection

IATA Standard Ground Handling Agreement shall be executed with external service providers at the stations where Ground Operation activities are being performed. This contract shall include the followings:

- Definition of the service/product,
- GDPR Requirements,
- Quantity/Volume/frequency data as applicable,
- Acceptance Criteria,
- Terms and Conditions,
- Cost and payment details,
- Communication means
- Information Security and confidentiality requirements
- Safety and Security Requirements

The Chief Operating Officer will create a list of the potential suppliers with good reputation in the market and then a Request of Proposal is issued.

The company form named Handling Agreement Questionnaire (CA-GOP-HAQ) is used for the supplier selection assessment.

This form shall not be filled by the contractors with whom Corendon Airlines has had a long-term working relationship and who has already been audited. In addition, the specified selection process might have limited value at a location where there is only one service provider available (e.g. station monopoly, government/authority-provided services)

After the proposal are collected and compared between eligible suppliers, the supplier selection is being made. The Chief Operating Officer shall verify that the selected supplier can meet the contract requirements before the contract is executed. The risk assessment including safety, quality, security, environmental and information security aspects are performed.

A confidentiality clause acceptable to Corendon Airlines which is included GDPR and Information Security requirements shall be included in the contract or a separate Confidentiality Agreement can be executed.

Please see Contracting Procedures Chapter 5, and Product and Service Procurement Procedure Chapter 4 for more details.

### 1.8 Supplier Evaluation

The services that have immediate effect on safety, quality, security and performance level of the company, suppliers shall be evaluated and approved. The Chief Operating Officer is responsible to select suppliers and ensure their conformity to company standards including safety and/or security of ground operations, information security and environmental aspects. Typical resources for this verification are as follows:

Audit Reports (external, internal)

Audit methods (on-site, desktop, remote, product audits)

Feed backs (all via defined communication channels)

Delay codes and reasons' analyze

Gain on ground time reports from Flight crew

Performance measurements

On-site reports

Visiting reports

Safety Analysis

Employee feedbacks

Safety Surveys

Any feedback by means of communication channel (including verbal feedbacks)

DGR Occurrence Report

Data log records

Handling Irregularity Reports

Customer Complaints

The evaluation of the suppliers including the security, safety, quality and performance is recorded by a separate form named CA-GOP-IRF Irregularity Follow up Form.

The evaluation of the suppliers including ISO 9001, ISO 14001 and ISO 27001 certifications are performed within the specified time limitation by a separate form named CA-GOP-SEF form.

## 2 PASSENGER & BAGGAGE HANDLING PROCEDURES

### 2.1 PASSENGER DEPARTURE & CHECK-IN PROCESS

#### 2.1.1. Flight Information Boards

Handling Agents and ticket sales agents will ensure that Corendon Airlines flights details, Corendon Airlines Company Logo, Dangerous Goods Notifications and Air Passenger Rights Signs are correctly in place and indicated on flight information boards and ticket sales counters.

Corendon Airlines ensure that Dangerous Goods Notifications is presented for the passenger acknowledgement when the online ticket is being purchased and online boarding pass is issued by confirming Corendon Airlines Condition of Carriage Policy.

#### 2.1.2. Passenger Pre-Flight Preparation

Handling Agents should prepare check-in for flights in accordance with Corendon Airlines check-in policy prior to the opening of web or airport check-in, and to verify all necessary data has been transferred into the check-in system correctly.

- Review the booking status.
- For multi sector flights with an active blocked space agreement, check the allotment to ensure the block of seats, as agreed, is guaranteed to the other station.



*To enable allocated seating on three sector flights, before check in the departure station shall send a provisional Seats Occupied Message (SOM) to both destinations. Both destination stations shall then issue seats accordingly, using only those seats allocated to their stations.*

*Due attention should be paid to seat requests as it may be necessary to allocate seats in advance for use by the last departure station.*

*After closing the check in, a final SOM shall be sent to destinations.*

- Confirm the Passenger Name List (PNL) and Additions and Deletions List (ADL) were properly transmitted and match the booking status.
- Block seats crew, weight and balance, and if seats are unserviceable.
- Confirm the seating plan is set according to the actual aircraft type and version.
- Review the flight remarks which are sent by Corendon Airlines Ground Operations.
- Record passenger status on PNR, if applicable.
- Review the boarding time, departure time, and gate. Brief staff about the reason for any delays.
- Apply payload restrictions, if any.
- Check the passenger list and Special Service Requests for special passengers (e.g. WCH, UM, etc.) and pre-assign as per Corendon Airlines policy and according to the aircraft type.
- The responsible check-in staff should be properly briefed with information regarding the SSR sent by Corendon Airlines Ground Operations.
- If not pre-reserved, prepare seating for families traveling with infants or children.
- Ensure flight status is open for web check-in if applicable.
- Check-in is opened once the pre-flight preparation is complete.



*Pay maximum attention to allocate Pre-reserved/Pre-booked passengers seats, if any change is mandatory please report it to Corendon Airlines Ground Operations immediately with the reason.*

#### 2.1.3. Opening of Check-In Counters

- **Prior to opening the check-in counters, handling agents should;**
  - Start and test equipment's.
  - Ensure scales are functioning.
  - Stock boarding cards and bag tags to the printers.
  - Ensure adequate stock of any other required tags such as limited release, indemnity form, passenger irregularity form etc.
  - Display Corendon Airlines required signage, both electronic and manual versions.

- Ensure Dangerous Goods notifications are prominently displayed at the check-in area as well as ticket offices, baggage drop-off areas, self-serve check-in areas, boarding areas, transfer counters and baggage claim area. These notices shall include visual examples and be displayed prominently and in sufficient number at each of the places at an airport where passengers are processed and clearly at any other location where passengers are checked in.
- Prepare check-in queues, baggage gauges, information boards, etc.
- Place the Air passenger rights signage at check-in desks or screens.

➤ **After the completion of the above items;**

- All counters used for check-in of Corendon Airlines passengers should clearly indicate the Company logo, flight number and destination(s). In case of a failure, contact with Corendon Airlines Ground Operations. The counters are to be opened for check-in 2.30 min prior the scheduled time of departure or the estimated time of departure.

Exemptions:

- At AMS, BRU, TLV, AYT and DUS ( DUS non schengen flights) check-in counters of passengers are opened 3 hours prior STD.
- Check-in counters of passengers are closed 1-hour prior STD

#### 2.1.4. Check in Procedure-General

- All passengers must report individually, as Corendon Airlines does not permit the unattended baggage to be checked and tagged in pools.
- Communication with passengers must always be kind. Ask the passengers to place his/her baggage on the scale, including cabin baggage. Verify final destination of the passenger. Check-in baggage and ensure that all baggage has been taken into account.
- If the passenger's name is not in PNL, please contact with Corendon Airlines Ground Operations immediately even the passenger has a ticket with correct information.
- If appropriate, check passenger's travel documents for which the IATA Travel Information Manual (TIM) should be consulted.
- Observe the special passengers and do not hesitate to ask their conditions. (Sick, incapacitated, pregnant, etc.)
- Ask %10 of total booked passengers if their baggage left free from restraint via using sampling method.
- Ask %10 of total booked passengers if the passenger carries his/her own baggage via using sampling method.
- Ask %10 of total booked passengers if they packed their own baggage via using sampling method.
- Collect and transmit Advanced Passenger Information (API) if required.



**Advance Passenger Information:** Many governments require airlines to submit advanced passenger electronic data (API) at specified times for disembarking passengers. Information is generally collected at the time of check-in, or provided from data collected during booking, and verified during presentation of the travel document. As per Corendon Airlines instructions, collect API data at the time of check-in, or review data already provided. Transmit API data at pre-arranged times to recipients specified by the Corendon Airlines and State/Border Authorities. Always protect passenger's personal information and securely dispose of any related paperwork not kept on file.

The APIS collecting and sending is mandatory and should send after every flight from foreign countries to Turkey according to the regulations of Turkish Authorities. Please contact with Corendon Airlines Ground Operations to learn more about requirements.

- Where automated DCS is not available or in case of DCS failure, apply established manual check-in procedures. Local back-up procedures must be established in every station and tested regularly. Inform Corendon Airlines Ground Operations about your stations back-up procedure.
- For the passengers who make check-in remotely or at automated check-in facility, an information that describes the types of DG that are forbidden for transport aboard an aircraft; and is presented in a manner that does not allow completion of the check-in process until the passenger, or a person acting on behalf of the passenger, has acknowledged that they understand the restrictions on

dangerous goods in baggage shall be stated in flycorendon.com / corendonairlines.com and Corendon Airlines conditions of carriage.

- **Personal Items:** Personal items comprises of all articles which the passenger can transport in the cabin without being tagged and weighed. These articles will not be registered on the ticket and the passengers themselves are responsible. Only the items mentioned below will be considered personal items. All other types of articles shall be handled as baggage.
  - i. Lady's handbag,
  - ii. Reading material for the flight
  - iii. Overcoat, small blanket.
  - iv. Walking stick
  - v. Small camera and/or binoculars
  - vi. Infant's carrying basket
  - vii. Fully collapsible chairs and/or prosthetic devices for passenger's use
  - viii. Laptops, iPads, Tablets etc.
- Corendon Airlines allows a passenger to purchase a ticket for an item, approved by a Corendon Airlines Service Center, which is too fragile or bulky to be handled as checked baggage. Examples of cabin-seat baggage may include large or valuable musical instruments, diplomatic bags, works of art, scientific instruments, media cameras, artifacts, garment bags and similar items of a delicate nature or unusual size.
- These items can be carried on board and transported in a seat, provided that certain special rules are followed.

### SPECIAL RULES

#### The item:

- must be packaged or covered in a manner to avoid possible inquiry to passengers and cabin crew members.
- must be placed on the cabin seat and secured by a safety belt or restraint device having enough strength to eliminate the possibility of shifting under all normal anticipated flight and ground conditions.
- must NOT impose any load on the seats that exceeds the load limitation for the seats.
- must NOT restrict access to or use of any required emergency or regular exit, or aisle(s) in the cabin.
- must NOT obscure any passenger's view of the seat belt sign, no smoking sign or required exit sign.
- preferably placed at the window seat.

#### The item:

- must NOT exceed 135 x 40 x 35 cm in dimensions.
- must NOT exceed 75 kg in weight.
- must NOT be placed any regular or emergency exit row.
- must NOT be placed at the aisle seat of the cabin.
- must NOT obscure any customer's view of "seatbelt," "no smoking" or "exit" signage.
- must NOT contain dangerous goods.

#### Additional requirements:

- One extra seat must be reserved and paid adjacent to the owner.
- Item must be confirmed in advance by Corendon Service Center and applicable charges paid.

- **Acceptance of Stand-by Passenger on Flights, Priority of Passenger Holding Free/ Reduced Tickets:** The following instructions concern the passengers holding free or reduced priced tickets.



*Passengers have to be in possession of a ticket showing the ID-Status.*

*These tickets holders have to be treated as stand-by passengers.*

*If the handling company does not have an approval letter or SSR, Corendon Ground Operations shall be contacted for confirmation.*

*Priority of free/reduced tickets with respect to other stand-by passengers.*

*A distinction is made between two categories of non-revenue passengers:*

*Service passengers, travelling on duty or for business purposes;*

*Free passengers, whom are travelling for private reasons.*

*Any passenger who is travelling based on a free ticket or reduced fare is considered a standby passenger.*

*All non-revenue passengers must identify themselves by means of a passport and present a service ticket with priority number.*

*Non-revenue passengers and their baggage can be checked in on stand-by (no seat allocated). Non-revenue passengers can proceed to the gate.*

*As soon as the check-in is closed, available seats can be assigned to non-revenue passengers at the gate, based on priority number. If there are no seats available after check-in has closed, jump-seats can be requested from the crew. The purser must be advised of the presence of non-revenue passengers and their seat allocation.*

- **Acceptance of Jump Seats:** The transportation of passengers, revenue or non-revenue not being Corendon Airlines employees or their dependents on jump seats is not permitted. Any overbooked passenger has to be denied boarding and the tour operator or Corendon Airlines shall take necessary actions.
- Jump seats for Corendon Airlines employees and their dependents (travel status IDA) may only be granted with the prior consent of flight captain. For more information, follow the procedure in OM Part A under the name of “vacant crew seats – cockpit & cabin”
- Fare paying passengers may NOT travel on jump seats under any circumstances.

## 2.1.5. Boarding Procedure-General

- Boarding procedures are a crucial part of the aircraft turnaround. Efficient coordination between crew, agents and handling staff, timely announcements and accurate visual information will allow the saving of time. Such well executed turnarounds present a positive image for the airline.
- Place the Air passenger rights signage at boarding gates or keep the Air Passenger Right brochure on hand and deliver it to the passenger when requested.
- After the flight crew arrives the aircraft; if there are no restrictions (ctot, terminal facility or any technical issue on aircraft) to start boarding, the boarding will start immediately according to parking bay (remote or aerobridge) after the briefing is held with the flight crew.
  - If there is a CTOT less than 01:00 hour (according to STD), the operation will continue as normal.
  - If there is a CTOT more than 01:00 hour (according to STD), the boarding will start after coordinating with the flight crew.
- Boarding shall start minimum -50 minutes before STD/ETD for remote parking stands and -40 minutes before STD/ETD for bridge parking stands and boarding closes 25 minutes prior to departure by coordinating with the crew

**Note: The loadsheet must be delivered to the crew at least 25 minutes before STD.**

- **Passengers Eligible for Pre-boarding:** The following passengers are eligible for boarding before other passengers and whenever possible, these passengers should be identified and pre-boarded before boarding starts:
  - Passengers with reduced mobility
  - Mothers with infants/small children
  - Children traveling alone (UM)
  - Deportee/ Inadmissible Passenger

- The passenger who purchases Priority Boarding service at the check-in desk
- The passenger with Premium Ticket Fare
- **Preferred boarding sequence (ROW by ROW)** To ensure a comfortable and easy boarding process, passengers have to be advised and directed to board the aircraft as follows:
  - **If aircraft is parked at remote/open position** and unless instructed otherwise in advance; Passengers must be informed at the Gate/waiting lounge to embark from the front, respectively rear door, according to below seating information:
    1. Passengers whose are seating between 01-15 rows, should use front door.
    2. Passengers whose are seating after the row 16, should use rear door.
  - **If aircraft is parked at pier/terminal position** and unless instructed otherwise in advance; the goal is to divide the aircraft into three boarding sequences. In the following examples; the three boarding sequences are chosen as follows:

A/C Type	Row Numbers	Zone
B737-800/8 MAX	21-99	C
B737-800/8 MAX	10-20	B
B737-800/8 MAX	01-09	A
A320	21-99	C
A320	10-20	B
A320	01-09	A

- **Appendix-18 Boarding Announcement** form includes the sample of boarding calls process for both remote and air bridge positions.
- When Corendon Airlines utilizes a wet leased aircraft, it is mandatory to announce the actual company name flying the wet lease to the passengers.

**Note:** Please refer to Appendix-18 Boarding Announcement for the sample announcement.

**Reporting:**

- The related issues should be reported to [groundoperations@corendon-airlines.com](mailto:groundoperations@corendon-airlines.com) and are such as, but not limited to:
  1. Late arriving crew; if the crew arrives to the aircraft less than 1 hour according to STD.
  2. If the flight crew do not give boarding clearance without any reason.
  3. If base departure flights are not closed the doors before 15 minutes according to STD.
  4. If turnaround ground time exceeds 01:00 hour
- Whenever passengers are found to be missing at the gate, the Handling Company should learn their names and announcements made individually. Reconciliation of boarding passes and coupons and the head count should be done carefully and quickly to avoid unnecessary delays by the handling company.
- If any missing passengers occurred -25minutes before STD/ETD, commence offloading procedures and follow below instructions.



*If missing passenger(s) has baggage(s) in cargo start to search their baggage(s) in coordination with loading team. And inform flight crew about their status, request headcount from cabin chief.*

*If missing passenger(s) report on -15 minutes before STD/ETD, cancel baggage search.*

*If missing passenger(s) does not report after -15 minutes before STD/ETD, offload them and inform flight/cabin crew.*

*If missing passengers have no baggage in cargo, wait them until -15 minutes before STD/ETD, if not report offload them and inform flight/cabin crew.*

- The Handling Company should always perform an identification (ID) check at the gate by matching the name on the boarding card with the name on the ID document. As well as verify if the picture on the ID document matches the face of the passenger.
- All cabin baggage must be checked for size and weight at check-in as well as at boarding gate, only one piece of cabin baggage may be carried (Infants have no allowance to carry cabin baggage). Baggage which are not meeting the carriage requirements must be taken in, labelled – using a limited release label - and stowed in the forward cargo hold. Before acceptance irregular cabin baggage to cargo compartment, consider below instruction.



*If any irregular cabin baggage detected at gate which the passenger does not reported at check-in, please apply irregular cabin baggage penalty fee.*

- **Head count process:** During boarding, boarding agent should check boarding cards and transit boarding cards of the passengers to verify the flight number and destination information with maximum care and attention.

Unless otherwise advised such as;

- Subcharter or wet lease-out flights,
- Where automated DCS is not available or in case of DCS failure
- Transit flights

Corendon cabin crew members will not perform head count of passengers. Once the boarding is completed, the aircraft access door will be closed by the cabin crew.

## 2.2 Passenger Arrival and Transit

### 2.2.1. Pre-Arrival

Review the pre-arrival information from DCS and/or messages (PSM, SOM, PTM...).

- Prepare for short connections if applicable
- Arrange facilitation for passengers requiring special needs and/or assistance
- Check requirements for any gate delivery mobility aids.

### 2.2.2 Arrival

- Prepare passenger boarding bridge, ensuring it is free of debris and position as per the standard height for the aircraft type.
- Secure the disembarkation route for passengers. If passengers are required to walk across the ramp, they must be supervised by Passenger Handling and/or Ramp Agent.
- Disembark passengers in accordance with Corendon Airlines Policies.
- Provide assistance to passengers requiring it. Communicate any delays in providing assistance services.

### 2.2.3 Transit Passenger

- Transit passengers may be allowed to disembark when scheduled ground time and local circumstances and facilities permit
- Certain categories of passenger should be escorted during the transit time.

- Local government requirements shall be applied regarding security of transit passengers up to and including screening requirements.

### 2.2.3.1 Disembarkation of Transit Passengers

Transit passengers may be allowed to disembark when scheduled ground time and local circumstances and facilities permit

- Passengers need special assistance shall be escorted during the transit time
- Provide each passenger with a transit boarding pass or instruct passengers to retain their original boarding pass.
- Inform passengers about boarding time and gate and available facilities
- Transit passengers must be re-secured when re-boarding the flight. (i.e. travel document checked, boarding status verified, and transit card collected)

Transit passengers should be permitted to leave the aircraft only after such an inspection if, for example, transit passengers are permitted to exit the aircraft to stretch their legs before re-embarking on the aircraft.

### 2.2.3.2 Transit Passengers Remain Onboard

There may be categories of passengers that stay on board if locally permitted. The aircraft during the transit stop, such passengers remaining on board are typically asked to positively identify their belongings, perhaps by placing them on their laps, while the security check or search is performed. Any articles found are typically treated as suspect and appropriate measures are taken to remove them from the aircraft. Therefore, Corendon Airlines ensure that any items left behind by disembarking passengers from such transit flights are removed from the aircraft or otherwise addressed appropriately before the flight departure.

### 2.2.3.3 Boarding Transit Passengers

- Transit passengers must be re-secured when re-boarding the flight, (i.e. travel document checked, boarding status verified, transit card collected),
- Board transit passengers before local passengers
- Re-secure the flight by checking travel documents and validating boarding status by collection of the transit card or review of the original boarding card. Validation may also be done using the flight manifest or DCS.
- The flight must be re-secured before door closure. If passengers are missing, apply the procedure for missing passengers. Check the manifest by matching the individual passenger's boarding pass and travel documents in case of need

### 2.2.4 Programmed Aircraft Change Route

Not applicable in Corendon Airlines but if it's required, following actions may be considered in coordination with Flight Crew:

- Advise cabin crew that all transit passengers must disembark with their carry-on baggage
- Distribute transit boarding passes (or instruct passengers to retain their original boarding pass) and inform passengers about boarding time and gate and available facilities
- Provide passenger assistance as required.
- In case of a change of configuration, assign passengers new seat numbers if applicable, or apply free/ open seating with the confirmation of PIC

## 2.3 SPECIAL CATEGORIES OF PASSENGERS

**2.3.1. Passenger with Reduced Mobility (PRM)**

It is defined by law that we should report in an appropriate matter of time which PRM's should need assistance on which flights. As a policy, Corendon Airlines offers passengers with a mobility limitation all necessary facilities to comfortable travel.

- The tour operator or passenger will send their request at least 48 hours prior to departure to Corendon Airlines Ground Operations and specify which type of assistance is required.
- Corendon Airlines Ground Operations will send the received requests at least 24 hours prior to departure to the managing bodies responsible for handling the mobility of PRM's.
- All PRM's requests received in less than 36 hours prior to departure, are considered 'ad-hoc' and will be handled as such. This means that these passengers may experience an appropriate stand by time, before the service they require can be supplied.
- PRM requests will be send by AYTOP7H or AYITXC with SSR subject one day before departure to the stations.
- If a passenger's special needs were not communicated at the time of booking, or a passenger is identified as a PRM or potential, MEDA case upon departure, take all reasonable efforts to accommodate the passenger. Ask appropriate questions and record required codes in the DCS.
- A Passenger with Reduced Mobility is a passenger whose mobility is reduced due to:
  - i. Injuries, physical and/or mental incapacity;
  - ii. Intellectual deficiency;
  - iii. Age (children, infants and elderly passengers);
  - iv. Illness;
  - v. Significantly impaired sight or hearing;
  - vi. Obesity;
  - vii. The status of Deportee, Custody or Inadmissible passenger.
  - viii. In need of Oxygen during flight.
- For all Airports following PRM instructions are applicable on all Corendon Airlines flights:
  - i. Ensure to assign the most suitable seat possible.
  - ii. Whenever possible, PRMs should pre-check at check-in and pre-board to the aircraft;
  - iii. Wherever possible, PRMs should sit at only A/F seats (window seats); and as possible to near the front door.
  - iv. PRM's shall not be seated on emergency over wing exit rows;
  - v. Electric Scooters - There is only one available space for mobile scooter on Corendon Airlines aircrafts cargo compartments;
  - vi. Electric Scooters can only be loaded upright Minimum 2 dimensions should lower than 86cm All considerations should arrange at check-in in coordination with loading team (folding, battery isolating, battery remove etc.)
  - vii. A passenger's own battery-driven wheelchair and battery-driven mobility aid, such as a mobility scooter, will be carried as checked baggage in the aircraft cargo compartment free of charge i.e. also above the passenger's free baggage allowance, but never in the cabin. In "PSM's" (Passenger Service Message) "SCOOTER/OWN" shall be shown.
  - viii. All wheelchairs, in particular those which are battery-driven, must be handled with utmost care to prevent damage and in accordance with dangerous goods regulations. (see chapter 8)
  - ix. The passenger is fully dependent on his wheelchair and may be severely inconvenienced, if his wheelchair is damaged or lost.
  - x. Please remember when loading the assistance equipment in the cargo compartment: LAST IN FIRST OUT!

**Limitations on PRM passengers:**

The total number of PRMs should not exceed the number of able bodied persons capable of assisting with an emergency evacuation.

**Boarding and disembarking the aircraft of PRM Passengers:** Arrange pre-boarding for the PRM passengers.

- Some airports do not use an air bridge and use aircraft stairs instead. If the PRM is unable to walk up or down the stairs arrange suitable means for the PRM to board and disembark the aircraft.
- **PRM notification to the crew:** the purser and commander shall be notified by the handling agent via Passenger Information List and verbally when PRM's are planning to be assisted on board. Information on passengers requiring any assistance at transit or destination aerodromes shall be forwarded to ground staff or handling agent at the respective station(s) by means of a Passenger Service Message (PSM).
- **PRM codes:** Corendon Airlines has no special PRM codes for its passengers, please refer IATA AHM176A Resolution 700 AIRIMP codes. (Such as WCHC, WCHS, and WCMP etc.)

### 2.3.2. Passengers on Stretchers (STCR)

- Passengers on stretchers are considered Medical Case passengers and must have a "Fit to travel by air carriage" medical clearance from a doctor.
- Stretcher equipment consists of stretcher technical accessories, sanitary kit and curtain.
- Only Corendon Airlines approved equipment shall be used in-flight.
- Installation / Removal of stretchers shall be performed by certifying staff. The Ground Operations Department is responsible for the transfer of stretcher to the related base.
- If there is no certified staff in the arrival destination, at least one certified staff shall attend the flight during stretcher carriage.
- In-flight stretchers are not to be used for transferring passengers from the airport to the hospital due to technical reasons. The ambulance's own stretcher must be used for such transfers.
- The Ground Operations Department has to be informed 2 days before the flight about the stretcher carriage. It is the responsibility of the Ground Operations Department to accept stretcher carriage with the coordination of Maintenance and the Flight Operations Department.
- It is customer's responsibility to arrange ambulance and hospital services. The Information about ambulance and hospital service shall be given to the Ground Operations Department by customers before the flight.
- For all aircraft passenger are to be embarked using the front door because of technical specifications.
- Stretcher passengers must be accompanied by someone else travelling. It must be stated in Cabin Information Sheet.
- Company escort is not provided.
- Medical clearance is needed 10 days prior to the flight which states that the passenger is "Fit to travel by air carriage." This clearance must be either in Turkish or English. If it is in another language it can be translated and approved by the Airport Authority or The Ground Operations Department or Airport Medical Staff.
- Passengers on stretchers shall be at the check-in desk at least 3 hours before the departure time.
- The last three rows of the Aircraft on the left side shall be used for the stretcher.
- The passenger using the stretcher should be boarded first by using an ambulance lift.
- Passengers are boarded with the coordination of the Cabin Chief, Pilot in Command, Supervisor and Certified staff.
- The arrival destination shall be informed by the handling company via SITATEX or e-mail.
- Corendon Airlines may charge a special price for carriage of a stretcher at least 9 (nine) times of full fare of the full fare ticket of that flight.
- Accompanying persons also pay for a full fare.

- In accordance with ICAO Appendix 9 and ECAC Doc 30 Part I, all related companies and authorities shall take their own responsibilities during the handling of reduced mobility passengers including stretchers.
- **Installation and Load Sheet Preparation of Stretcher:** The handling agency should be informed about number of blocked seats and final seat capacity of the effected section.
- Total number of seats blocked by the stretcher and number of the accompanying passengers” should be noted on the load sheet, LDM and PSM.
- For load sheet calculations, Decrease DOI by index of 2 and Increase DOW by 40 KG.
- Location of the stretcher should be marked on the cabin illustration.
- **Seat Occupations According to Aircraft Types:**

Aircraft Types	Seat Occupied	Installation	Remark
B737-800	9 Seats	Last three rows of the Aircraft on the left side.	Just 1 stretcher is allowed

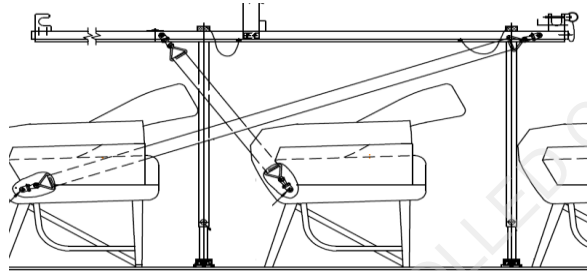

➤ **Position of Stretcher in Aircraft:**



- **Disembarkation of Stretchers:** Passengers disembark from the forward or aft door because of technical specifications depend of the aircraft specification.
- Passengers disembark with the coordination of the Cabin Chief, Pilot in Command, Supervisor, Certified staff and Medical Staff.
- Medical staff are responsible for the transport of the stretcher from the aircraft to the ambulance lift.
- Ambulance apron access shall be obtained by the handling company.
- **Oxygen for Stretchers:** Oxygen bottles, cylinders and/or tubes cannot be accepted for carriage.

**2.3.3. Expectant Mother (Pregnant Passengers)**

- Pregnant passengers will be accepted up to 36<sup>th</sup> week of pregnancy with ‘Indemnity form’, there is no need to doctor’s report. Corendon Airlines restricts air travel for uncomplicated single pregnancies beyond its 36<sup>th</sup> week. Indemnity form should fill after 24<sup>th</sup> week of pregnancy.

- For multiple pregnancies; pregnant passengers will be accepted up to 32<sup>nd</sup> week of pregnancy with 'Indemnity form', there is no need to doctor's report. Our company restricts air travel for uncomplicated multiple pregnancies beyond its 32<sup>nd</sup> week.

#### 2.3.4. Unaccompanied Minors (UMNR) and Young Passengers (YPNR)

- Children between 6 and 12 years of age may be accepted for travel alone providing that:
- It is mandatory to fill out the "Unaccompanied Minor Form" (please ask the sample form from [groundoperations@corendon-airlines.com](mailto:groundoperations@corendon-airlines.com)) in cooperation with the UM's parents by providing the UM personal data and flight details, as well as names, addresses and telephone numbers (always list mobile phone numbers if possible) of the persons escorting the UM to the airport at departure and picking up the UM at the airport of arrival.
- In addition, a UM wallet and a UM sticker have to be provided. The sticker has to be placed visible on the checked baggage. The wallet has to be filled out with UM personal details and flight details. Use the checkbox field to double check the content of the wallet:
  - i. Boarding Pass
  - ii. Passport
  - iii. UM Handling Advice (Unaccompanied Minor Form) in triplicate
  - iv. Booking confirmation for each single sector
  - v. Baggage tag
  - vi. The UM wallet should contain all necessary documents and must be carried by the UM at all times during the journey.
- The Passenger Information List must contain information about UM's travelling.
- UM's must be handed over from the responsible handling agent to the Purser of the flight personally.
- In general UM's must be boarded last, nevertheless after consultation with the crew, UM's may be boarded first.
- The arrival station has to be notified by PSM about UM's name, age, flight no. and routing.
- Unaccompanied minors should meet by handling staff up on the arrival.
- Unaccompanied minors should be mentioned in the Departure Signal.
- As a policy, maximum four UM's are accepted to Corendon Airlines Flights.
- UM shall not be seated at emergency. In case of 2 children on a row of 3 seats, the 3rd seat shall be occupied by an adult (16 year or older).
- Only if she/he can fly with the person who's adult (over 18 years old), then she/he does not count as UM.

**Note:** In case of the transportation of deportees and/or inadmissible passengers together with UMs on the same flight, then the UMs shall never be seated in the same row as the deportee and/or inadmissible person.

- Young passengers (12 years or older) can transport by their selves without any accompany.

#### 2.3.5. Infants and Children

- **Infants:** An infant is a child under the age of two years. They should be seated on the parent's lap and fastened with an infant belt during take-off and landing. Infants shall never be fastened while in their bassinet or together with an adult, with the same seat belt.
- If a bassinet does not fit into the overhead bin, it shall be labelled with a tag and sent to the cargo compartment. The bassinet may be placed on an empty window seat if there is a seat available next to the passenger. However, the infant must be fastened on the parent's lap during take-off, landing and turbulence.
- Passengers travelling with infants shall not be seated at exit row seats. Cabin crew or a passenger may need to use extra oxygen mask during walking in the aisle in case of possible decompression. Therefore; only 1 infant shall be allowed per complete seat row.

- The INF should be seated either A or F seats.
- Infants and their mothers will not be admitted to our Flights within 48 hours following birth even if a doctor report permitting travel is submitted. Between 48 hours after birth until the end of the seventh day following birth, infants and their mothers may be admitted to Corendon Flights based on a written doctor report permitting travel by air.
- Corendon Airlines does not accept a single passenger travelling with 2 or more children under 2 years of age. A passenger wishing to travel under these circumstances must inform their Tour Operator and/or Corendon Airlines and ask for an escort, which will be at a cost.
- It is forbidden for a passenger to carry 2 babies on his/her lap.
- The quantity of infant belts and infant life vests available on our aircraft is 10% of the number of passenger seats available.

AC Type	Passenger Seats	Standard			Max. No. To be carried with the addition of extra belts and LVs
		Infant Belt	Infant Vest	Life	
B737-800/8 MAX	189	20	20		28

- **Children:** A child is a minor between 2 and 12 years of age, having reached his/her 2nd birthday but not his/her 12th birthday.
  - Children must occupy an individual passenger seat and may not be seated in emergency exit rows.
  - Corendon Airlines Aircrafts are not equipped for the car seats, restraints devices and/or maxi cosi.
- **Known (infectious) childhood diseases**
  - A child which is infected with one of the childhood diseases listed below, shall not be accepted without a medical certificate (only stated in Dutch, English and Turkish) signed by an independent medical doctor. This medical certificate will indicate the disease is not contagious (anymore) and that it is safe to fly. This is for safety of crew and passengers on board the aircraft.
  - Following infectious diseases apply:
    - i. Mumps
    - ii. Whooping cough
    - iii. Measles
    - iv. Rubella
    - v. Scarlet Fever
    - vi. Fifth disease
    - vii. Chickenpox

**Note:** *If in any doubt, always consult a medical doctor.*

- **Groups**
  - A group is defined as a party of at least 09 passengers (not including infants), travelling together.
  - Check-in and accept all passengers individually.
  - Assign seats together, if requested, respecting any special seating requirements.
  - Issue baggage tags individually.
  - Each piece of baggage must bear the respective passenger's identification
  - Exception: Bag tags for family members travelling together may be issued on one family name.
- **Minor-groups (sporting teams, special organizations etc.)**
  - May be accepted for check-in, prerequisite a booking has been made in advance and the group will be cared by accompanier/s during the flight. There is no prerequisite for the number of the accompaniers.

➤ **Non Standard Groups**

- Unusual groups, excessive weights, or anything outside the standard need to be communicated with Corendon Airlines Ground Operations Department (i.e. sports teams with higher passenger weights). The figures should be decided after a specific assessment by our Flight/Ground Ops Departments.

➤ **SSR Report after check-in (PIL)**

- SSR (Special Services Request) Form (PIL) is mandatory for each flight and shall always be issued by the boarding station manually or electronically via DCS, informing the crew of all boarding passengers who may require special attention/treatment on board. Such as the following:
  - The name and seat number of the following passengers shall be shown in the SSR Report
  - Deportees (DEPA & DEPU)
  - Unaccompanied minors (UM)
  - Blind passenger / Guide dogs (BLND)
  - Deaf passengers (DEAF)
  - Deaf and Mute passengers (DEAF/MUTE)
  - Passengers to be carried on stretcher (STRC/BED)
  - Disabled passenger (WCHR/WCHS/WCHC)
  - Passengers requiring a special meals DBML, KSML, NSML, VGML, SFML, SPML
  - Passengers with pets (PETC/AVIH)
  - In case of a delay, information on action performed shall also be stated on the SSR Report.

➤ **Seating at Emergency Exit Rows**

- Passengers who may best assist and not hinder a possibly evacuation from the aircraft should be seated adjacent to an emergency exit. Those who could impede the crew in their duties, obstruct access to emergency equipment or impede the emergency evacuation of the aircraft should not be seated at emergency exit rows.
- Emergency exit rows must not be allocated to:
  - i. Person with reduced mobility, with an intellectual deviancy, elderly passengers, illness or any other form of disability
  - ii. Physical or mentally handicapped passenger unable to move quickly if asked to
  - iii. Person with eye-or-ear defect up to the extent that they might not readily become aware of instructions given to begin an emergency evacuation
  - iv. Pregnant women
  - v. Unaccompanied minors
  - vi. Passengers traveling with infants and/or children under the age of sixteen years
  - vii. Person whose age / physical size (who need extension belt) would prevent them from being able to move quickly
  - viii. Deported passengers / INAD and passengers in custody
  - ix. Persons with guide dogs or pets
  - x. Passengers under the age of 16 years old
  - xi. Passengers benefiting from the Meet & Assist service (MAAS)
  - xii. Sick and injured passengers
- All emergency exit rows are marked on the respective seating/boarding cards and sticker sheets.

**2.3.6 Maximum SCP numbers on B737/800/8**

UMNR	4 pax
WCHR/WCHS	depending on number of ABP's on board
WCHC/MEDA (unescorted)	4 pax
PETC	4 only dogs or cats (2 small pet may be in same cage)
SVAN	4 pax (included PETC)
DEPU / DEPA	PIC decision
Passengers in custody are to be carried on board	1 pax and with 2 escort
INAD	PIC decision
DEAF/BLIND/MUTE/DEAF and MUTE (unescorted)	depending on number of ABP's on board
DPNA	ONLY WITH ESCORT
if the pax DEAF and BLIND	1 pax - ONLY WITH ESCORT
STCH	1
DPNA/MEDA and/or WCHC + UNMR combined should not exceed 4 pax	

**2.4 PASSENGER SECURITY**

**2.4.1. Security of Documents**

➤ **Boarding Passes, Transit Cards and Baggage Tags**

All materials used for passenger and hold baggage processing (e.g. boarding cards, baggage tags, FIMs, vouchers, stamps) must be protected or be under surveillance at all times in order to prevent unauthorized access and use

➤ **Disposal of Printed Documents**

Printed material such as boarding passes, passenger lists, and handling forms may have to be reprinted and are therefore left behind as waste. Dispose of these documents according to data protection rules, as they contain passenger data.

➤ **Information Security**

Departure control systems (check-in systems) must be controlled to prevent unauthorized access.

(a) Follow airport procedures intended to prevent unauthorized use and access to un-issued (blank) boarding passes.

(b) Before leaving the counter, remove boarding cards and baggage tags from the respective printers or lock them.

(c) Before leaving the counter, sign-out, log-off and lock the system.

(d) Observe regulations concerning the usage of sign-ins and passwords.

➤ **Restricted Areas**

Secure all gate and departure areas by keeping doors closed, use appropriate barricades when directing passengers.

Ensure all access doors are closed when not in use.

i. Position staff as required to direct passengers.

ii. If passengers have to walk on the apron to aircraft, ensure passengers proceed directly to the aircraft.

- iii. If transportation has to be provided to passengers to move them from the terminal building to the aircraft, make sure only authorized personnel and screened passengers are allowed to board the vehicle.

➤ **Passenger Suitability for Travel**

Assess each passenger in terms of security risk by looking for anomalies and observing certain emotional characteristics and/or body language. Be on the lookout for overall fitness to fly, including potentially contagious diseases, medical conditions, intoxication, etc.

Further questioning may be required to assist with passenger assessment.

- i. When you identify a potential problem passenger, notify your supervisor.
- ii. The supervisor will contact the appropriate local authority for assistance.

#### **2.4.2. Potentially Threatening Passengers**

Potentially disruptive passengers could jeopardize aviation security during the flight (commit an unlawful act) and safety of the flight, therefore aviation security screening and transportation procedures must be carried out with particular care in respect of them. The relevant Competent Authority/entity planning to embark a person in lawful custody, deportee or inadmissible person on board of the aircraft must notify the AIRLINE as soon in advance as possible. Each embarkation of Person in Lawful Custody and/or Deportee is confirmed by the Aviation Security Manager. Each embarkation of Inadmissible Persons is confirmed by the PIC, in such cases PIC or OCC must notify the Aviation Security Manager. Transportation of a Potentially Disruptive Passengers is prohibited without consent of the Corendon Airlines. Company or PIC may refuse to transport a Potentially Disruptive Passenger on board of an aircraft, when reasonable concerns relating to the safety and/or security of the flight exists.

Potentially Threatening passengers are divided into 3 groups;

- INAD – person not allowed to enter a country,
- DEPORTEE – person ordered to leave a country,
- Persons who have been subjected to legal proceedings.

Before acceptance of Potentially Threatening Passengers, risk assessment must be carried out by the authorities for each passenger intended for removal. The result should be notified to the Corendon Airlines Security Department via fax or e-mail. Also they can inform to aircraft commander directly. The assessment should take account of the passenger's history, previous and current behavior, media and/or activist activity and any other relevant factor which may indicate a security risk. In addition, the following information is provided to operators for risk assessment.

- Name and sex of the person identified as the deportee; reason for deportation (nature of crime);
- Willingness or unwillingness to travel by air;
- Whether the person has attempted to escape custody;
- Whether the person has any history of violence;
- Whether the person has a history of self-harm;
- Whether members of the person's family are booked on the same flight;
- Whether the person is likely to be the target of harm during the transportation;
- Identity of escorts (if required);
- The mental and/or physical state of the person;
- Wanted status of the person (by any other authority);
- Other information that would allow an operator to assess the risk of endangering the security of the flight;

- Special conditions and precautions for transport of the person, if any.

After authority’s risk assessment, Corendon Airlines evaluate the situation and make own risk assessment for acceptance or rejection. Corendon Airlines is categorized the risk assessment as Low Risk Level and High Risk Level.

Category	Low Risk	High Risk
INAD Passengers	Passenger Behavior is not threat for flight	Potential aggressive passengers who effect the flight security During the Flight. If escort needed.
	Documentation Problem	
	Financial Problem	
	Suspicious Profile	
Deportee	DEPU	All DEPA passengers
Persons Who Have Been Subjected to Legal Proceedings	-	For all passenger

Corendon Airlines does not carry any High Risk passengers except their own passengers. If Corendon Airlines have to carry High risk passengers, the information must be shared minimum 72 hours prior of departure time. Aviation Security Manager, Chief Operating Officer and Chief Flight Operations Officer evaluate the risk and inform to mentioned flight’s captain. After confirmation of responsible captain, the passengers can be accepted. After confirmation of passenger, escorts’ information (name, seats, number etc.) have to be shared.

Also during flight, the flight crew have to contact with escorts instead of passenger for all issues.

**Note:** Normal handling procedures are applied for Low Risk Passengers.

After acceptance of the Potentially Threatening Passengers the Handling Agent must inform the PIC and Cabin Chief such as Potentially Threatening Passengers prior to passenger embarkation via **Potential Threatening Passenger Information Form**.

Also the filled form shall be sent to [guvenlikD@corendon-airlines.com](mailto:guvenlikD@corendon-airlines.com) and [groundoperations@corendonairlines.com](mailto:groundoperations@corendonairlines.com). The Potential Threatening Passenger Form is published on Digital Library and <http://handling.corendonairlines.com>

The Pilot in Command has total responsibility to decide how many INAD, DEPORTEE and Passengers subjected to legal proceedings are to be carried on board, in accordance with safety and security issues.

Detailed information related to these passengers shall be given to destination airport. If the related airport authority requests additional measures, Corendon Airlines will apply these measures. If available, escorts information will be given to destination airport.

**2.4.2.1 Inadmissible Passenger**

INAD passengers (inadmissible passenger) are those persons who are unable to enter a country due to visa problems, invalid passport, lost passport etc.

Airline companies are obliged to fly their own INAD passengers back there their country as soon as possible. This period cannot be more than 48 hours.

As Company Policy, if the Captain feels that the INAD belonging to another airline company may endanger the flight, he/she is entitled to request for an escort from the authority or may refuse to carry of such passenger.

- **Handling Procedure**

- The handling agent must inform the Captain and Cabin Chief about the INAD passenger prior to passenger embarkation,

- ii. The INAD Form prepared by the authority and if available the passenger's passport is given to the PIC and/or Cabin Chief. If necessary, the documents may be kept in the flight deck during flight, but they shall never be returned to the INAD passenger,
- iii. INAD's shall be boarded prior to other passengers and be the last to disembark at the destination. Their documents are handed over to the authority and are escorted out from the aircraft,
- iv. INAD passengers should be seated at the back section of the A/C, at a window seat,
- v. They shall not be served alcohol.
- vi. If an official has been requested to escort the INAD, the INAD shall be seated at a window seat and cabin crew shall perform meal and services as directed by the official.
- vii. Mentally disabled and persons considered a threat to flight safety shall be accompanied to the aircraft by someone who can use a sedative if needed.
- viii. If a mentally disabled passenger requires a sedative before the aircraft takes off the sedative must be used for it to last for the entirety of the flight.

#### 2.4.2.2 Deportee Passengers

Deportees are persons who are caught by the authorities and are ordered to leave the country because of their legally or illegal entrance; e.g. persons remaining to stay in the country with an expired visa, persons who have been detected with a forged passport.

Deportees are not persons who have committed a murder or serious offense.

If the Captain feels that the deportee may endanger the flight, he/she is entitled to request for an escort from the authority or may refuse to carry the passenger.

##### ➤ Handling Procedure

- The Deportee Form prepared by the authority and if available the passenger's passport is given to the CC. If necessary, the documents may be kept in the flight deck during flight, but they shall never be returned to the DEPORTEE passenger
  - DEPORTEE's shall be boarded prior to other passengers and be the last to disembark at the destination. Their documents are handed over to the authority and are escorted out from the aircraft
  - DEPORTEE passengers shall be seated at the back section of the A/C, at a window seat,
  - They shall not be served alcohol.
  - If an official has been requested to escort the DEPA, the DEPORTEE shall be seated at a window seat and cabin crew shall perform meal and services as directed by the official
- **DEPA** refers to the industry-approved code for a deportee who is escorted by authorized personnel during flight.
- **DEPU** refers to the industry-approved code for a deportee who is not escorted by authorized personnel during flight.
- On written request by the competent authority, Corendon Airlines may transport deportees. This written request must be submitted in sufficient time, containing the following details:
    - i. planned routing;
    - ii. identity of the person;
    - iii. reason for transportation;
    - iv. name and title of escort(s), if provided;
    - v. risk assessment by the competent authority (including reasons for being accompanied by guards (DEPA) or not being accompanied by guards (DEPU));
    - vi. Special seat arrangement, if necessary; and
    - vii. Nature of available document(s).

- There is no limit for the numbers of Deportee to be carried. It is up to the PIC according to received information by ground Personnel. A notification must be given to the flight and cabin crew to ensure the implementation of the following additional security measures:
  - i. stringent screening of the individuals and their cabin and hold baggage;
  - ii. boarding prior to all other passengers, subject to coordination with the Commander;
  - iii. deportees shall not be seated next to or directly across from any door or exit, or in any aisle seat;
  - iv. alcoholic beverages shall not be served;
  - v. sufficient guards if deemed necessary according to the risk assessment;
  - vi. guards shall be able to communicate with the aircraft crew;
  - vii. no public disclosure about the transportation of potentially disruptive passengers;
  - viii. Restraining devices shall be provided, if deemed necessary in the risk assessment.

#### **2.4.2.3 Persons Who Have Been Subjected to Legal Proceedings**

Suspects, detainees and convicted persons are those passengers who are potentially dangerous. These passengers are accepted on flights, provided that they are escorted by at least 2 escorts. In the case of more than one person who has been subjected to legal proceedings considered that he/she is dangerous, only 1 is accepted on board. Corendon Airlines must be informed about such passengers prior to flight. However, the Captain may choose to refuse to carry such passenger as company policy.

#### **Handling Procedure**

- Public announcements about the carriage of such passengers shall not be made,
- The Handling Agent must inform the Captain and Cabin Chief about the passenger prior to passenger embarkation,
- The Form prepared by the authority and if available the passenger's passport is given to the Cabin Chief. If necessary, the documents may be kept in the flight deck during flight,
- The passenger shall be boarded prior to other passengers and be the last to disembark at the destination,
- The passenger is to be seated between the two escorts at the back seats of the A/C, metal forks and knives are not given.
- While going and coming back from toilet, he or she is kept under surveillance.
- The escorts shall remain in communication with the cabin crew and they will prevent the transport of prohibited substances like matches, lighters by persons who have been subjected to legal proceedings.
- The escorts shall have physical strength and equipment to render harmless persons who have been subjected to legal proceedings when deemed necessary,
- The escorts cannot use tear gas in the aircraft or gas and other substances which leaves weak persons who have been subjected to legal proceeding.
- They shall not be served alcohol and cabin crew shall perform meal and services as directed by the officials,
- If necessary, restraints (plastic handcuffs) found in the A/C may be used.
- If escorts will carry firearms, Corendon Airlines must be informed one day before the flight. Corendon Airlines has right to refuse carry escorts with firearms.
- Convicts who may use allowed under the provision of Regulation is not covered by this article. They may travel with "Photo Permit" without an escort.
- Prisoners, convicts, suspects, those under legal proceeding and those deported from the country, etc. accompanying law enforcement officers can take their weapons to the aircraft cabin if there is a

phrase, text, form or similar material related to the necessity of carrying weapons during their escort duty.

- However, the companion must be taken magazine from the gun in a safe area and it must be ensured that the gun is free from bullets. The weapon 'or magazine or both (must be acted according to the airline application) is delivered to the pilot from the responsible captain to be stored in the secure box in the cockpit
- In such flights, the airline company must be informed as much as possible (e.g. at the time of booking) in order to fulfill its responsibility for secure box transportation.
- If the companions are not allowed to carry weapons in the cabin, the airline may decide to carry the weapons in the cabin or to carry them hold compartment in accordance with their own policies.

#### **2.4.2.4 Passengers Who Decide No to Fly or Passengers Board to the Wrong Aircraft**

In the event that any person, who has been admitted as passenger and already undergone security checks, willingly decides not to fly at the last minute, disembarks the aircraft, or embarks the wrong aircraft, and this mistake is discovered, additional security measures shall be applied.

In the event that the passenger reverses his/her decision upon being informed on the security actions to be taken when she/he disembarks, and that the local applications may differ, the cabin crew shall not take any action. In case of the passenger boarding the wrong aircraft or decided to not to fly;

- The passenger shall be ensured to disembark along with the carry-on baggage.
- The hold baggage of the passenger, if any, is also offloaded.
- Baggage ID announcements are made to passengers on board.
- Passengers shall be provided to take on passenger's lap and show all personal belongings they have taken into the aircraft, and it shall be determined whether they have taken any baggage/packages or bags to be carried on that aircraft from another passenger whom they do not recognize and a security search is made inside the aircraft so as to cover everywhere likely to be accessed by the passenger who boarded the wrong aircraft or has refused to fly.

#### **2.4.2.5 Right to Refuse of Carriage Passenger**

Corendon Airlines may decide to refuse to carry a passenger or his/her baggage if, in the exercise of Corendon Airlines' reasonable discretion, Corendon Airlines considers that one or more of the followings have occurred or Corendon Airlines believes, may occur:

- Refusal to carry is necessary in order to comply with any applicable legislations including laws, regulations, or orders and etc.; or
- A passenger commits, or has committed a misdemeanor or a criminal offence during any of the operations of embarkation on his/her flight, or disembarkation from a connecting flight, or on board the aircraft whether in connection with his/her current flight or a previous unconnected flight, whether with Corendon Airlines or on board another carrier; or
- A passenger fails, or has failed to obey or observe safety or security instructions of, or obstruct or hinder, ground staff, aircraft crew members or security personnel in the performance of their duty; or
- A passenger uses, or has used, threatening, abusive, or insulting words or behaves, or has behaved, in a threatening, abusive, insulting or disorderly manner to security personnel, ground staff or aircraft crew members prior to or during boarding/leaving the aircraft or
- A passenger has intimidated or deliberately interfered with security personnel or with Corendon Airlines personnel or an aircraft crew member carrying out their duties on board an aircraft on the ground or in flight; or
- A passenger has sat in a seat not assigned to him/her and refused the request of Corendon Airlines' staff or cabin crew member to move to his/her assigned seat; or

- The carriage of a passenger or his/her baggage may endanger or affect, or has endangered or affected, the safety of the aircraft or anyone in the aircraft; or
- The carriage of a passenger and/or his/her baggage may endanger or affect the safety or health of other passengers or aircraft crew members; or
- The carriage of a passenger or his/her unchecked baggage may materially affect the comfort of other passengers; or
- A passenger's mental or physical state, including his/her impairment from alcohol or drugs, appears to present a hazard or risk to himself/herself, to passengers, to aircraft crew members, to the aircraft or any person or property in it or represents a likely source of material annoyance or discomfort to other passengers; or
- A passenger has put the safety or security of the aircraft or any person in it in danger; or
- A passenger has refused to submit himself/herself or his/her baggage to a security check or to comply with the requests or directions of security personnel; or
- A passenger fails, or has failed, to observe our instructions with respect to safety or security and comfort of other Passengers on matters such as, but not limited to, seating, the fastening of safety belts, storage of unchecked baggage, smoking, consumption of alcohol or use of drugs, use of electronic equipment including, but not limited to mobile/ cellular phones, laptop computers, PDAs, portable recorder, portable radios, CD, DVD and MP3 players, electronic games or transmitting devices; or
- A passenger is, or Corendon Airlines reasonably suspects that he/she is, in the unlawful possession of drugs; or
- A passenger has made a hoax bomb or hijack threat; or
- A passenger has not paid the applicable fare, taxes, fees, charges or surcharges; or
- A passenger has failed to provide satisfactory positive identification documents including recent photographs or he/she has failed to cooperate with Corendon Airlines in the use of biometrics.
- A passenger does not have, or does not appear to have, valid travel documents, may seek to enter a country through which he/she may be in transit, or for which he/she does not have valid travel documents, destroy his/her travel documents during or after flight or have refused to allow Corendon Airlines to copy his/her travel documents or refuse to surrender his/her travel documents to the aircraft crew members, when so requested; or
- A passenger does not appear to be able to meet requisite visa requirements in relation to any country through which he/she may be in transit or into which he/she may seek entry; or
- Corendon Airlines has been informed by the immigration or other authorities of the country to which he/she is travelling, or for a country in which he/she has a stopover planned, that he/she will not be permitted entry to such country even if he/she has valid travel documents; or
- A passenger has failed to give Corendon Airlines information in his/her possession which a governmental authority has lawfully asked Corendon Airlines to give about him/her; or
- A passenger has not presented a valid ticket or he/she presents a ticket that has been or appears to have been acquired unlawfully, has been purchased from an entity other than Corendon Airlines or its authorized agent, or has been reported as being mutilated, lost or stolen, is a counterfeit, or he/she cannot prove that he/she is the person named in the ticket; or
- A passenger has failed to comply with the requirements set forth in the ticket and use, or he/she presents a ticket which has been issued or altered in any way, other than by Corendon Airlines or its authorized agent, or the ticket is mutilated; or
- He/she has not presented a valid ticket or his/her boarding pass or his/her identity card, travel documents or visa when reasonably requested to do so; or
- A passenger has failed to complete the check-in process by the check-in deadline or he/ she has failed to arrive at the boarding gate at the time specified by Corendon Airlines when he/she checked-in; or
- Corendon Airlines has notified a passenger in writing that it would not at any time after the date of such notice carry him/her on its flights; or

- A passenger does not appear, and cannot reasonably satisfy Corendon Airlines otherwise, that he/she is medically fit to fly, or
- He/she or someone who is legally responsible for him/her if he/she is a minor, has failed to comply with the requirements of Corendon Airlines; or
- He/she, or someone for whom he/she is responsible travelling with him/her (such as, but not limited to, a minor) is not permitted by law or court order from leaving the jurisdiction of the place of departure of the aircraft; or
- He/she failed to disclose any item to Corendon Airlines or contracted ground personnel that he/she has included in his/her baggage; or
- A passenger has deliberately damaged or unlawfully removed any of Corendon Airlines' equipment or property including in-flight entertainment equipment, and etc.; or
- By word or by behavior, a passenger has been unduly aggressive, intimidating, threatening, abusive or insulting, including behavior which may be described as sexual harassment, towards other passengers; or
- By word or by behavior, a passenger has behaved in a manner to which other passengers may reasonably object or have objected or his/her behavior is likely to cause discomfort or unnecessary inconvenience to other passengers; or
- A passenger has previously committed one of the misdemeanors or acts or omissions referred to above or on a previous flight committed misconduct of the type referred to above; or
- Corendon Airlines has been notified or Corendon Airlines has good reason to believe that a passenger has previously committed one of the misdemeanors, acts or omissions referred to in these conditions prior to or while boarding or disembarking or during flight on board the aircraft of another carrier.
- Acceptance for carriage of unaccompanied children, incapacitated persons, pregnant women or persons with illness may be subject to prior arrangement with Corendon Airlines, in accordance with Corendon Airlines' regulations and rules.
- Physically impaired person that required a wheelchair or has an orthopedic or implanted electronic device who refuse to undergo screening before boarding or entering an aircraft will be denied from boarding and will not be allowed to pass the point of search.
- In case of refusal passenger including security issues, handling company shall fill out "The Passenger Irregularity Form "and sends to [guvenlikD@corendon-airlines.com](mailto:guvenlikD@corendon-airlines.com) and [groundoperations@corendon-airlines.com](mailto:groundoperations@corendon-airlines.com) .
- Persons who refuse to undergo screening before boarding or entering an aircraft are denied boarding and not allowed to pass the point of search.

#### **2.4.3. Procedures for Unruly Passengers**

- Passengers who behave in an unruly and disruptive manner on aircraft in flight are an ongoing concern for all airlines. The disruption of the good order of a flight impacts on the well-being of passengers, interferes with crew performance and can threaten the safety of a flight. The classification of "unruly and disruptive behavior" in flight or on ground covers a range of conduct and includes:
  - Acts which violate the criminal laws of a State
  - Acts, although not offences that violate the criminal law, may or do jeopardize the safety of an aircraft, crew, passengers or property therein;
  - Acts which jeopardize good order and discipline on board or on ground.
- Corendon Airlines has in place procedures to both prevent and control unruly passengers. Crew and ground staff receive specific training relating to dealing with these types of passengers.
- For more information, please see National Civil Aviation Security Program and SHY-IPC

➤ **Procedures on the Ground for Unruly Passengers**

- Several possibilities exist for staff to recognize the potential troublemaker. These include check-in, the lounges and the boarding gate. If the passenger is considered a trouble maker, then the flight crew should be informed, so they can be proportions.
- As a policy, CAI has right to refuse unruly passengers at check-in and upon discovery after check-in, when deemed necessary according to procedures below.
  - i. Initial action to refuse carriage will normally be taken by the GOP supervisor on duty or the senior staff member present who must exercise discretion:
  - ii. If the passenger carries on causing problems and uses violence then he/she will not be allowed on the aircraft.
  - iii. The ground management and the PIC must decide if the passenger is to board the aircraft or not.
  - iv. If the passenger is not allowed on board inform the security immediately and write a report.
  - v. Confer with the commander and cabin chief to decide on the appropriate course of action if allowing the passenger to travel is being considered and inform security accordingly.
  - vi. GOP supervisors have clear guidelines on the correct procedure to be followed when this course of action is considered appropriate.
- Once a passenger has been identified as a potential troublemaker, and the decision is made not to refuse carriage, chief cabin crew must be informed so that special attention can be given.
- Passengers who present themselves at the check-in counter under the influence of alcohol or drugs or who display aggressive behavior, shall not be accepted for flight.
- Care must be given in assessments of such situations and professional help called (security) if necessary. When in doubt, passengers must be checked in on a standby basis, and their baggage not loaded on the aircraft to avoid a delay when it is decided that they will not be accepted (by local authorities or by the commander).
- If passengers are not allowed to check in, they should be referred to the tour operator who issued their ticket.
- However, passengers may not always display such behavior at check in. If it becomes clear at boarding that it is unsafe to accept passengers for transport, they must be denied boarding, their baggage must be offloaded and flight coupons must be clearly marked 'Unruly passenger – denied boarding – safety measure'. They should then be referred to the tour operator who issued their ticket.
- In all cases, the commander of the flight as well as AYT Ground Operations shall be notified that passengers have been denied check-in or boarding, with written mention of passenger names and tour operator.

➤ **Procedures in the Air and Related Reporting Procedures**

- For unruly passenger procedures in-flight please refer to CCM chapter 10.09 .

➤ **Assault by Passengers on Crew Members**

- In the event that a passenger has physically or verbally assaulted a crew member, the same actions can be taken as handling procedures for unruly passengers by chief cabin crew and/or commander. Cabin Chief or PIC should make a report via **SERA Reporting System**.
- For Sample warnings and for more information see Corendon Airlines Security Manual.

#### 2.4.4. Acceptance of liquids in cabin

- Please check [http://ec.europa.eu/transport/modes/air/security/aviation-security-policy/lags\\_en.htm](http://ec.europa.eu/transport/modes/air/security/aviation-security-policy/lags_en.htm) for liquid restrictions.

**➤ Medicines**

Essential medicines and baby foods may be permitted in larger quantities above the 100 ml limit, but will be subject to the authentication that is already currently required. Cabin baggage and size allowed. Each passenger is restricted to carrying only one item (in addition to the re-sealable liquids bag) through the airport search point. Pushchairs, walking aids and wheelchairs are permitted but will be screened.

**2.5 PASSENGER IRREGULARITIES**

- Delays inevitably cause inconveniences. Corendon Airlines will take the upmost care and attention prevent delays and irregularities. Some of these are visible to passengers, such as passenger information and passenger welfare, and others less visible such as communication and coordination.

**2.5.1. Information to Passenger**

- When required due to airport peculiarities and once check-in has been completed, passengers must be informed on the way to reach the proper gate and also if needed Customs Inspection and Passport
- Control and on the Security measures before boarding aircraft, delays and any other appropriate information.
- The handling agents of EU countries are required to display, at check-in, a clearly legible notice as follows, in a manner clearly visible to passengers:
- A text of "If you are denied boarding or if your flight is cancelled or delayed for at least two hours, ask at the check-in counter or boarding gate for the text stating your rights, particularly with regard to compensation and assistance".
- In case of denied boarding, flight cancellation or a delay of more than 2 hours, each passenger shall be provided with a written notice setting out the rules for compensation and assistance. This notice must be given to the passenger after a delay of 2 hours.
- The handling agent will use the relevant Corendon Airlines notices and forms mentioned above in "b" and "c", when provided. These forms and notices shall include the contacts of the Complaints Management Department.
- The handling agents are required to demand 'Air Passenger Rights' leaflets and placards from Corendon Airlines 2 weeks before they run out.
- By purchasing passenger tickets, passengers must accept the terms and conditions laid down in our conditions of carriage which is on the internet web site. These terms and conditions are subject to change at the discretion of Corendon Airlines without prior notice to the passengers. Corendon Airlines operations and flights are conducted in compliance with relevant national and international regulations. Should there be any conflicts between these regulations and the sales conditions defined there, the relevant national/international regulations apply.
- Corendon Airlines may charge a fuel surcharge from the passengers in addition to their flight ticket price to compensate fuel price changes in the global market.
- Even if the passenger has bought a ticket for a Corendon Airlines flight, Corendon Airlines is entitled to operate that flight through another air carrier.
- Timely, accurate and truthful information is the single most important aspect of handling a delayed flight.
  - i. Passengers must be kept informed regularly and completely;
  - ii. If the probable length of a delay is unknown, then passengers are to be told;
  - iii. In announcements passengers are to be informed of any updates and additional information in 30 minute intervals and repeat these updates if necessary;
  - iv. Do not delay in making an announcement until you have something definite to tell them;
  - v. Do not hesitate contact with passengers;

- If no monitors are available, an information sheet should be visible at the check-in counter, to provide sufficient and correct information to passengers; As soon as a delay becomes apparent - and throughout a delay situation - inform Antalya (AYT) Ground Operations.
- In theory, passenger welfare is the responsibility of the airline. In practice, it concerns all parties involved in airport operations, and tour operator representatives can provide assistance, from providing vouchers to arranging coach transfers or diverting passengers to hotel accommodation instead of bringing them to the airport.
- Because of EU legislation regarding Denied Boarding Compensation (DBC), the handling agents of EU countries are required to display, at check-in, a clearly legible notice as follows, in a manner clearly visible to passengers.
- Delayed flights after 15 minutes must report to Ground Operations with delay codes by mail. For Delays over 15 minutes, the handling agent or representative shall fill in the CA-GOP-HIR and forward it to AYT Ground Operations.
- You may find the HIR report at the Chapter 10 – Forms – (please ask the sample form from [groundoperations@corendon-airlines.com](mailto:groundoperations@corendon-airlines.com))
- You may find the air passenger rights letters in <https://handling.corendonairlines.com>
- In case of a delay, action taken must be confirmed by AYT Ground Operations who is expected to get in contact with the representative of the relevant tour operator.

**2.5.2. Services provided to passengers in case of Delays, Cancellations and Other Irregularities**

- In case of denied boarding, flight cancellation or a delay of more than 2 hours, each passenger shall be provided with a written notice setting out the rules for compensation and assistance. This notice has to be given to the passenger after a delay of 2 hours and shall include the contacts of Corendon Complaints Management department.
- In case of a delay, the action to be taken shall be as follows upon confirmation by Ground Operations Department who is expected to contact the representative of the relevant tour operator. The following procedures shall be applied on flights departing from an EU country:

Duration for the delay	Type of service to each passenger
Between 2 and 3 hours	Snack or meal & hot/cold drinks and two free telephone calls, telex or fax messages, or e-mails should be provided to the passengers.
Between 3 and 5 hours	Depending on the time of day, breakfast or meal & hot/cold drinks and two free telephone calls, telex or fax messages, or e-mails should be provided to the passengers.
5 hours and more	Depending on the time of day, breakfast or meal & hot/cold drinks, additional hot and cold drinks and additional light snack and two free telephone calls, telex or fax messages, or e-mails should be provided to the passengers. *If the duration of the delay makes hotel accommodation necessary, corresponding information will be given by the OCC. This will be done in full co-ordination with the tour operator’s headquarters and/or its local representative.
Accommodation to the passengers	Accommodation is provided for delays of 6 hours or more between 20:00 p.m. and 07:00 a.m. Transportation between the airport and the accommodation (hotel or similar).
Denied boarding, over sale, flight cancellation	The representative of the tour operator should be contacted to transport the passenger to the destination. For each case, instructions from Ground Operations Department shall be followed.

- All cost shall be entered on the Ground Handling Charge Note for settlement by Corendon Airlines HIR shall be filed out in case of irregularity or major delay and sent to Corendon GROUND OPERATIONS department. The voucher value should be discussed with Corendon GROUND OPERATION department.
- In case of overbooked and denied boarding, The Passenger Irregularity Form shall be filled and sent to [groundoperations@corendon-airlines.com](mailto:groundoperations@corendon-airlines.com).
- In case of delays, flight cancellation and any flight irregularities, the Delay Irregularity Form shall be filled and sent to [groundoperations@corendon-airlines.com](mailto:groundoperations@corendon-airlines.com)
- The above mentioned forms are stored in our intranet page <https://handling.corendonairlines.com/handling/tr/Login>

### 2.5.3. Sick, unacceptable or Handicapped Passenger

- As a policy, transport of sick / invalid passengers will only be granted if the passenger is in possession of a written fitness report issued by his doctor or an official medical agent at the airport.
- Each individual request must be approved by Corendon Airlines SITA Addresses (AYTOP7H)
- All incidents must be report to Ground Operations by filling HIR
- The passenger name will be included in the passenger-booking message to all stations concerned; the same procedure applies for cases of passengers in stretchers.
- Invalid or sick passengers including users of wheelchairs requiring any assistance at transit or disembarkation stations must be advised by SITA to the handling agent of respective station (Passenger Service Message) PSM.
- The station is fully responsible for checking the fitness report for the transportation of sick, unacceptable passengers.
- Sick, unacceptable/ handicapped passenger shall not occupy seats where they impede the crew in their duties, obstruct access to emergency equipment or impede the emergency evacuation.
- The Ground Operations Department will advise the handling agents and airports, if different procedures are to be followed.
- If passengers do not declare their illness before flight, they will fly at their own risk and responsibility.
- **No transportation under any circumstances, will be provided to a person who:**
  - i. Passengers have a contagious/infectious disease, e.g. open tuberculosis, infectious hepatitis, scarlet fever, diphtheria, chickenpox, etc. shall not be accepted without a medical certificate signed by an independent medical doctor.
  - ii. Has suffered a heart attack or stroke within the last eight weeks
  - iii. Requires medical attention by pneumatic or electrically operated apparatus which, for specific reasons, is not allowed on board
  - iv. Any person who requires an oxygen bottle operated apparatus together with oxygen supply during the flight).
  - v. Any person under the influence of drugs and alcohol. To extend that the safety of the flight to be endangered.
  - vi. "Unacceptable" All persons whose carriage by air acceptance for carriage is subject to a verification and confirmation of their fitness to travel by air, by a doctor.
  - vii. "Handicapped" All incapacitated passengers who are not "invalid" and whose carriage is not subject to verification and confirmation by a doctor
  - viii. Handicapped passengers should ONLY be seated in seats A and F. However, the below mentioned rows/seats shall NOT be allocated at all to handicapped persons: B737-800: ROW 16 & 17
  - ix. The following definitions of ECAC Doc 30 constitute agreed indications of mobility and extend of the assistance required.

#### 2.5.4 Passengers Not Requiring a Medical Clearance

Medical document, materials and equipment are not required for passengers who only require special assistance in the airport, or in embarking/disembarking.

- LEGL: passenger with broken or injured left leg and can bend left leg at the knee.
- LEGR: passenger with broken or injured right leg and can bend right leg at the knee.
- BLND
- DEAF
- WCHC
- WCHR
- WCHS
- WCMP Manual powered wheelchair of the passenger
- WCBD Dry battery powered wheelchair of the passenger (Dry Cell Battery)
- WCBW Wet battery powered wheelchair of the passenger Wet Cell Battery
- WCLB Lithium battery powered wheelchair of the passenger (Lithium Battery)

#### Acceptance of sick passenger during check-in/boarding:

In case if during check-in or boarding process any doubts are cast upon passenger health conditions handling staff should inform:

- CORENDON representative or CORENDON Ground Operation department.
- Airport doctor

#### 2.5.5 Plaster Cast

- A medical report is required for the flights, if the implementation of plaster cast has been done less than in 48 hours at the time of departure and the cast is not bivalve.
- The medical report is demanded from the airport doctor or the doctor who continues the passenger's treatment, for capability of traveling stating that "The passenger is in a condition to travel by air". And the medical report must be in English.
- The date of plaster cast should be stated in the medical report.
- If the plaster is casted more than 48 hours prior to the departure time, the passenger will be accepted for the flight with an indemnity form.

### 2.6 BAGGAGE HANDLING PROCEDURES

#### 2.6.1. Cabin Baggage

- Cabin baggage is a kind of baggage that is carried and stowed in the cabin under the passengers control and custody. It is commonly referred to as carry-on baggage or unchecked baggage.
- Cabin Baggage must be restricted to one piece per passenger occupying one seat (infants are not allowed to carry cabin baggage) and he/she is responsible for such baggage. The conditions under which these pieces are accepted in the cabin are as follows:
  - Maximum Weight : 10 kg
  - Maximum Dimensions : 55 \* 40 \* 25cm
- Cabin baggage cannot be accepted if it:
  - is unsuitable for air carriage due to its weight, size or nature;
  - cannot fit under the seat or be stowed in the overhead compartment;
  - is unsuitably packed
  - Passenger should pay **75€** penalty fee if he/she hide his/her additional cabin bag and/or oversize cabin bag.
- Restrictions:

- certain items, because of their weight, size or nature are only accepted with the consent of the operator;
- for security reasons, many countries restrict the carriage of liquids, aerosols and gels in hand baggage;
- items refused by security screening must be hold-checked as per the Corendon Airlines's policy.



*According to IATA Dangerous Goods Regulations (DGR), certain items are prohibited in checked baggage, e.g. cigarette lighters, matches, spare lithium batteries. Handling Agent must be aware of commonly carried dangerous goods items and ask the passenger of these being carried. Please see chapter 8 of this manual for more information related to DGR.*

### ➤ Procedure at Check-In:

- Assess the size, weight and intended number of pieces of carry-on baggage to meet the Corendon Airlines's standards.
- Weigh all carry-on bags,
- Refer the passenger to the baggage sizer, if available.
- Attached an "cabin bag tag" tag.
- If the carry-on baggage exceeds the free allowance size and/or weight, it must be hold-checked, and must be charged.
- When a passenger wishes to carry any kind of electronic equipment as cabin baggage e.g. a television, radio receiver, etc, they shall be advised at check-in that the use of such equipment is prohibited onboard the aircraft. This does not apply to the use of tape recorders, dictaphones, hearing aids or heart pacemakers, provided that no disturbance is caused to other passengers.
- Be aware of dangerous goods that may be commonly carried, but that are not permitted. Ask the passenger if they have any of these items.
- If the passenger is willing the cabin baggage to be checked-in within the required limits, the cabin baggage is accepted as free of charge and inserted into the check-in system. Additionally, if the flight is booked over than 150 passengers, please accept at least 30 cabin baggages for the cargo compartment as free of charge during the check-in phase and inserted into the check-in system as required.

### ➤ Procedure at Boarding:

- Check for items which are unacceptable, oversized, overweight or exceed the number of pieces as free carry-on baggage, using the cabin baggage sizer if applicable.
- Check with the passenger that the baggage contents are in compliance with the IATA Dangerous Goods Regulations (DGR). Have the passenger remove any items specifically prohibited in hold baggage.
- Consider below list as a potential Dangerous Good items and ask the passenger to remove them below their baggage:
  - i. Smartphones, tablet, laptop
  - ii. Cameras
  - iii. Spare lithium batteries
  - iv. Electronic cigarettes,
  - v. Lithium battery operated toys and drones
  - vi. Any other electric device, when in doubt.
- Advise the passenger to remove any personal documents or medications.
- Collect any other cabin baggage that cannot be accommodated on board due to limited storage space.
- Tag bag with manual bag tag or limited release tag to the final destination.
- Account for the baggage tag number(s) and weight into the DCS check-in record or manually.
- Inform the passenger of pick up at the baggage claim area .
- Advise ramp staff and/or Load Control of the gate baggage to be loaded.

- Inform the commander that all Dangerous goods items were removed before sending baggage to cargo hold.

### 2.6.2. Checked Baggage

- Checked baggage is baggage for which the carrier takes custody and issues a baggage check.
- Checked baggage is carried in the hold of the aircraft on which the passenger is travelling.
- Corendon Airlines may refuse to carry checked baggage which is inadequately packed or unsuitable for air carriage due to its weight, size or nature.
- Every piece of baggage must display the passenger's name.
- Certain items, because of their weight, size or nature, are only accepted with consent of the Corendon Airlines.
- Passengers shall be informed that articles such as umbrellas, walking sticks, parcels, etc shall not be attached to checked baggage because they may cause damage.
- The check-in staff must verify that all checked baggage is in good condition, properly packed in suitcases or another type of container and not damaged. If a suitcase appears to be damaged, the passenger will be informed that the baggage is refused due to its condition. If the passenger insists on his baggage being accepted, it may be accepted whenever there is no risk of loss of the content and provided staff seal the suitcase with the label 'baggage damaged before check-in'. This statement will also be entered on the ticket and on the baggage identification tag.

#### ➤ Checked Baggage Allowance:

- Unless otherwise specified, the free baggage allowance per passenger is 20 Kgs excluding cabin baggage for all Corendon Airlines flights. It is also indicated in the passengers' tickets. Infants under 2 years are entitled to a free baggage allowance up to 10 kgs. Personal items may be carried in excess of the baggage limitation on condition that these articles are not packed in the suitcases.
- Passengers departing from or arriving to the airports in the Netherlands and Belgium/Germany (who have bought online an ECO plane ticket) will be charged for hold luggage. This regulation is applicable to package bookings, as well as seat-only customers and departures from/to Netherlands/Belgium/Germany (and not applicable at other airports).
- Please visit [corendonairlines.com](http://corendonairlines.com) for more information about standard luggage regulations.

#### ➤ Excess Baggage Charges:

- Excess Baggage Fees are available in Corendon Airlines internet page. Please visit [corendonairlines.com](http://corendonairlines.com) for excess fees depend on the destinations.
- Excess baggage will only be accepted after payment. Excess baggage rates and coupons can be obtained from the Ground Operations Department. Any excess baggage coupon issued should be sent to and collected fees should be transferred to Corendon Airlines head office Accounting Management either directly or via the Ground Operations Department, together with a list of coupons used.
- Even if a passenger pays for excess baggage, one piece of baggage must not be heavier than 32Kgs.
- A guide dog when accompanying a blind passenger shall be considered a personal item. The weight of other accompanying pets including their cages shall be considered excess baggage even if the passenger does not carry baggage more than the free baggage allowance.

#### ➤ Standard Baggage Check-In:

- Accept checked baggage that is appropriately packaged and labeled with passenger identification.
- Ensure dangerous goods signage is on display.
- Review weight and pieces information for recording in the DCS and for applying appropriate fees.
- If applicable, ask the passenger any required security related questions.
- Agent should be aware of items due to their nature that might contain dangerous goods.
- Unaccompanied baggage is baggage carried on a flight and not accompanied by a passenger. Unaccompanied baggage on Corendon Airlines flights is prohibited.

#### ➤ Baggage Tags:

- All old tags must be removed.

- Apply appropriate destination tag and handling tags.
- Place tags in an easily readable location, and where they will not easily be torn off.
- Follow tag instructions, and do not stick glue directly to passenger baggage.
- Use limited release tags as per Corendon Airlines Policy
- Baggage tags shall be stocked and secured at all times to prevent them from becoming available to unauthorized person and never given to third parties. Ensure that the destination shown on the baggage tag matches with the destination to which the baggage has been checked.
- Follow Corendon Airlines procedures with respect to supplementary tags on baggage items, such as:
  - i. Priority tags—to identify Priority baggage to be offloaded first, and segregated as per carrier. Priority labels should tag on the baggages for the passengers who paid for more leg space seats at check-in or web.
  - ii. Limited Release Tags—used on fragile or unsuitably packaged items. When a bag is presented at check-in and falls into one or more the categories listed below a “Limited Release Label” must be used in place of the normal baggage label and signed by passenger. The categories are;
    - i. Fragile
    - ii. Unsuitably packed
    - iii. Damaged
    - iv. Late check-in (check-in after deadline)
    - v. Not permitted as cabin baggage
    - vi. Baby buggies
    - vii. Golf bags
    - viii. Wheelchairs



*The passenger must be advised of the unsuitability of the item, and that Corendon Airlines may not accept claims resulting from the above conditions of acceptance. The appropriate box on the label should be ticked and if the baggage is damaged before check-in, the damage must be indicated in the diagram on the reverse of the label. Handling agents should send Flight messages after check-in related to the LRT which should show passenger name and tag number to [AYTLL@corendon-airlines.com](mailto:AYTLL@corendon-airlines.com) and AYTLLXC.*

- Fragile Sticker—requires extra care in handling. Please use with Limited Release Tag.
- Heavy Tag—placed on items over 23 kg (50 lb).

### 2.6.3. Special Baggage's

- For special baggage rates please check [corendonairlines.com](http://corendonairlines.com)
- **Oversized Baggage:** Baggage is oversized as defined its weight exceeds 32 kg (70 lbs). Handling agents should be aware of the following:
- **Bicycles:** The use of a cardboard transport box is recommended; Handle bars must be positioned parallel to the frame. Tires must be deflated. Paddles must be removed or mounted facing inwards. Max 6 bicycles can be accepted on flight. Bicycles are acceptable as checked baggage, if only pedals are turned inside and the handle is turned parallel to the frame. Also the tyres must be deflated before acceptance.
- **Diving equipment:** Scuba tanks must be empty; batteries in torches must be removed. Backpacks should always be labeled with Limited Release Labels. No items may be attached to the baggage. bottles for compressed and emptied of air can only be accepted for carriage as checked baggage if completely deflated, the passenger should be requested to demonstrate this.
- **Buggies:** For passenger convenience, buggies will be labeled as LIMITED RELEASE at check-in, after which passengers may hand them over at boarding. They must be stowed in hold 3 and returned to passengers immediately upon arrival.

- **Wheelchairs or other Battery Operated Mobility Aids:** Wheelchairs will be carried free of charge if the passenger is dependent on it.
- Apply the “delivery at aircraft” procedure when personal collapsible wheel chairs/mobility aid devices are taken to the gate. Verify with and advise the passenger accordingly. Ensure the wheel chair/mobility aid has a name label, DAA tag and destination tag on it.
- Apply the following in case of battery operated wheelchairs and mobility aids:
  - If a wheelchair or mobility aid has an installed battery, inform the pilot in command about the location.
  - If the battery is removed from the wheelchair or mobility aid, inform the pilot in command about the location of the battery.
  - Issue a NOTOC and advise the pilot in command of the location of the wheel chair or mobility aid device if Wheelchair equipped with Wet-cell battery.
  - Stow and secure the wheelchair/mobility aid device to prevent unintentional operation and ensure it is protected from being damaged by the movement of baggage or cargo.
  - Loading is in a manner that prevents movement and damage from other cargo
  - Batteries are removed, protected and transported as per specifications applicable to the type of batteries;
  - Battery terminals are protected and electrical circuits are isolated.
- There are three main types of batteries used with wheel chairs or mobility aid devices:

Type of battery	Description
Non-spillable battery	Dry Battery (including integrated battery) Gel Type Battery Wet (sealed, non-spillable) battery
Spillable battery	*Wet battery
Lithium battery	Lithium ion battery



*\*All such batteries must be hold-checked. (except lithium-ion batteries) , lithium-ion batteries must be load to cabin under certain conditions, please observe IATA DGR Table 2.3A regulations when accepting lithium-ion battery powered wheelchairs.*

- **Accepting Wheelchairs/Mobility Aids with Non-Spillable Batteries**  
Pre-notification may be required and acceptance is subject to operator approval.
  - Battery terminals must be insulated to prevent accidental short circuits, e.g. by being enclosed within a battery container.
  - Battery must be securely attached to the wheel chair.
- **Accepting Wheel Chairs/Mobility Aids with Spillable Batteries**  
Pre-notification is required and acceptance is subject to operator approval.
  - Packing rules:
    - i. Wheel chair must be loaded, stowed, secured and unloaded while maintaining an upright position.
    - ii. Battery terminals must be insulated to prevent accidental short circuits, e.g. by being enclosed within a battery container.
    - iii. Battery must be securely attached to the wheel chair.
  - Battery must be carried in strong, rigid packaging as follows:
    - i. The outside packaging must be leak-tight, impervious to battery fluid and protected against spilling by securing to pallets or by securing them in cargo compartments using appropriate means of such as restraining straps, brackets or holders.
    - ii. The battery terminals must be protected against short circuits.
- Crew baggage may be presented at check-in or airside and should be clearly identified with a crew label as well as all flight details.

- **Medical baggage** can transport up to 10kgs as free of charge, if the passenger can declare a valid doctor report before 24 hours prior departure.
- **Ammunition** only small caliber ammunition for hunting and sporting guns in small quantities (max.5g gross) may be carried in checked baggage only (NOT in hand baggage). For details refer to the subsequent articles. Please see chapter 8 of this manual for details.
- **Golf equipment** is an extra service and not included in free baggage allowance. All golf bags should be weighted and actual weight should input to system.
- **Portable oxygen concentrators (POC), respiratory/ventilator devices, devices for sleep apnea (CPAP)** can be carried on board with the passengers inside the cabin and at the cargo compartment. Unless the ground personnel informs any restriction in relation to these equipment, there is no need to switch off the medical devices by the passenger for health purposes during their use throughout the flight and/or during takeoff/landing.  
These passengers are those who are carrying Portable oxygen concentrators (POC), respiratory/ventilator devices are permitted if they possess a written health report as English language issued by their own doctor or by the official doctor at the airport.  
Possessing a written health report for devices for sleep apnea (CPAP) is not necessary.
- **Personal oxygen cylinder** is not allowed to carry on board and at the cargo compartment due to safety reasons.
- **Prams/Buggies** Acceptable for carriage, if folded and tied to prevent unfolding. They should be loaded on the side of the door the cargo hold for quick retrieval during offloading.
- **Radio receivers** are acceptable for carriage, but must not be operated during flight.
- **Sporting Equipments** is an extra service and not included in free baggage allowance.
  - Generally, sporting equipment will be presented as separate pieces of checked baggage.
  - Accept sporting equipment as per Corendon Airlines procedure.
    - Apply procedures for fees and charges, and special handling.
    - Use limited release tag.
- **Musical Instruments** are transported in the cargo hold; our standard hold luggage rate applies to musical instruments. Passengers may also carry a small musical instrument with them as hand luggage. Only those musical instruments, including the case, which are no larger than 25 x 117 x 38 cm and no heavier than 8 kg can be transported in the cabin. Examples of musical instruments that meet these requirements are a viola, violin, flute, clarinet, bugle or trumpet.
- **Handling of Pets**
  - **General**
  - Prior to transportation a SITA message authorization by Corendon Airlines SITA Addresses (AYTOP7H) has to be sent to all stations. In exceptional cases and after co-ordination between the station concerned and the pilot in command, such animals may be accepted for carriage in the lower compartments without prior permission by AYTOP7H.
  - It is the responsibility of the passenger owning the animal, that the required passport which provides information about anti-rabies vaccinations and other information about the health of the animal in question can be submitted to the appropriate authorities at country of departure, transit and destination.
  - If the pets are transported within EU, they have to be at least **4 months old**.  
(*Rabies vaccination after 12 weeks + 21 days for training in vaccination protection*).

- If the pets are transported to/from non-listed third countries to EU countries, they have to be **7 months old** at the earliest.  
(*Rabies vaccination after 12 weeks + blood collection 30 days after vaccination + 3 months waiting period*).
- The “non-listed third countries” includes Turkey, Egypt, Morocco, Gambia etc.
- The whole list of “non-listed third countries” may be reached via following link:  
[https://www.bmel.de/DE/Tier/HausUndZootiere/Heimtiere/\\_Texte/HeimtiereEinreiseregung.html](https://www.bmel.de/DE/Tier/HausUndZootiere/Heimtiere/_Texte/HeimtiereEinreiseregung.html)
- The local regulations of the arrival destination for the particular pet should be considered, e.g. any pet (cat or dog) born outside the EU is allowed to enter an EU Country (other than England, Ireland, Malta and Sweden) for the first time after completion of certain procedures, which requires a duration of least seven months. Entrance to England, Ireland, Malta and Sweden requires an additional period of 6-months quarantine.
- There are two methods of pet carriage:
  - pets carried in the passenger cabin in an approved container. (PETC)
  - pets carried in the cargo compartment. (AVIH)
- **Pets in Cabin (PETC)**
- A maximum of 4 pets may be transported in the passenger cabin of an aircraft, provided that the weight of the pet including cage does not exceed 8 Kg and the container is not larger than 55 X 40 X 25 Cm and is waterproof on the base. Therefore a request has to be made one week before the flight by e-mail to Corendon Airlines Ground Operations as well as to Corendon Airlines SITA Address (AYTOP7H), and check if the allowance for pets have not been taken up.
- Two cats or two dogs of the same origin may be carried in one single container, and will be counted as 1 (one) pet. Only 1 (one) PETC per passenger is allowed. In cases of more than one pet accepted on to the flight, it shall be assured that the pets are seated far enough apart to prevent any kind of interaction. In cases where pet owners prefer to sit next to each other, the cabin chief may allow such seating as long as there is no growling, hissing, barking or any other kind of disquiet indication.
- Information regarding PETC must be state in the ‘SSR Report’ to inform the crew.
- Only 1 (one) PETC per row is allowed.
- Only window seat can be assigned (except first and emergency exits)
- Minimum PETC separation in cabin 4 rows.
- **Animals in Hold (AVIH)**
- Animals in Hold are transported as checked baggage in the aircraft hold. Maximum of 4 AVIH’s can be accepted to each flight.
- Animals such as dogs and cats only. For some specific flights falcons are also acceptable please see below references for falcon carriage)
  - *Passenger carrying falcon (only applicable for some special flights)*
  - *Corendon Airlines accepts the carriage of falcons in passenger cabin on some specific flights. Accompanied by the handler and all procedures of entry permits and documents required by countries of entry or transit and valid Health Certificates have been completed provided that acceptance of carriage will be at the passenger’s own risk. Advance arrangements are required during reservation process to enable the boarding station to obtain plastic sheeting and to block required seats.*
  - *Necessary conditions for carriage of Falcons are;*
    - I. Falcons shall always be hooded during the flight.*
    - II. A chain or light rope must be attached to the leg(s) of each bird one end is to be tied to the bird’s leg(s) and the other end to the aircraft seat*
    - III. Plastic sheets should be installed to cover the floor under the Falcons and any adjacent seats utilised.*
- Apply operator acceptance procedures with local customs requirements, animal age and health requirements.
- Only one animal per container, unless they are used to cohabiting.
- The flight crew and station should be informed of AVIH loading to ensure sufficient heat and airflow are maintained.



- The quantity of animals carried in cargo holds should be limited to 4 on the Corendon Airlines Aircraft. (Please see chapter 3 of this manual for detailed loading instructions.)
- **Container/ Cage Specifications: (ref - IATA Live Animals Regulations)**
  - i. Only rigid and water proof containers with a secure door are acceptable.
  - ii. Soft or cardboard boxes are not suitable for animals transported in the hold.
  - iii. Dimensions must be suitable with the allowable load dimensions in Chapter 6 of this manual.
  - iv. Door openings must be secured.
  - v. The cage must be solid, clean, of leak-proof bottom, absorbent material, have no wheels, and cannot be easily destroyed by the animal inside it.
  - vi. Animal(s) must be able to stand, move and lie.
  - vii. Bolts/screws must be complete/ assembled.
  - viii. Ventilation must be possible at all four sides.
  - ix. Water and feed dish must be attached.
  - x. "Keep upright" stickers must be attached on all four sides of the container whenever possible.
  - xi. The animal container is either labelled or imprinted on three sides with a "This Way Up" and on one side, with one "Live Animal" label.
  - xii. The container is handled as special baggage.
- **Service/Guide Animal**

In general, a service animal is an animal trained to perform duties to help an individual with a disability or medical problem in their day to day activities.
- **Trained guide dogs:** Seeing Eye or hearing dogs for BLND, DEAF, DEAF/ MUTE passengers pulling wheelchairs, carrying and picking up things for persons with mobility impairments, or, assisting persons with mobility impairments with balance. Passenger shown on manifest or PIL (Passenger Information List) with SVAN (Passenger with service animal in cabin) handling code.
- **Medical support dogs:** which alert the owner for epilepsy seizures, or similar issues. Passenger shown on manifest or PIL with SVAN (Passenger with service animal in cabin ) handling code.
- **Emotional support animals:** which assist their handler with a psychiatric disability, such as posttraumatic stress disorder, schizophrenia, depression, anxiety, and bipolar disorder. Only dogs and cats are accepted. Passenger shown on manifest or PIL with ESAN (Passenger with emotional support/psychiatric assistance or animal in cabin) handling code.
- **Search and rescue dogs:** only at emergency situations, and with special permission (normally considered as AVIH)
- Other animals such as companion dogs are not considered as service animals.
  1. The booking of the service animal has to be coordinated by the responsible Tour Operator or directly by the customer with Corendon Service Center department.
  2. Passengers are allowed to transport their service animal, either in the cabin - even if the animal weighs more than 8 kg - or in the hold (AVIH).
  3. Unless advised otherwise by Corendon Ground Operations, a maximum of 4 service animals can be accepted on a Corendon Airlines flight.
  4. Service animals will be counted as a PETC, and can be accepted in the limit of maximum number of PETC.
  5. The animals, which are categorized as dangerous at PETC/AVIH chapters, will not be accepted as service animal.

6. Guide dogs and medical dogs are permitted in the cabin without a muzzle, however the owner should bring a muzzle and use it in case dog starts to get restless during the flight.
  7. Emotional support dogs and search and rescue dogs must use a muzzle during flight. The muzzle will be checked during check-in.
  8. All service dogs must be on a leash at all times.
  9. A psychiatrist report will be required indicating the psychological need for emotional support animal. A medical report of the passenger will be required for accepting medical support dogs. The copy of the reports will be handed over to the cabin crew.
  10. The passengers with service animals are preferred to be seated window side of the cabin, provided that it is not an Emergency Exit row. The seating positions of the service dogs and the PETC's should be arranged with reasonable distance, in case there is a possibility of disturbance.
  11. The carriage of the service animal is free-of-charge.
  12. The passenger(s) must be stated on the PIL.
- The passenger is required to securely hold the dog's harness / leash for take-off, landing and during turbulence.
  - Trained Service Animals are not permitted on the seats or in emergency exit rows nor will the Trained Service Animal be provided food, water or inflight amenities made for guests (e.g. pillow, blanket, food, water, etc).
  - On a destination of 8 or more hours long, Corendon Airlines requires a passenger using a Trained Service Animal to provide documentation that the animal will not need to relieve itself on the flight or that the animal can relieve itself in a way that does not create a health or sanitation issue on the flight.
  - Corendon Airlines will not be liable for injury or to loss, delays, sickness or death of such animals or in the event that it is refused entry into or passage through any country, state or territory.
  - The following items are occasionally carried by passengers in their baggage. This list does not claim to be complete and will be updated as more cases found. Unless specifically mentioned otherwise, these items must be accounted against the passenger's free baggage allowance. For costed items, please check [corendonairlines.com](http://corendonairlines.com)
  - **DRONES**
    - Drones are considered Personal Electronic Devices - PED - (such as phones, laptops, cameras, etc.), due to the fact that they are powered by lithium-ion batteries.
    - These devices present a potential flight threat because of the amount of heat and energy.
    - ALL LIPO batteries must be carried on. Drone batteries must have their contacts wrapped and then put in a plastic bag and then be placed in a safety bag.
    - Drone batteries must be packed in carry-on baggage and they must be under 100 watt-hours.
    - (Wh) = Capacity (Ah) x Nominal Discharge Current (V)
  - **Powerbank**
    - Batteries, spare/loose, including lithium batteries, non-spillable batteries, nickel-metal hydride batteries and dry batteries for portable electronic devices must be carried in **carry-on baggage only**.
    - Articles which have the primary purpose as a power source, e.g. **power banks** are considered as spare batteries. These batteries must be individually protected to prevent short circuits.
    - **Lithium metal batteries:** the lithium metal content must not exceed 2 g.
    - **Lithium ion batteries:** the Watt-hour rating must not exceed 100 Wh.
    - Each person is limited to a maximum of 20 spare batteries.

- **Non-spillable batteries:** must be 12 V or less and 100 Wh or less. Each person is limited to a maximum of 2 spare batteries.

## 2.7 BAGGAGE SECURITY

### ➤ General

- Refer to the IATA Security Manual.

### ➤ Handling of Hold Baggage

- If passengers and crew members are required to personally identify their hold baggage before loading, do not load any baggage not identified.
- Ensure there is no opportunity for the exchange of cabin baggage for hold baggage which may contain items to be used in a planned act of unlawful interference.
- When screening of hold baggage gives rise to suspicion regarding the contents, the local screening authority will proceed as per local regulations.

### ➤ Carriage of Weapons in Hold Baggage

- Apply operator handling and acceptance procedures.
- Weapons are to be kept secured at all times either by approved personnel or locked away in a secure location.

### ➤ Security Removed Items

- Items not permitted in hand baggage that are removed by security screening personnel may only be accepted in checked baggage, as per operator handling and acceptance procedures.

### ➤ Arms

- Arms and any items, which may be used as a weapon, are not permitted to be taken into the passenger cabin.
- Police officers or Air Guards on official escort duty shall deliver their unloaded weapons to be stored in the cockpit. The police officers shall carry their ammunition in the passenger cabin. The weapons shall be returned after arrival at the aircraft before the passengers disembark. In all these cases the boarding station in advance shall inform the pilot in command.
- Passengers may carry hunting or sporting arms exclusively in checked baggage which must be loaded in the aircraft cargo compartment and which must be unloaded and contained in a break proof box.(e.g. marked gun case) Ensure that the safety catch is in active position and the weapon is not loaded.
- Any other items which can be considered being or may be used as weapons (such as antiques, souvenirs, large knives, scissors, axes, hatches, (e.g. for maintenance) must be without exception be carried in the aircraft cargo compartment or as a regular baggage.
- Explosives must never be carried as / in baggage in the aircraft cargo compartment or as/ in hand baggage in the aircraft passenger cabin.
- Passengers have to observe the regulations for import and transit of weapons and arms, applicable in the country of their destination and of any country they may transit, and shall be advised accordingly.

### ➤ Ammunition

- Ammunition for firearms must never be permitted to be taken into the passenger cabin.
- One passenger may carry a maximum of 5-kg (11-lb) ammunition for hunting or sporting arms only as/in checked baggage which is loaded in the aircraft cargo compartment.
- Ammunition must be securely loaded in boxes e.g. in traded boxes or cartons according to "IATA Dangerous Goods Regulations" larger amounts of ammunition more than 5-kg (11-lb) per passenger must be transported as air cargo only.
- Passengers with firearms have to check in at least 90 minutes prior to the scheduled time of departure.

- Corendon Airlines Ground Operations must be informed in such cases of Ammunition prior to acceptance.
- **Electronic Devices**
- Electronic devices that must be kept switched off during the whole flight are as follows:
  - Mobile phones
  - Radiophones
  - CD. Players
  - Remote controlled toys
  - Laptop printers
  - CD ROM Drive(Laptops)
  - Radios
  - Mini TV sets
- Electronic devices than can be used during cruise only are as follows: (After Takeoff Before Landing only)
  - Laptop Computers (only without CD ROM drivers)
  - Walkman
  - Game boys
  - Video cameras



*For further information please refer to Turkish DGCA circular, dated on 21.01.2014 with the reference number of 65355440-403.03.04/77*

### ➤ **Dangerous Goods in Baggage**

- Passengers and crew are permitted to carry certain items of dangerous goods in their baggage.
- Refer to the IATA Dangerous Goods Regulations (DGR) for a list of dangerous goods permitted in passenger baggage, their acceptance and handling procedures.
- Agents should be aware of commonly carried items and question passengers where there is a suspicion of their carriage. (e.g. camping equipment, hunters).
- In case dangerous goods which is discribed other than IATA Table 2.3A and is not permitted in passenger baggage is identified, it must be reported to the Operator, deemly necessary to the national aviation authority as instructed in GOM Chapter 8.1.11. These dangerous goods must be removed from the passenger's baggage and disposed of in accordance with local requirements.
- Dangerous goods items must be removed from cabin baggage when cabin baggage is transported as hold baggage.

### ➤ **Protection of Hold Baggages**

Corendon Airlines ensure procedures are in place to prevent items of hold baggage from being transported on such flights unless such items have been Individually identified as either accompanied or unaccompanied baggage and subjected to appropriate security controls based on risk assessment.

Hold baggage to be carried on an aircraft, shall be protected from unauthorized interference from the point at which it is accepted or screened into the care of the carrier until departure of the aircraft on which it is to be carried. The following measures shall be taken in protecting hold baggage:

- Prior to being loaded, hold baggage shall be held in the baggage make-up area or other storage area of an airport to which only authorized persons may have access.
- Any person entering a baggage make-up or storage area without authorization shall be challenged and escorted out of the area.
- Originating and transfer hold baggage shall not be left unattended on the ramp or plane side prior to being loaded on aircraft.
- Tail-to-tail transfer hold baggage shall not be left unattended on the ramp or plane side prior to being loaded.
- Access to lost-and-found offices in the terminal shall be restricted to prevent unlawful access to baggage and materials.

Access to the baggage make-up and storage areas shall be limited to those staff that has an operational requirement to enter the area. These shall include those involved in the loading, unloading and protection of hold baggage and persons authorized by the appropriate authority to be allowed access to the baggage make-up and storage areas.

At airports where not all staff are screened prior to access to security restricted areas, the appropriate authority shall ensure that between the baggage make up and storage areas and the aircraft, until the aircraft holds have been closed and secured immediately prior to departure, hold baggage shall not be left unattended. It shall be kept under surveillance at all times. Surveillance shall be sufficient to ensure that access to the hold baggage is limited to those persons associated with the handling of the relevant aircraft or loading of the baggage, and those persons otherwise authorized by the appropriate authority. Passengers may be allowed access to their own items of screened hold baggage where this is necessary provided that they are supervised throughout to ensure that no prohibited item is

- introduced into the hold baggage, or
- removed from the hold baggage and introduced into the aircraft cabin or security restricted area

### ➤ Hold Baggage Manifest

Corendon Airlines shall ensure that a hold baggage manifest is prepared for each of its aircraft engaged on an international flight and that the following information is recorded on each manifest by an authorized staff:

- a. The baggage tag number or details sufficient to identify separately each item of hold baggage placed on board the aircraft; and
- b. A mark, sign, or other indication showing whether each item recorded on the manifest is accompanied hold baggage or unaccompanied hold baggage; and
- c. A further mark, sign or other indication that it has been subjected to the appropriate security controls

### ➤ Mishandled Baggage

Corendon Airlines may conduct a security audit that secure storage areas have been established where mishandled baggage may be held until forwarded, claimed or disposed of in accordance with local laws. Mishandled baggage is usually the result of the baggage having;

- Been incorrectly tagged,
- Arrived without a tag,
- Missed a connecting flight,
- Been carried on the wrong flight.

Such baggage is held in a locked and secure storage cage or room. Access and key control is properly supervised and the baggage subjected to additional screening before being loaded into an aircraft.

Mishandled baggage shall be searched by ground staff in minimum 2 different angles according to local laws and hold in protected area for a period time as prescribed by the local Authority then immediately sent to its owner.

## 2.8 BAGGAGE IRREGULARITIES

- **The present instructions are to assist in the correct handling of passengers and baggage in case of baggage irregularities. They establish some general rules which, in principle Corendon Airlines handling agents are expected to comply with.**
- However, by no means should they limit personal initiative or exclude additional measures if these are considered necessary in the interest of both the passengers and Corendon Airlines provided

that the rules set forth hereafter are not violated and previous authorization has been requested from the Ground Operations Department whose address is available on the first chapter of this manual.

- Please see Lost Found procedures for detailed information related with baggage irregularities.

### **2.8.1. General Baggage Irregularity Instructions and Limits of Liability**

- The examination of any claim due to loss of or damage to baggage carried on board aircraft as well as the acknowledgement of liability in accordance with the provisions specified hereafter remains with Corendon Airlines or its insurers.
- In general, Corendon Airlines liability is governed by:
  - i. The Montreal Convention (formally, the Convention for the Unification of Certain Rules for International Carriage by Air) signed at Montreal on May 28th 1999.
  - ii. General Company Conditions of Carriage whichever may be applicable.
  - iii. EC 889/2002 dated 28.06.2004.

### **2.8.2. Property Irregularity Report (PIR)**

- Whenever a passenger wishes to notify loss or damage to part or his luggage, a PIR will be issued in triplicates. The person affected is strongly recommended to make himself the baggage check(s) for his damaged or lost property, which is of particular importance in case of missing baggage.
- Notifications of damage to or loss of baggage must be carried out immediately upon arrival at the airport of destination. Claims presented later should be in writing within seven (7) days from the date of receipt of baggage (in the case of damage) and in case of delayed delivery the complaint must be made at latest within twenty-one (21) days from the date the baggage was delivered.
- If the passenger receives his baggage without complaint, this is evidence that same has been delivered in good conditions.
- A PIR must be filled in the presence of the passenger concerned using a type writer or capital letters. All columns are to be completed. If known, specific details should be provided such as approximate age/value of a damaged piece if it is repairable/irreparable, etc. special remarks may be of help for the eventual settlement of the passenger's claim.

### **2.8.3. Distribution of PIR**

- PIR is distributed to:
  - i. First copy for file at Station, if necessary
  - ii. Second copy for the passenger (mandatory)
- The passenger who receives the report for AHL / DPR, etc. and would like to get in touch with the airline, should be directed to official web page of Corendon Airlines; <https://www.corendonairlines.com/lostandfound>

### **2.8.4. Damaged baggage**

- Any checked baggage already damaged when it is presented for check-in must be labelled with a Limited Release label and marked 'received damaged'.
- If baggage is returned to a passenger and found to be damaged, a Property Irregularity Report (PIR) must be made for the passenger and entered into the World Tracer System. Always refer passengers who wish to submit a claim to their own travel or baggage insurance company. Any passenger without such insurance may be advised to register their claim at: <https://www.corendonairlines.com/lostandfound>
- **Note: never settle a claim locally.**
- If the passenger cannot provide a baggage tag which belongs to the damaged baggage, DPR should be opened as a courtesy report. Passenger shall be informed by the handling agent about courtesy DPR.

**2.8.5. Missing baggage**

- When it becomes apparent that one or more pieces of a passenger's checked baggage are missing on arrival of a flight, a Property Irregularity Report (PIR) must be made and entered into the World Tracer System. If WTR cannot be used, Manuel AHL report has to be prepared by handling agent and the passenger should be directed to the following link <https://www.corendonairlines.com/lostandfound> Passengers must receive a local contact number of the station where the AHL report is issued.

**2.8.6. Rush baggage**

- "Rush baggage" is passenger's baggage which is not accompanied by a passenger(s) on their booked flight(s) for one reason or another and is directed to an alternative flight in order to be restored to that/those passengers."
- Rush Baggage shall not be transported unless it has undergone additional x-ray and has been found clean and labeled as Rush Baggage.
- The pilot in command must be informed about Rush Baggage.
- Rush baggage shall have Security search, hold in the protected area and sent to its owner immediately. Rush baggage is passed through the necessary security search, is kept in a beforehand-defined and protected place, and is sent to its receiver as soon as possible. Scanning of rush baggage is performed by using the EDS system, or using a level 1 EDS device allowing the operator to inspect all scanned images, or using conventional X-Ray device allowing the same operator to inspect on same device the images from 2 different angles, or by hand with support of bomb sniffing sensors on an open rush baggage. A declaration or a manifest is issued as a proof showing the method of scanning rush baggage. Corendon Airlines requests a written record showing that the rush baggage has been scanned at suitable standards

**2.8.7. Found Items on Board**

Any lost or forgotten object found on board aircraft must be handed over to the handling agent who will advise Corendon Airlines Lost and Found SITA Addresses (AYTLLXC). The Found item shall be transported with a Found Property Form, accompanied by an L&F form at all times. Found Property form shall be completed at all times, in order to control that the L&F item is being reconciled with its rightful owner in the same condition and content as it was initially found by Corendon Airlines staff.

**2.9 BAGGAGE ROOM/SORTING AREA PREPARATION****2.9.1 General**

The baggage room must prepare a sufficient and pre-determined number of baggage carts and containers in accordance with the expected passenger load for a flight

**2.9.2 Baggage Tags/Sorting**

Apply sorting and loading procedures into the cards based on Corendon Airlines' policy with respect to checked items according to the defined tags within this Part.

**2.9.3 Baggage Cut-Off and Verification Process**

Once a flight has been closed for check-in, the Baggage Sorting Area lead or the Baggage supervisor will:

- Review total checked pieces by matching the DCS system or verbally check in counter
- Pass on all baggage figures including baggage counts for each card number so that the total load summary can be prepared
- Conduct a baggage sorting area check to ensure there are no left behind bags

**2.9.4 Baggage Reconciliation**

Person and baggage reconciliation is a procedure that uses a verifiable tracking system to bring attention to hold baggage that has been loaded or is about to be loaded on a specific flight despite the passenger's

failure to board the aircraft concerned. The benefit of this procedure is to positively identify hold baggage that is not properly matched with a passenger or crew member on the specific flight, and to positively identify any passenger who has not boarded the aircraft as well as his or her associated hold baggage.

- i. Checked Baggage reconciliation shall be maintained between check-in, sorting area and airside after the completion of entire loading process just before each departure including:
  - standby passengers' checked baggage
  - gate delivery items
  - special types of baggage
  - off-airport and group check-in passengers
  - voluntary or involuntary deplaning
  - VIP baggage
  - Transit baggage
- ii. Baggage that is separated from the passenger may be subject to additional security controls in accordance with local regulations
- iii. Offload the hold baggage of any passenger who disembarks earlier than the station of arrival

If any mismatch;

- PIC shall be informed and necessary action shall be taken
- Each process owner shall be in alert and review the figure
- Each location through the baggage's enroute shall be checked.
- Each process (including transit baggage handling, gate delivery items etc...) shall be reviewed and checked.
- Baggage tags/destination shall be re-checked if it's needed
- All concerning shall be informed
- In case of need, baggage identifications may be performed with the PIC's confirmation
- Arrival station shall be noticed if necessary

### 3. AIRCRAFT & RAMP HANDLING

#### ➤ Aircraft Handling Procedures

- This chapter provides procedures for aircraft handling, including safety procedures.

#### 3.1. RAMP SAFETY IN AIRCRAFT HANDLING

##### ➤ Introduction

- Ramp safety rules and procedures promote safe ground handling. Therefore, the minimum safety rules and procedures defined in this section shall always be applied and understood by all personnel working on the ramp. Aircraft damage can endanger passengers, employees and aircraft. Disruptions may also negatively impact safe airline operations. Even a slight scratch or dent on an aircraft may result in a serious accident. If you see or cause any aircraft damage, you **MUST** report it.
- In order to ensure the safety on the ramp of passengers, staff, crew, aircrafts and load, the following precautions shall be taken:
  - i. No unauthorized persons shall enter the ramp;
  - ii. Smoking and the use of open fire is strictly prohibited;
  - iii. Ramp surfaces shall be frequently checked to prevent accidents caused by slipping/skidding on oil, ice or snow;
  - iv. Ramp personnel and crew shall wear ear protection as applicable;
  - v. All personnel, while on the ramp, shall wear high visibility clothing;
  - vi. Ground staff needs to be constantly alert in order to notice and remove loose objects and / or debris.

- vii. Ground staff shall ensure that the security zones around the engines of the aircraft are observed and that no personnel or equipment are within such zones when the signals for engine start-up are given.

### 3.1.1. General Ramp Safety

#### ➤ Danger Areas

- There is a particular risk of blast damage or injury from an aircraft engine's exhaust or intake. The risk is further increased if for any reason an aircraft stops and then applies the additional thrust required to "break away" and continue the maneuver.
- Vehicles and personnel must remain clear of aircraft danger areas when aircraft engines are running and/or the anti-collision lights are on.
- In order to prevent incidents and accidents caused by aircraft engines, you must never position yourself or equipment in the following critical areas before or during aircraft departure and arrival:
  - i. Engine Intake Area
  - ii. Engine Blast Area
  - iii. Propeller Rotation Area (where applicable)



**Danger:** Ground personnel and/or loose equipment must stay clear of the intake and blast areas.

#### ➤ Engine Intake Area

- Make sure the engine intake area is clear:
  - i. At arrival, until the engines have been switched off and are spooling down;
  - ii. At departure or just before pushback;
  - iii. At all times while engines are running.
- It is forbidden to pass through the blast area while the engines are running.
- Marshalls assigned to supervise start up and / or pushback procedures for CAI shall at all times check and double-check that no person or equipment is exposed to the jet blast. The hazardous area of the Boeing 737/800 and 737/8 MAX is as indicated below.

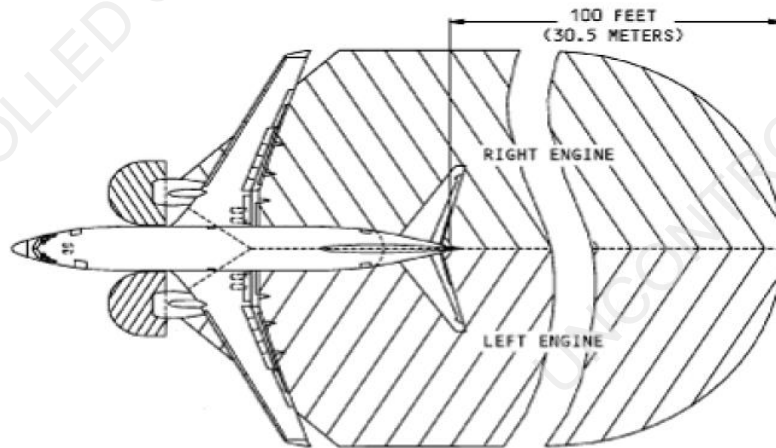

**EXHAUST HAZARD AREA**

**WARNING:** KEEP ALL PERSONS OUT OF THE DANGEROUS AREA DURING ENGINE OPERATION. IF THE SURFACE WIND IS MORE THAN 25 KNOTS, INCREASE THE DANGEROUS AREA AT THE ENGINE INLET BY 20 PERCENT.

CLEAN THE RAMP IF THERE IS SNOW, ICE, WATER, OIL OR OTHER CONTAMINATION, OR MOVE THE AIRPLANE TO A LOCATION THAT IS CLEAN. MAKE SURE THAT ALL PERSONS ARE SAFE BEFORE YOU START THE ENGINE. MAKE SURE THE PERSONS IN THE FLIGHT COMPARTMENT CAN SPEAK TO ALL PERSONS NEAR THE DANGEROUS AREA DURING ENGINE OPERATION. OBEY ALL OF THE GROUND SAFETY PRECAUTIONS FOR THE ENGINES. THE ENGINES CAN PULL PERSONS OR UNWANTED MATERIALS INTO THEM AND CAUSE INJURIES TO PERSONS OR DAMAGE TO EQUIPMENT.

➤ **Equipment Restraint Area & Equipment Restraint Line**

- The Equipment Restraint Area (ERA) is defined as the area of the apron bordered by a red line known as the Equipment Restraint Line—or otherwise indicated—in which an aircraft is parked during ground operations. The ERA must be free of obstructions and Foreign Object Debris (FOD) before and during aircraft arrival and departure.

**Aircraft Clearance Zone**



**3.1.2. FOD–Foreign Object Debris**

- Foreign Object Debris (FOD) is a general term which applies to all loose objects which are a danger to the safety and integrity of an aircraft and which, therefore, must not be left in any area where they would constitute a hazard.
- Every individual has a responsibility to ensure that the risk of damage to aircraft from FOD is minimized. All waste material must be properly disposed of such that it does not FOD and all FOD must be removed and properly disposed of as soon as it is discovered.
- Often the presence of FOD is due to the carelessness of personnel working airside and their lack of understanding of its consequences, or the movement of FOD into airside locations during high winds.

**➤ Examples of FOD**

- Plastic and paper, bags/sheets, rags
- Metal: nuts and bolts, empty oil and hydraulic fluid cans, tools and equipment
- Natural objects: rocks, pebbles and wood
- Other debris: burst ballast bags, luggage handles and luggage wheels, etc.

**➤ Results of FOD**

- Foreign object debris may be ingested into aircraft engines causing damage leading to engine failure. This is especially critical if it occurs in flight, particularly during the take-off phase.
- In addition, FOD can damage tires, the undercarriage, control systems and other parts of the airframe. All such damage could lead to inflight failures.

**➤ FOD Checks:**

- The following checks must be conducted prior to any aircraft movement or after servicing operation:
  - i. Check ground equipment staging and parking areas in proximity to area of operation.
  - ii. Ensure routine checks are made of ground equipment (including floors of enclosed cabins).
  - iii. In ramp areas ensure that anything carried in or on a vehicle is secured.
  - iv. Before aircraft arrival, conduct a FOD walk of the aircraft parking stand removing all FOD found.
  - v. Pick-up and dispose all FOD in designated garbage bins, where provided.

**3.1.3. General Safety Instructions for Ground Support Equipment (GSE)**

- Apply these procedures whenever operating GSE on the ramp.
- Only drive or operate GSE if you are trained and authorized for that specific equipment type.
- Corendon Airlines shall ensure the followings by auditing, inspections, postal audits, etc. of the GSE suppliers:

- A preventive maintenance program plan for each type of equipment
- Maintenance completed on such equipment is recorded;
- Such equipment remains serviceable and in good mechanical condition



*Before operating any equipment, check the aircraft for possible damage in the equipment contact zone and immediately report any damage found.*

*Do not continue to approach the aircraft with any GSE in the area where damage has been found.*

*Use all safety devices fitted on GSE (e.g. bumpers, handrails, stabilizers, etc.) during aircraft handling and servicing.*

*Ensure protective rubber bumpers ARE NOT compressed against aircraft fuselage.*

**3.1.3.1 Basic Operating Requirements for GSE**

- a) Securely stow GSE cables and hoses, where fitted, prior to transportation and when not in use.
- b) GSE shall not impede the accomplishment of other aircraft handling operations in progress unless there is an important reason to do so.

- c) Check that all areas of GSE are free of contamination, FOD and safe for use prior to and throughout the operation.
  - d) All safety rails shall be fully retracted/lowered prior to positioning and removal, where possible.
  - e) Seat belts shall be worn, where fitted, except where repositioning equipment is within the same operational area, e.g., within the parking stand or baggage makeup area.
  - f) Before moving any GSE/Vehicle ensure all its doors are closed, where fitted.
  - g) GSE shall not be operated while using handheld Portable Electronic Devices (PEDs), including cellphones, portable music players, portable game units or earpiece or headset.
  - h) GSE shall only be used for its intended purpose, including for specific aircraft types.
  - i) Prior to movement of any GSE/Vehicles, the intended travel path shall be checked and confirmed clear of personnel, equipment or other obstacles.
  - j) GSE with lifting devices shall not be driven or towed in the raised position, except for final positioning onto the aircraft.
  - k) The GSE platform shall not be operated while in motion.
  - l) Once motorized GSE is in its servicing position at or near the aircraft:
    - 1. Apply the parking brake with the gear selector in park or neutral (if no selection for park).
    - 2. Turn off the engine, unless required when in operating/servicing mode.
    - 3. Install GSE wheel chocks, where equipped.
    - 4. If equipped with stabilizers, ensure they are deployed before the GSE is used for servicing. Deploy other safety devices (e.g., active proximity sensors, safety rails), if fitted.
    - 5. When motorized GSE is in operating/servicing mode, remain in a position whereby the emergency controls can be promptly accessed. This includes the immediate vicinity of the controls or an immediately adjacent and accessible location;
    - 6. If motorized GSE is not fitted with external emergency controls, the operator shall remain in the operating position and in control of the equipment when in operating/servicing mode.
- Note:** As an exception for pushback tractor, the engines may need to be left running unattended:
- 1. *While conducting a single person pushback operation*
  - 2. *To avoid specific restart by maintenance function*
- If unattended, apply the parking brake and place the gear selector in park, or neutral if no selector for park.
- m) When GSE is chocked:
    - 1. Place one chock at the front and one chock at the rear of the same wheel.
    - 2. Chocks shall be centered on and in contact with the wheel.
  - n) When unattended motorized GSE/vehicle is positioned in or adjacent to the ERA, other than as described in sub item (l):
    - 1. Turn off the engine. In extreme cold weather conditions where local procedures permit engines running unattended, the motorized GSE shall be chocked.
    - 2. Apply the parking brake with the gear selector in park or neutral, (if no selection for park) and, when equipped, install wheel chocks.
  - o) The ground power unit (GPU) and preconditioned air (PCA) may be left running unattended when connected to the aircraft, provided the serviceability and fuel levels are checked periodically.
  - p) A No-Touch policy (i.e., GSE/PBB shall not touch the aircraft) shall be employed for all GSE/PBB types that are not equipped with self levelling sensors. The equipment shall be positioned in a way that ensures:
    - 1. The protective rubber bumpers do not touch the aircraft fuselage.
    - 2. The gap between GSE/PBB and aircraft shall not allow a person or large piece of equipment to fall through. As a guideline, a gap of 5 cm (2 in.) or two fingers should be maintained between the device and the aircraft.
    - 3. Check that throughout the turnaround process a clearance is maintained between the GSE and the fuselage to allow vertical movement.

- r) For GSE and PBB equipped with self-levelling sensors. Continue movement until the protective rubber bumpers just touch the aircraft (but shall not be compressed against the fuselage) or the proximity sensors stop the movement.
- s) Access to firefighting equipment or the fuel hydrant emergency stop switch shall not be obstructed.
- t) Check all GSE assigned to them prior to initial use, particularly the parking brakes, rubber protective bumpers, safety systems and in-life service date of onboard firefighting equipment's. If found to be defective, the GSE shall be reported, tagged as "Out of Service" and removed from operations, when applicable.
- u) GSE shall be parked in the designated airside equipment parking areas when not in use.
- v) Driven safely on the apron and within the ERA;
- w) As applicable to equipment type, operated with a load that is securely locked
- x) Use a guide person when vision is restricted. The guide person shall be able to accurately judge clearances and communicate signals to the driver/operator. Stop immediately if visual contact with the guide person is lost. Movement shall not continue until visual contact is re-established.
- y) As applicable to equipment type, operated with stabilizers, handrails, attachment fittings, transfer bridges and/or platforms correctly deployed when in position at the aircraft
- z) Positioned so as not to obstruct an aircraft evacuation or the free movement of other GSE
- aa) Apply parking brakes and place the gear selector in the "PARK" or "NEUTRAL" position on all GSE when it is parked or positioned.
- bb) When positioning GSE, make sure that clearance is kept between all GSE and the aircraft to allow vertical movement of the aircraft during the entire ground handling process—preventing contact between the aircraft and equipment.
- cc) Do not carry extra personnel during GSE movement without an approved seat—apply the "no seat—no ride" principle.
- dd) After positioning equipment on the aircraft, raise all safety rails on conveyor belts, loaders and other elevated devices—except where restricted by aircraft type.
- ee) Do not leave any vehicle unattended with its engine running.
- ff) If equipped with stabilizers, ensure they are deployed before operation.
- gg) Do not drive GSE with lifting devices in the raised position, except for final positioning of the GSE onto the aircraft.
- hh) Do not allow any GSE such as tractor, pallet transported, baggage/cargo carts and dollies to move or be positioned under the aircraft fuselage.
- ii) Do not move any GSE, including passenger boarding bridges, towards the aircraft unless all of the following criteria are met:
  - i. Aircraft has come to a complete stop;
  - ii. Engines have been switched off and are spooling down;
  - iii. Anti-collision lights are switched off;
  - iv. Wheel chocks are positioned;
  - v. Ground/Flight Crew communication has been established, and clearance has been given, if applicable.



*The above does not apply for ground power units (GPU).*

### 3.1.3.2 Non-Motorized GSE

- When parked, all non-motorized GSE must have brakes set or chocks in place when not connected to motorized vehicles.

### 3.1.3.3 Passenger Boarding Equipment

The operator of the passenger boarding bridge must be trained and authorized to operate the boarding bridge and shall the followings:

- When positioning equipment at doors and driver/operator vision is restricted, use a guide person.

- Make sure the guide person is in a position to accurately judge clearances and communicate signals to the driver/operator.
- Stop immediately if visual contact with the guide person is lost. A guide person is not required if the equipment is fitted with systems (e.g. sensors) that enable the operator to accurately judge clearances and properly position it to and from the aircraft.
- Make sure the equipment does not contact the wing root leading edge fairing that extends under certain cabin access doors and any other sensors or fairings.
- Make sure any sliding rails and canopies on the equipment are fully retracted during positioning, and fully extended only once the equipment is in position.
- If the equipment's sliding rails cannot be extended until the door has been opened, make sure they are extended immediately upon door opening.
- If the boarding equipment is not equipped with an auto-level feature, position the floor of the boarding device 6 in/15 cm below the door sill. This reduces the possibility that the aircraft door will rest on the boarding device in the event that the aircraft settles during loading and unloading.
- Report any malfunction of the bridge to the appropriate person/authority.
- Check that the bridge is serviceable before use.
- Parked in a fully retracted position prior to aircraft arrival and departure movement
- Moved slowly to the aircraft cabin access doors;
- The bridge must be fully retracted before aircraft arrival and departure.
- Secured to prevent movement from non-authorized persons
- The safety barrier must be in place whenever the bridge is not at the aircraft.
- Make sure the movement path is clear before moving the bridge.
- Only the bridge operator shall be in the bridge while it is moving.
- Move the bridge slowly towards the aircraft until the bridge touches the aircraft—avoiding any aircraft sensors.
- Keep sufficient clearance between the bridge and the underside of the cabin door or as directed by the cabin door markings.
- Engage any safety systems and auto-leveler features if applicable. If the bridge is not equipped with an auto-leveler, the bridge must be attended by an operator whenever it is positioned at an aircraft.
- Close the cabin door before removing the bridge.
- When positioning is complete, the bridge controls must be isolated as applicable.

#### **3.1.3.4 Passenger Stairs**

- Check that the passenger stairs are serviceable before use.
- Check that the walking surfaces are safe for use.
- Passenger stairs must be outside the ERA before aircraft arrival and departure.
- Make sure the movement path is clear before moving the passenger stairs.
- Move the passenger stairs slowly towards the aircraft, avoiding any aircraft sensors, until either the protective bumpers just touch the aircraft or the equipment's proximity sensors stop the movement.
- Keep sufficient clearance between the passenger stairs and the underside of the cabin door, or as directed by the cabin door markings.
- Engage any safety systems and auto-leveler features if applicable. If the passenger stairs are not equipped with an auto leveler, the level of the passenger stairs must be monitored and adjusted as required.
- Deploy stabilizers if fitted.
- Extend side rails after the cabin door has been opened.
- Make sure passenger stairs are positioned so that the cabin door can be used as an unobstructed escape route in the event of an emergency/evacuation.

- If the passenger stairs are towed, disconnect them from the tractor and manually position them on the aircraft.
- Close the cabin door before removing the passenger stairs.
- After the cabin door has been closed, confirm there is no staff on the stairs prior to retracting stabilizers. If the stairs are not positioned on the aircraft, they must be pulled back sufficiently to allow the deployment of slides in case of emergency.



*Cabin doors shall only be in open position if there is any GSE or boarding device positioned at the door. Cabin doors may never be opened without any equipment positioned at the aircraft.*

*There is a risk of falling while operating cabin doors.*

*Slide deployments can be fatal. If an armed door begins to open, do not attempt to hold the door, as you risk being seriously injured or killed by doing so.*

### 3.1.3.5 Aircraft Loading Equipment

- Belt Loader
- The following precautions must be taken when operating a belt loader:
- The boom of the belt loader must never be positioned inside the cargo hold of any aircraft.
- Position and remove a belt loader in a straight line with the cargo hold door at a 90 degree angle to the aircraft fuselage.
- Ensure the boom is clear of the aircraft or other obstacles before making a turn.
- The rubber bumpers on a conveyor belt loader must NEVER make contact with the aircraft. The minimum distance to be maintained at all times is 1 in/2.5 cm from the fuselage.
- Always raise side handrails as soon as belt loader is positioned. Make sure they do not touch the aircraft fuselage.
- Hand rails may be lowered to accommodate large items during loading and offloading.
- Do not stand or walk on the belt when a hand rail is lowered.
- Specially designed belt loaders (e.g. Ramp Snake or Powerstow) require the equipment to be positioned inside the cargo hold.
- Do not sit or stand on a conveyor belt while it is in operation (up or down).

### 3.1.4 Ground Support Equipment Safety Driving and Parking inside ERA

- Apply the following precautions when driving or parking Ground Support Equipment (GSE) within the ERA:
- Make a minimum of one complete stop with all motorized vehicles/equipment prior to entering the ERA.
- Conduct a “Brake Check” or “Safety Stop” by coming to a full and complete stop to confirm the serviceability of the brake system on the vehicle and to test the apron surface.
- This action MUST be carried out even if there is no Equipment Restraint Line marked on the apron.
- This stop must be conducted at a distance of no less than 5 m/15 ft. from the aircraft.
- Do not drive GSE faster than walking speed.
- Maneuver GSE carefully in order to prevent personnel injury and/or aircraft damage.
- When reversing vehicles or equipment with limited rear-view visibility inside the Equipment Restraint Area, make sure you are:
  - i. Guided by an agent using standard IATA signals, and/or
  - ii. Assisted by means of a rear-view video or mirror.
- Any moving vehicle that is not positioned at the aircraft, must stay outside operational safety buffer zone.
- Do not drive or park under the aircraft fuselage and/or wing.

#### ➤ Exceptions

- GSE and vehicles needed for aircraft servicing (e.g. aircraft refueling truck, water servicing truck, toilet servicing truck).

**3.1.5 Fire****3.1.5.1 Fire Prevention and Protection**

Personnel must always be vigilant for fire hazards and potential sources of fires in their areas of operation and try to mitigate or eliminate them during the operations (e.g., fueling and defueling operations, open wires, dangerous goods handling, GPU connections and use of electrical equipment). To eliminate conditions that may lead to fire:

- a) Personnel must never smoke airside except in a designated smoking area.
- b) All personnel shall be familiar with the location and use of firefighting equipment, fire alarms, fuel hydrant emergency shut-off valve, etc.
- c) All personnel must be familiar with assembly points.
- d) Emergency exits must be kept clear/unobstructed at all times.
- e) Exercise good housekeeping in the airside areas to eliminate the risk of fire.
- f) Dispose of garbage into the designated waste bin and do not allow garbage to accumulate.
- g) All fuel/oil leakages must be contained as soon as possible, and the area cordoned off. (e.g., using safety cones, caution tape).
- h) Smoke from GSEs/vehicles must be reported immediately.
- i) Do not refuel any GSE/equipment while the engine is running any GSE/equipment while the engine is running or while using electronic devices.
- j) GSEs/vehicles should only be parked as follows:
  1. Within the defined equipment parking areas;
  2. In a manner that does not obstruct access to firefighting equipment and the fuel hydrant emergency shut-off valve.

**3.1.5.2 Actions in the Event of a Fire**

- a) In the event of a fire, carry out the immediate actions specified in GOM 7.5
- b) In event of GSE/vehicle fire, additionally, carry out an assessment and only if considered safe to do so:
  1. Fight the fire using available fire extinguishers.
  2. Move affected GSEs/vehicles away from the aircraft and operational area to the extent practical.
  3. In case the affected GSEs/vehicles cannot be moved, move adjacent GSEs/vehicles away to avoid spreading the fire.

**3.2. POTABLE WATER SERVICING**

- Drinking water for CORENDON AIRLINES aircraft can only be uplifted at the stations where it is accepted by the health administration. Station water uplift is only permitted with pre authorization from Corendon Airlines Ground Operations for additional disinfectant a "Certisel combine liquid" Water Analyses report must be sent to Corendon Airlines Ground Operations in every three months period.
- Potable water systems are susceptible to contamination by bacteria and other micro-organisms. It is therefore essential that such water is free from chemical substances/micro-organisms which might cause illness, and that it is disinfected. Potable water services shall not be filled up from the same tap as toilet services. Potable water services and toilet services shall not be parked in the same area. Personnel engaged in toilet servicing shall not perform water service.
- The water used for uplift shall fully meet the hygiene and testing requirements detailed in AHM 440 and IGOM 3.6.3.

### 3.2.1. Filling the potable-water tank

- The Boeing 737/800 and 737/8MAX has a pressurized water system serving on-board requirements except toilet flushing. There is one potable-water service point under the aft fuselage.
  - i. Open the door to the potable water service panel;
  - ii. Open the cap on the water fill connection;
  - iii. Connect the water supply hose to the water fill connection;
  - iv. Turn the handle on the water tank fill valve to open;
  - v. Fill the potable water tank with water until water flows from the overflow port on the service panel. (Use water at a pressure of 25psi);
  - vi. Stop the supply of water to the potable water tank;
  - vii. Turn the handle for the water tank fill valve to closed;
  - viii. Disconnect the water supply hose from the water fill connection and let the fill line drain;
  - ix. Close the cap on the water fill connection;
  - x. Close the door on the service panel.

#### ➤ General Hygiene Precautions

- To perform water servicing you must:
- Wear clean clothing;
- Thoroughly wash your hands using soap or wear new disposable gloves, before starting water servicing:
  - i. Do not fill the potable water service unit from the same water source as the toilet service unit.
  - ii. Do not park the potable water service unit and the toilet service unit in the same area.
  - iii. Do not service the toilet and water on the aircraft at the same time. Certain aircraft types are exempted from this rule.
  - iv. Servicing personnel shall adhere to strict hygiene and safety standards while performing potable water servicing to prevent contamination of potable water supplies.
  - v. Servicing personnel shall work in a clean and safe manner, ensuring compliance with established procedures.
  - vi. Servicing personnel should wear single-use or disposable gloves during all potable water servicing activities. Gloves shall be changed between tasks to maintain hygiene and minimize the risk of contamination.
  - vii. The cleanliness of the water servicing vehicle shall be checked before and after servicing to ensure a sanitary working environment and compliance with hygiene standards.

### 3.2.2. Potable Water Units Servicing Procedure

#### ➤ Filling Aircraft Water Tanks

- Fill the aircraft water system as close to the departure time of the aircraft as possible.
- Before connecting the aircraft filling hose to the aircraft, flush the hose.



*When the filling hoses are not in use, the nozzles or connectors must be protected from contamination either by the use of appropriate covers or by immersing them in receptacles containing chlorinated water.*

### 3.2.3. Water Servicing During Freezing Conditions

- The following actions must be followed to prevent freezing of the water in the aircraft water tanks and lines during freezing conditions:

- i. Drain the aircraft water tanks if instructed by the Corendon Airlines as per the operating procedures. Disposal of water in accordance with airport operator requirements

Ensure the fill line is fully drained before closing the cap to prevent freezing of fluid inside.



*Keep aircraft cargo doors closed to prevent water lines from freezing when the cargo compartments are not being loaded or offloaded.*

*Do not attempt to remove the frozen substance in the fill lines or connections or on the service panels. Contact maintenance immediately.*

### 3.3. TOILET SERVICING

#### ➤ Introduction

- The complete procedure for servicing the aircraft toilet waste tank consists of the following 3 steps:
  - i. Draining of the waste tank(s);
  - ii. Flushing of the waste tank(s);
  - iii. Adding an amount of pre-charge and/or a concentrated deodorant pre-charge product—as applicable.



*Toilet fluids are corrosive. Prior to servicing, inspect the toilet servicing panel on the aircraft for signs of leakage. If any horizontal blue streaks are observed, the blue streak must be cleaned prior to servicing. After cleaning, look again for signs of leakage.*

*Blue ice build-up in higher altitudes may influence airworthiness. In case of a possible leak, immediately inform the airline representative, ground engineer, or advise the flight crew.*

#### ➤ General Hygiene Precautions

- Wear heavy rubber gloves, full face protection and protective clothing against harmful wastes when performing toilet servicing.
- Do not park the toilet service unit in the same area as the water service unit nor at the water filling point.



*Once an agent has performed toilet servicing on an aircraft, the same agent **CANNOT** perform water servicing during the same shift.*

#### 3.3.1. Toilet Servicing Procedure

- Each aircraft type has specific requirements for toilet servicing and the amount of precharge and/or concentrated deodorant precharge product. Refer to the Corendon Airlines OM for aircraft type specific instructions for more details.

##### General

- Prior to opening a toilet service panel, check for stains around the panel.
- While opening the service panel, stay clear and watch for signs of leakage.
- Stay clear of the drain fitting cap while opening, and watch for signs of leakage.
- If required for a recirculation toilet, stir up the waste tank contents with an appropriate stick.
- Make sure the drain hose Y-fitting coupling is connected correctly, before a drain valve handle is pulled.
- Empty the waste tank(s).
- Flush the waste tank(s) twice and empty them again.
- Precharge the tank(s) with the correct quantity of water and disinfectant—as applicable.
- Fill the waste tank(s) with the correct amount of water and concentrated deodorant precharge packets or pre-mixed fluid as applicable. For aircraft equipped with a conventional toilet system, fill the waste tank(s) with the correct amount of water and precharge, or concentrated deodorant precharge
- After servicing ensure that there are no leaks at the drain fitting cap and the end of the drain hose Y-fitting coupling.

- Close the nozzle tightly in order to prevent the accumulation of ice during flight and wipe off residual water and disinfectant.
- Check for possible leakage.
- After servicing close and latch the fitting caps and service panel door.



*Inform aircraft maintenance or flight crew, if:*

*Fluid leakage is observed.*

*The drain valve will not open or the waste tank cannot be drained.*

*Report any spillage of waste to the supervisor and Corendon Airlines.*

- **Draining**
- Drain the aircraft waste system into the waste tank of a Toilet Service Unit.
- Observe the waste drain hose during draining to confirm that the waste tank is completely emptied. The hose will also vibrate for a few seconds as the contents of the waste tank pass into the waste tank of a Toilet Service Unit.



*Drain the waste tanks one at a time for optimal results.*

### 3.3.2. Servicing During Freezing Conditions

- Take the following measures to prevent freezing of the fluid in the aircraft toilet tanks and lines during freezing conditions:
  - i. Drain the waste tanks if the aircraft is parked in the open for several hours without electrical power supply and the temperature is, or is expected to be, below the freezing point, as per the operating airline procedure.
  - ii. Fill the aircraft toilet system only after electrical power supply has been restored, and as close to flight departure time as possible.
  - iii. Ensure the fill line is fully drained before closing the cap to prevent freezing of fluid in the fill line.



*Do not attempt to remove the frozen substance in the fill lines or connections or on the service panels. Contact maintenance immediately.*

## 3.4. SAFETY DURING FUELLING/DEFUELLING

- Fuelling or de-fuelling of a CAI aircraft shall always be conducted or supervised by:
  - A licensed ground engineer and /or
  - A flight crewmember.
- The commander shall confirm that the fuel quantity ordered is sufficient to meet the calculated requirements for the flight. During the pre-flight inspection a flight crewmember shall confirm that the correct type, grade and quantity of fuel have been loaded.
- Only those fuel types that are specified for the aircraft in the OM Part A shall be used for fuelling.
- CAI shall ensure fuel delivered and loaded onto aircraft is free from contamination and of the correct grade and specifications for each aircraft type by auditing, inspection, testing, postal audits, on site audits, etc...



### 3.4.1. Fueling Safety Zone

- The Fueling Safety Zone (FSZ) is defined as an area of at least 3 meters in any direction from the centre-point of all fuel vent exits, refueling plugs, aircraft refueling ports, fuel hydrants, fuel hoses and fueling vehicles. This distance may be further increased as required by local airport or civil aviation regulations.
- The following precautions shall be taken when fueling or de-fueling CAI aircraft:

- i. At least one flight crewmember or a qualified ground engineer shall remain on the flight deck;
- ii. A two-way communication shall be established and shall remain available by the aircraft's inter-communication system or other suitable means between the ground crew supervising the fueling and the qualified personnel on board of the aircraft;
- iii. Fueling or de-fueling during lightning activity is not permitted;
- iv. A ground power unit shall not be connected or disconnected;
- v. Crew members, staff and passengers on board shall be informed of commencement and termination of fueling;
- vi. The fuel truck or other fuel installation shall be grounded to the aircraft structure before the hose is extended, and remains so until fueling is complete;
- vii. The fuel truck shall be parked in such a manner that at all times it can drive away forward without any delay;
- viii. Smoking is not permitted while fueling is in progress;
- ix. Fire extinguishing equipment suitable for at least initial intervention in the event of a fuel fire is readily available, and personnel have been trained in the use of such equipment;
- x. If a ground power unit, a jet starter or an air conditioning unit is located within the fueling zone or which has an exhaust discharging into the zone is stopped for any reason during a fueling operation, it should not be restarted until the flow of fuel has ceased and there is no risk of igniting fuel vapors.
- xi. Do not use ANY hand held portable electronic devices, including cell phones, portable music players, portable game units or an earpiece or headset
- xii. Do not leave vehicle engines running unnecessarily;
- xiii. Position all GSE and vehicles so they do not obstruct the fueling vehicles' escape route;
- xiv. Do not allow any passengers to enter the FSZ;
- xv. Avoid the use of motorized GSE within the FSZ;
- xvi. Do not park any equipment in the FSZ;
- xvii. Ensure fuel hoses are protected and all ground equipment is kept a minimum of 1 meter (3 ft.) away from any fuel hose on the stand that is connected between a fuel truck and an aircraft.

#### **3.4.2. Fuel Spillage / In the event of a fire**

- Take the following safety measures whenever a fuel spill occurs:
  - i. Fueling is stopped. Activate the emergency shut-off valve where installed.
  - ii. Notify the person in charge of fueling and the Pilot in Command or qualified persons on board and appropriate Authority and the Emergency Services.
  - iii. Summon the Airport Fire Service in the event of a fire or fuel spill or kerosene contamination.
  - iv. Verify with authorities/supervisor whether to stop all activity around the aircraft.
  - v. As far as possible, restrict all activities inside and outside the spill area to reduce the risk of ignition.
  - vi. Evacuate all persons from the immediate area.
  - vii. If safe to do so, mobilize firefighting equipment as standby protection until the arrival of the airport emergency services.
  - viii. Control the movement of unauthorized personnel and equipment into the area.
  - ix. All electrical equipment in use during the fueling operation must be switched off immediately.
  - x. Do not start APU until the spilled fuel is removed and there is no further risk of spilled fuel or vapours.
  - xi. Normal operations must not be resumed on the aircraft or any engines started before the person in charge of the emergency, determines that it is safe to continue.
  - xii. If fuel is spilled on any item, then such items are NOT TO BE LOADED into the aircraft.
  - xiii. In the event of a fire occurring either on or in the vicinity of the aircraft STOP the fueling operation and call the emergency services.

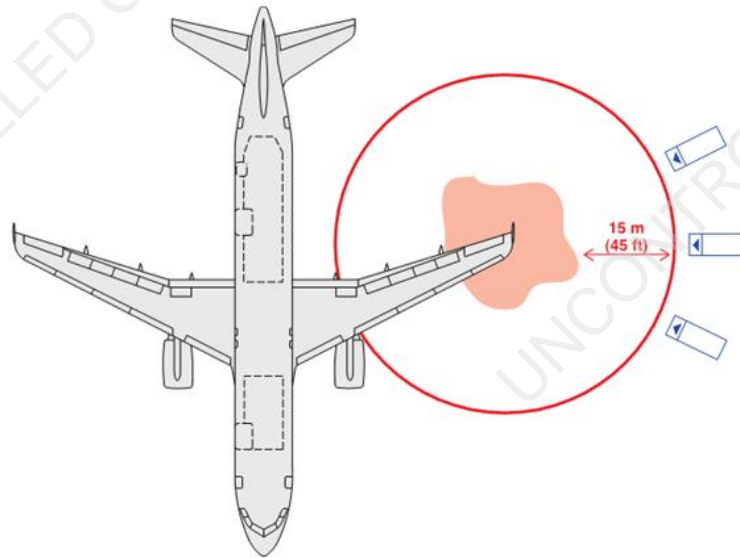

### 3.4.3. Refueling/Defueling with Passengers or crew embarking, on board or disembarking the aircraft:

Refueling with passengers on board may be permitted by the pilot in command unless the aerodrome imposes specific regulations or restrictions (presence of fire-brigade and/or adequate extinguishers etc.) and prerequisite it is adhered to the following safety regulations in addition to general safety precautions.

Defueling with passengers on board is strictly prohibited.

The complete process must be executed in coordination with the pilot in command and cabin crew must be informed about start and end of fueling, to ensure adherence to all necessary safety regulations.

The Handling Agent must ensure that fueling is supervised by a qualified person (e.g. Ramp Agent) on ground in the near vicinity of the aircraft who will remain capable to the following precautions:

- When refueling with passengers or crew embarking, onboard or disembarking the aircraft, relevant staff shall:
  - i. Keep designated exits clear. An exit may either be a bridge into a terminal building, a cabin door or a passenger stair truck positioned on an open cabin door.
  - ii. The ground area beneath aircraft exit doors that have been designated for rapid deplaning or emergency evacuation is kept clear of obstructions.
  - iii. Passenger stairs and bridges are clear of FOD. Where a boarding bridge is in use, an interior access path is maintained from the aircraft to the terminal. Where a passenger boarding bridge is not in use, aircraft passenger steps or an alternate means of emergency evacuation is in place.
  - iv. Communicates with the flight crew or other qualified persons on board the aircraft.
  - v. Provides notification to the flight crew or other qualified personnel on board the aircraft and/or other appropriate personnel engaged in aircraft ground handling activities when fueling is about to begin and has been completed.
  - vi. Provides notification to the flight crew or other qualified personnel on board the aircraft when a hazardous condition or situation has been determined to exist.
- During fueling operations, below safety procedures shall also be followed:
  - vii. Establishment of a bonding connection between the fueling vehicle and aircraft to provide for dissipation of electrical energy that may develop.
  - viii. A prohibition from connecting or disconnecting electrical equipment to the aircraft.
  - ix. Provisions for operation of the aircraft APU.
  - x. Prevention of damage to the fuel hose.

- xi. A requirement for the cessation of aircraft fueling when it is determined lightning is a threat.

#### 3.4.3.1 Additional Safety Measures during Fueling with Passengers on Board

- If fueling is intended to start while passengers are still embarking / disembarking or fueling with transit passengers on board, the airport fire brigade must be informed by the handling station management about the fueling process and the position of the aircraft.
- The presence of the fire brigade at the aircraft may not be required according to local regulations. If local regulations do not require the stand-by presence of a fire brigade, the pilot in command may ask for fueling with the passengers on board.
- If local regulations demand the presence of a fire brigade, it must be on stand-by within operating distance. If a fire brigade is not available, an approved fire extinguisher must be positioned at the aircraft together with instructed personnel.

#### 3.4.4 Personal Protective Equipment (PPE)

All personnel shall be issued with and wear appropriate PPE as required for their role and as per local regulations to include:

- Safety footwear
- Hearing protection
- High visibility clothing
- Gloves
- Any other specified PPE as per local requirements

**Note:** Neckties or other loose hanging accessories which may pose risk shall be of the quick release type (clip).

### 3.5. CATERING OPERATING PROCEDURES

#### Safety Procedures:

- Aircraft catering vehicles are designed to allow rapid transfer of catering trolleys and other supplies to and from aircraft as part of the preparation of aircraft for flight (turnaround). Aircraft catering vehicles must be designed in accordance with aircraft ground support equipment – basic IATA AHM, IATA IGOM safety requirements.
- Catering vehicle must not move towards the aircraft until the aircraft has come to complete stop, chocks positioned, engines shut down, the aircraft coned and the anti-collision beacons switched off.
- On approach and positioning of a catering vehicle, the vehicle should be positioned to the service doors R1 and/or R2 where available.
- The service doors can be opened safely from inside of the aircraft. Crew members and maintenance staff are responsible for door operations.
- Before removing catering vehicle from any aircraft cabin service door, the driver must advise the cabin crew.
- Elevating devices must not be driven in the elevated position.
- Extension platforms or bridges should be engaged and locked in place.
- The guard rails need to be extended till the door frame (both sides) to avoid any FOD getting sucked into the APU inlet.
- If cabin crew are on board during the catering load process, they shall take necessary precautions to prevent loose catering items from being blown into the APU and/or outside onto the apron (E.g. warn caterer about carrying loose light weight items such as plastic bags, bottles etc.) Cabin crew shall also take the same preventions inside the galley areas.

- During fueling with passengers on board catering is not allowed.
- Catering vehicle movements must be guided by an agent using standard IATA signals, and/or assisted by means of a rear-view video or mirror.
- Do not drive or park under the aircraft fuselage and/or wing.
- Catering uplift without vehicle must be done at Pax door before Pax embarking or after Pax embarking.

**Security:**

- Security check of catering loaded on the aircraft is under the responsibility of Cabin Crew.
- Supervision and packaging of catering products at the production point are under the responsibility of the catering supplier.
- Trolleys containing the catering materials and sales products to be taken in to the aircraft must definitely be closed with Security Seals at the preparation point by the supplier company.
- While catering and sales trolleys are being loaded onto the aircraft, Cabin Crew checks to ensure that security seals are existing and in good condition. Trolleys that haven't been sealed or trolleys that have tampered seals shall be returned to the Caterer.

**3.6. ADVERSE WEATHER CONDITIONS**

- Adverse or poor weather conditions may have a negative impact on aircraft handling activities and ground safety.

**3.6.1 Winter or Slippery Apron Conditions**

- Winter weather brings extra hazards which require awareness and more care on the part of personnel working on the aprons to prevent accidents. The following precautions to reduce accident risk must be taken:
  - i. Plan additional time for all ramp activities and take extra care when walking across apron surfaces which can be slippery.
  - ii. Take extra care when driving, especially approaching the aircraft. Remember that vehicles require greater distance to stop safely.
  - iii. Operators of potable water tankers and toilet servicing vehicles must be vigilant that there is no spillage or leakage that can lead to subsequent freezing. Care must be taken to keep spillage and overflow to a minimum.
  - iv. Close all entrance and cargo hold doors as soon as possible and keep them closed to avoid precipitation or snow entry into the aircraft.
  - v. Reduce speeds in slippery apron conditions. Adjust all activities and operations on the ramp to suit the conditions at the time.

**3.6.2. Thunderstorms**

- Refer to local airport or operating airline policy. Thunderstorm communication may be implemented in alert phases and the following represents a minimum standard.



*Do not wear a headset connected to the aircraft during a thunderstorm or if a warning has been issued. When lightning is present:*

*(a) Do not communicate with the flight deck using a connected communication headset. If necessary, communicate using standard hand signals as shown in this chapter.*

*(b) Do not stay in open areas, under the aircraft loading bridge or near any pole.*

*(c) Stop all ground handling operations.*

- Aircraft fueling must immediately be stopped and is prohibited during thunderstorm activity.

**3.6.3. High Wind Conditions**

- High winds pose a great risk of damage and the following minimum precautions should be taken:
  - i. Ensure the safety of the aircraft by installing additional chocks and removing all equipment from around the aircraft.
  - ii. Take extreme care when opening or closing aircraft hold doors.
  - iii. Make sure parking brakes are set on all parked GSE.

- iv. Set parking brakes and secure by additional means if necessary, all non-motorized ramp equipment.

- **High Winds Activity Table**

- The actions stated IGOM 3.3.5 shall be taken when sustained winds and/or gusts of wind exceeding 25 KTS or greater are predicted.

### 3.6.4 Storms-Lightning

#### 3.6.4.1 Storm-Lightning Work Instructions

On receipt of an ALERT:

- Make preparations for the STOP phase.

1. Suspend non-essential activities in open areas and ensure any staff using or about to use headsets are informed of the alert.

2. Fueling operations can continue, however the proximity of the thunderstorm/lightning should be continually monitored.

3. Avoid using highly conductive equipment.

- On receipt of STOP

1. Stop fueling. Fueling hoses cannot be left attached to the aircraft during any Thunderstorm/Lighting event

2. Discontinue aircraft communication by head set.

3. Stop all ramp activity and clear ramp

4. Personnel should seek shelter inside buildings or inside metal bodied vehicles. No one should seek shelter under any part of the aircraft, loading bridge, near light poles, fences, under trees.

5. In accordance with local procedures, the aircraft may come on stand but the aircraft doors should remain closed and ground servicing suspended.

#### 3.6.4.2 Lightning Alert Callout

In the absence of an integrated airport notification system, all airside operating staff shall be aware of the following procedures:

- Use the counting method to detect/predict lightning activity. Determine the corresponding level based on the counting method diagram.
- The responsible person notifies all airside operating staff of the lightning alert level. If the person responsible is not available, the counting method should be used by all airside operating staff for self-protection.
- In case of a Red Alert, proceed to a designated shelter.

#### 3.6.4.3 Counting Method

The counting method is used when an integrated airport notification system is absent. It is used to estimate the level of lightning activity.

1. If the counted time is less than 15 seconds, the lightning activity is less than 5 km from the airport.

2. If the counted time is between 15 seconds and 25 seconds, the lightning activity is between 5 and 8 km from the airport.

### 3.6.5 Sandstorms and Low Visibility

The following minimum precautions should be taken:

(a) Issue appropriate Personal Protective Equipment (PPE) such as goggles, masks, covered clothing.

(b) Ensure the provision of shelter, as required.

### 3.6.6 Intense Heat

The following minimum precautions should be taken:

- (a) Issue appropriate PPE (i.e., covered clothing)
- (b) Ensure the provision of rehydration for staff
- (c) Ensure the provision of a temperature-controlled environment during rest breaks

### 3.7. SAFETY CONES

- Safety cones are a caution sign for drivers to maintain required safety clearances. Cones protect parts of the aircraft against collision by GSE.



#### 3.7.1. Safety Cone Placement and Removal

- Prior to arrival of the aircraft, make sure there are sufficient serviceable safety cones to protect the aircraft type to be handled.
- Do not approach the aircraft to position cones unless all of the following criteria are met:
  - i. Aircraft has come to a complete stop.
  - ii. Engines have been shut down and are spooling down.
  - iii. Anti-collision lights are switched off.
  - iv. Aircraft has been chocked.
- Place safety cones on the ground in accordance with the diagrams, see IGOM 4.3.2—within a maximum of 1 meter outward from the point of the aircraft being protected. Cones must not be placed in high wind conditions.
- Since 737-800 MAX aircraft are equipped with sharklets/winglets, three cones need to be placed at the wingtip area to enhance the visual appearance.
- Additional safety cones may be needed as per operational requirements or local regulations.
- GSE must not approach the aircraft until all safety cones have been placed.
- All required safety cones shall remain in place until GSE and vehicle activities around the aircraft have ceased prior to departure of the aircraft.
- Ensure all GSE has been removed from the ERA.
- Remove the safety cones from around the aircraft.
  - When not in use, place the safety cones in the designated storage area.

### 3.8. AIRCRAFT CHOCKING

#### 3.8.1. Wheel Chock Placement

- Make sure the required number of serviceable chocks are available taking account of the aircraft type and/or weather conditions
- Chocks must be kept clear of the maneuvering area during aircraft arrival
- Do not approach the aircraft to position chocks until the aircraft has come to a complete stop
- One designated member of the ground staff immediately places chocks forward and aft (if aircraft type allows) of the nose gear. This is the first action to take place around the aircraft, and shall be completed before any other activity may take place.
- Before approaching the main gear, wait until:
  - i. Engines have been switched off and are spooling down.
  - ii. Anti-collision lights are switched off.
- Place chocks forward and aft of the main gear in accordance with the applicable normal chock placement diagram. The chocks should lightly touch the tires.



- Notify the flight deck crew that the chocks are inserted
- Walk towards the main gear in a path parallel to the fuselage.
- Remove any temporarily-placed nose gear chocks, if applicable.
- Give the 'Chocks Inserted' hand signal to the flight deck crew.

### 3.8.1.1 Chocks inserted

With arms and wands fully extended above head, move wands inward in a “jabbing” motion until the wands touch.



## 3.9. HAND SIGNALS

### Introduction

- In order to standardize “ground staff–ground staff” communication and/or “ground staff–flight crew” communication, the following hand signals are defined:
- **Guide Man Hand Signals**–to be used by a specific guide man in direct liaison with the equipment operator to facilitate movements of any type of GSE.
- **Marshalling Hand Signals**–to be used by ground staff, to assist the flight crew during maneuvering of the aircraft and engine starting.
- **Technical/Service Hand Signals**–to be used by ground staff to communicate technical/service information to flight crew, and by flight crew to communicate technical/service information to ground staff.
- **Pushback Hand Signals**–to be used during the tractor/towbar connection/disconnection process, and at the start and end of the pushback operation.

### 3.9.1. Conditions for Using Hand Signals

- The person giving the hand signals must:
- Use only approved hand signals.
- Be clearly identified to avoid any possible confusion.
- Maintain the same role throughout the procedure.

- Keep in constant, visual contact with the other ground staff and flight crew throughout the maneuver. If visual contact is lost, the operation must stop and not re-commence until visual contact is re-established.

**3.9.2. Guide Person Hand Signals (For Ground Service Equipments)**

- Please see the IGOM Chapter 3.4.4

**3.9.3. Marshalling Hand Signals (For Aircraft)**

- Do not perform aircraft marshalling unless it is permitted by the local airport authority and you have been trained and authorized.
- Give marshalling hand signals from a position forward of the aircraft while facing and within view of the pilot.
- Use illuminated torch lights/wands to improve the visibility of the hand signals in the following situations:
  - i. Insufficient apron lighting
  - ii. Poor visibility
  - iii. Night conditions
  - iv. When required by local Airport Authorities or regulations.



*To avoid any possible confusion by the Flight Crew, do not use guide man hand signals for equipment until all aircraft marshalling has been completed.*

*Please see the detailed information in IGOM Chapter 3.4.7 for Marshalling hand signals*

**3.9.4. Technical/Service Hand Signals—Ground Staff to Flight Crew**

- Only use manual signals when verbal communication is not possible.
- Make sure acknowledgement is received from the flight crew on all occasions.  
Please see the detailed information in IGOM Chapter 3.4.8

**3.9.5. Technical/Service Hand Signals—Flight Crew to Ground Staff**

- Please see the detailed information in IGOM Chapter 3.4.9

**3.9.6. Aircraft Movement Hand Signals—Headset Operator to Tug Driver**

- Please see the detailed information in IGOM Chapter 3.4.5

**3.9.7. Aircraft Movement Hand Signals—Wingwalker to Headset Operator/Tug Driver**

- Please see the detailed information in IGOM Chapter 3.4.6

**3.10. AIRCRAFT ARRIVAL****3.10.1. Actions Prior to Arrival**

- Conduct FOD check on entire stand and removing all debris just prior to arrival.
- Make sure the stand surface condition is sufficiently free of ice, snow, contamination etc., to ensure safe aircraft movement.
- Personnel not involved in the aircraft departure are positioned outside the equipment restraint area
- Make sure that the required Ground Support Equipment (GSE) is positioned well clear of the aircraft path, outside the Equipment Restraint Area (ERA).
- Make sure the aircraft path and ramp area is free of objects and obstacles which the aircraft may strike or endanger others due to jet blast effects.
- Make sure aircraft docking guidance system is operating, or marshalling staff is present.
- Make sure additional ground personnel (such as wing walkers) are present (if required).

*All persons not responsible for the aircraft arrival operation must stay well clear of the arriving aircraft and must not approach the aircraft until:*



- *The engines have been switched off and are spooling down.*
- *The anti-collision lights have been switched off, and*
- *The main gear wheel chocks are positioned.*



- *Clearance to approach the aircraft has been given by the agent responsible for the arrival operation, if applicable.*

Prior to the arrival of the aircraft, the following equipment must be serviceable and available on the stand:

- Chocks (as required by aircraft type)
- Safety Cones (as required by aircraft type)
- Ground power (as required)
- Preconditioned air (as required)
- Headset interphone (if applicable)
- Day or night wands (whichever is applicable)

### 3.10.2. Standard Arrival Procedure

#### ➤ Aircraft Arrival at a Stand or Open Ramp

- For a standard arrival procedure at a stand without an automated guide-in system or at an open ramp:
  - As aircraft approaches the stand area, the marshaller points to the guide-in line on the ramp to be followed by the aircraft by standing at the top of the guide-in line and giving the "IDENTIFY STAND" signal.
  - While the aircraft taxis along the guide-in line, the marshaller gives the "Continue to Taxi ahead" signal with marshalling wands.
  - The nose wheel should follow the lead-in line all the way to the appropriate stop point. Use the "Turn Left" or "Turn Right" signals to correct the track of the aircraft as required.
  - If at any time during aircraft movement you are unsure or identify an imminent danger, STOP the aircraft.
  - As the aircraft approaches the stop position, use the "Slow Down" signal if required. As the nose wheel reaches the stop point slowly cross the wands in the "Stop" signal.
  - Once the aircraft has come to a complete stop and all conditions for chocking are met, the aircraft can be chocked.
  - Ground power and Pre-Conditioned Air are connected (if required/available).

### 3.10.3. Actions after Arrival

#### ➤ Upon aircraft stopping:

- Position wheel chocks at nose landing gear wheels. (if required)
- Position and connect the Ground Power Unit, if required, before engine shut down.
- Vehicles and personnel remain clear of parking stand until engines are shut down and anti-collision lights are turned off.

**After engines have been switched off, are spooling down and anti-collision lights have been switched off:**

- Position wheel chocks at the main landing gear wheels and verbal/visual confirm to flight crew.
- Confirm there is no damage on the cabin door area prior to positioning the passenger boarding device(s).
- Position the safety cones.
- Conduct an arrival walk around to inspect for damage on the following parts of the aircraft:
  1. All cargo doors
  2. All access panels and servicing access points
  3. Aircraft fuselage
  4. Aircraft engine cowlings
  5. Aircraft passenger doors.

- Give clearance for GSE to approach aircraft.
- This walk around check and security check after arrival will be observed on a sampling basis.



**Note:** If any damage is found, report it immediately to supervisor and do not approach the aircraft with any GSE in the area where the damage has been found.

**Caution:** If an aircraft arrives with an unserviceable anti-collision light, do not approach the aircraft until headset communication has been established with the flight crew.

### ➤ Ground Support Equipment on Arriving Aircraft

#### • Ground Power Unit (GPU)

(a) It is permitted to pre-position a GPU inside the ERA provided there is an assigned GPU parking position.

(b) Position the GPU on the appropriate side of the nose parallel to the aircraft center line with the towbar facing away from the aircraft as shown below.

(c) Set parking brake/chock the GPU.

### ➤ Cooling/Heating Units/Pre-Conditioned Air (PCA)

- Before supplying air by external source make sure that at least one cabin door is open and remains open during air unit operation as per operating airline procedure.
- Make sure that a motorized ground air supply unit is not near the aircraft. The engine exhaust pipe of the unit **MUST** point away from the aircraft. Heat from the unit's exhaust can cause damage to the aircraft structure.
- As part of the fuel conservation programs of most airlines, pre-conditioned air is required at all airports that provide on-stand preconditioned air.
- Refer to the operating airline's manual for the specific aircraft type for the location of the PCA access panel on the aircraft.



**Note:** Make sure there is no blockage of the hose.

#### • To connect PCA:

(a) Open access panel.

(b) Connect ground pre-conditioned air unit to aircraft.

(c) Start up ground pre-conditioned air unit.

(d) On the ground pre-conditioned air unit, select the desired cooling or heating settings (air temperature and flow rate) or position the selector in the appropriate position.

#### • To disconnect PCA:

(a) Shut down ground pre-conditioned air unit.

(b) Disconnect ground pre-conditioned air unit from aircraft.

(c) Close the access panel.

(d) Retract the PCA hose to the fully stowed and secured position.



### 3.10.4. Turnaround Timeline and Phase Management

This section establishes the standard turnaround timeline for ground handling operations. The target timeline is designed to support on-time performance (OTP); however, safety, security, aircraft limitations, regulatory requirements, and flight crew instructions shall always take precedence over turnaround targets.

**0–5 Minutes | Arrival Stabilization**

- Chocks installed immediately upon aircraft stop
- Aircraft safety check completed
- GPU connected
- Required GSE positioned
- Initial turnaround briefing initiated

Immediately after aircraft stop and chocking, the assigned ramp team shall complete the initial safety and service preparation phase without delay. Any delay during this phase constitutes a direct OTP risk and shall be immediately communicated to the responsible turnaround coordinator.

**5–15 Minutes | Arrival Service and Offload Phase**

- Baggage offload initiated and progressing steadily
- Disembarkation underway
- Water, catering, toilet, and cabin services initiated
- Cabin crew and PIC briefing completed

Disembarkation, baggage offload, and applicable aircraft servicing activities shall be carried out in parallel wherever safety permits. Crew coordination and the turnaround briefing shall be completed during this phase to avoid delays to the subsequent loading and boarding process.

**15–25 Minutes | Critical Servicing and Loading Transition**

- Fueling initiated and ongoing
- Interior cleaning in progress
- Baggage loading commenced

The turnaround shall transition from arrival handling to departure preparation. Fueling, interior cleaning, and baggage loading shall be coordinated to prevent avoidable waiting time between offload completion and departure loading. A qualified person shall continuously supervise all loading activities.

**25–35 Minutes | Boarding and Document Preparation Phase**

- Boarding initiated
- Load sheet and departure document preparation proceeding in parallel
- No last-minute waiting for documentation

**35–41 Minutes | Final Preparations**

- Boarding in its final phase
- Loading completed
- Departure documents and load sheet delivered

By minute 41, baggage loading, loading confirmation, and departure document readiness shall be completed to the greatest extent operationally possible. Any expected delay affecting boarding completion, load sheet finalization, or hold closure shall be escalated immediately to all concerned parties. Re-opening of any closed hold or cabin door shall be avoided unless operationally essential and authorized in accordance with the relevant GOM procedures.

**41–45 Minutes | Final Departure Phase**

- Hold doors closed
- Cabin doors closed
- GSE removed
- Walk-around completed
- Chocks removed
- Pushback ready

The final five minutes of the turnaround shall be treated as a protected departure phase. Hold closure, cabin door closure, GSE removal, final walk-around, chock removal, and pushback readiness shall be

completed under the supervision of the responsible operations agent. No non-essential interruption shall be permitted during this phase.

### 3.11. AIRCRAFT DOORS

- Do not operate **ANY** aircraft doors unless you have been authorized to do so. Only Crew members and Aircraft Engineers authorized to operate Cabin access doors of Corendon Airlines Aircrafts.
- Seek assistance from maintenance personnel if any difficulty is experienced during normal door operation.
- During the opening and closing of aircraft cabin doors, please make sure that GSE or a passenger boarding bridge:
  - Is positioned at a cabin access door prior to door opening.
  - Remains positioned at a cabin access door at all times when such door is open unless an appropriate fall prevention device is placed across the open door
  - Is removed from a cabin access door immediately after such door is closed.

*Caution: Do not operate or leave doors open in winds exceeding those indicated in the manufacturer's limitations.*

#### 3.11.1. Cabin Access Doors

- Cabin access doors shall only be in open position if there is an appropriate boarding device positioned at the door.
- Cabin access doors may not be opened without appropriate equipment positioned at the door.
- Slide deployments can be fatal. If an armed door begins to open, do not attempt to hold the door, as you risk being seriously injured or killed.
- If a cabin access door is found open without a boarding device positioned at the door you must immediately notify a supervisor or the Corendon Airlines representative.
- Guard the cabin access door until a qualified person is present to close it.

##### ➤ Opening Cabin Access Doors

- Please contact with crew or aircraft engineer to open the cabin access doors.

Ground staff should:

- (a) Knock at least twice on the door from outside to indicate that a boarding device is properly positioned outside a door to be opened and that the door swing area is free of obstructions.
- (b) Stand clear of the door and wait for the cabin crew or authorized person to open.
- (c) Do not assist cabin crew with moving the door to the fully opened position and engaging the gust lock.

##### ➤ Embarkation or Disembarkation through Cabin Access Doors

- Before allowing passengers or crew embarkation or disembarkation via a cabin access door, ensure that the boarding device is properly positioned at the door, and if stairs or integral airstairs are to be used, that both guard rails (if applicable) are extended.

##### ➤ Closing Cabin Access Doors

- Make sure service doors are closed immediately after servicing is completed.
- Receive confirmation from the crew that the cabin access door(s) may be closed for departure.
- Before removing the last boarding device from an aircraft, inform any ground staff onboard the aircraft that the last cabin access door is being closed and the last boarding device is being removed from the aircraft.
- Look for any possible obstructions around the door area and remove them.
- Make sure the door gust lock is released.



**Caution:** If the cabin access door cannot be closed with the boarding device connected, then the operation must be performed from inside the aircraft with extra vigilance and without assistance of ground staff outside the aircraft.

- Do not remove the boarding device from the aircraft until the door is fully closed and locked.
- If stairs were used at a cabin access door, then retract the stair handrails if necessary to close the door. Remain at the top of the stair platform until the door is fully closed, and then descend the stairs before they are moved.
- Close the door slowly and carefully in accordance with the instructions and markings labeled on the door, and the respective aircraft type specific instructions.
- Before leaving the vicinity of the door, confirm that the door is properly seated flush with the surrounding airframe and that the exterior door handle is flush with the surface of the door.
- Seek assistance from aircraft maintenance personnel any time a door malfunction occurs.
- Do not retract equipment stabilizers in advance of the cabin door being fully closed.
- Before retracting equipment from the door, check to ensure the maneuvering area is clear of all obstructions and personnel.
- If a passenger boarding stairs unit is used, then retract the passenger stairs canopy. Move the equipment to its approved parking position and engage any applicable restraints (such as closing the door on the passenger boarding stairs opening).
- Make sure that the cabin access door and the surrounding door frame and panels show no visible signs of damage. If damage is discovered during inspection of the cabin access door or frame, then immediately report it to aircraft maintenance personnel, and if available, the Pilot-in-Command.

➤ **Re-Opening Cabin Access Doors**

- If a cabin access door is not closed properly then it must be re-opened and re-closed. Other situations when cabin access doors may need to be re-opened include the following:
  - i. Subsequent delivery of catering and/or supplies, after the passenger boarding devices have been removed, OR
  - ii. Re-connecting of passenger boarding devices after the initial removal. If there is no crew on board the aircraft, please contact with your supervisor or Corendon Airlines Representative.
  - iii. Once the cabin access door has been closed in preparation for departure, do not attempt to re-open any aircraft door without the authorization of the flight crew.
  - iv. If you believe a door must be re-opened, you must notify the flight crew through an open cockpit window or use the flight interphone system.
  - v. If the crew requires a door to be re-opened, they will notify ground staff.
  - vi. Regardless of which party requested that the door be re-opened, once the flight crew gives clearance for the door to be reopened, follow the actions/steps in: Opening Cabin Access Doors.

### 3.11.2. Cargo Hold Doors

➤ **Opening Cargo Hold Doors**

- i. Do not operate cargo doors unless trained and authorized.
- ii. Do not open the cargo doors until the aircraft engines have been shut down and the anti-collision lights have been switched off.
- iii. Before positioning loading equipment or any other ground support equipment at cargo doors and opening cargo doors, perform a visual check for any signs of damage to the doors or surrounding areas. If any irregularities are discovered during this visual check, report them to aircraft maintenance personnel and, if available, the Pilot-in-Command.
- iv. Cargo doors must be opened and closed by using maintenance steps, belt loaders or other GSE. These equipment should have safety rails to prevent falling from height. These safety rails should be raised or extended while accessing, opening and closing the doors.

- v. Open the cargo doors in accordance with the respective aircraft type specific instructions.
- vi. Allow adequate space for door clearance to avoid equipment obstructing the free passage of the door.
- vii. If the cargo door will not open, do not use excessive force, tools or ground support equipment to push or pull on the door to open it. Contact aircraft maintenance personnel for assistance.

### ➤ Closing Cargo Hold Doors

- i. Do not operate cargo doors unless you have first been trained and authorized.
  - ii. Manual operation of an electrically or hydraulically operated cargo door may only be performed by maintenance personnel or flight crew:
- Before closing the cargo doors, ensure: that load restraint and door protection nets are properly fitted;
  - that the cargo compartment lights have been switched off unless required for carriage of AVI;
  - that the door area including the door sill and frame are free of gravel, water, ice and other foreign substances or obstructions;
  - that the door and door frame show no visible signs of damage;
  - that any damage discovered during the inspection of the cargo doors and surrounding areas/frames is immediately reported to aircraft maintenance personnel and the Pilot-in-Command.



*\*Check that door lock indicators are engaged/properly set as applicable and that the door is properly locked, handles are stowed flush and panels are properly closed.*

*\*If a cargo compartment door is not closed properly, it must be re-opened and re-closed.*

**Caution:** *If a cargo door must be re-opened prior to aircraft movement, approval from the flight crew via the ground staff responsible for the departure must be obtained.*

### ➤ Re-Opening of Cargo Hold Doors

- If a cargo compartment door is not closed properly, it must be re-opened and re-closed.
- Once the pre-departure walk around has taken place, do not attempt to re-open any aircraft door without the authorization of the flight crew.
- If you believe a door must be re-opened, you must notify the flight crew through an open cockpit window or use the flight interphone system.
- If the flight or cabin crew requires a door to be re-opened, they will notify ground staff.
- Regardless of which party requested that the door be re-opened, if the flight crew gives clearance for the door to be reopened, follow the actions/steps in: Opening Cabin Access Doors.
- If authorization to re-open the door is not granted, do not attempt to re-open the door unless clearance is received from the flight crew.

## 3.12. AIRCRAFT LOADING

### 3.12.1. Supervision of Aircraft Loading

#### ● General

Before loading, the hold shall be visually inspected for damage that can affect the load capacity.

A qualified individual must supervise the loading of the aircraft and provide a signed confirmation to say:

- i. The aircraft has been loaded as instructed—including any special load instructions;
- ii. The condition of locks, restraints has not affected load capacity;
- iii. The bulk load is correctly secured and locks and nets are in use;
- iv. The holds are free of any foreign objects;
- v. Any deviations are noted.
- vi. Satisfies weight and balance requirements.



### 3.12.2. Safety Requirements Specific to Aircraft Loading Operations

- **General**

- Get assistance when moving heavy articles.
- Do not use baggage carts to gain access to cargo compartments.
- The loader bridge height shall be monitored during the loading process and adjusted as necessary to maintain a correct alignment with the cargo hold floor.
- Block or secure cargo which will not lie flat on conveyor belts.
- Protect live shipments from inclement weather.
- Be alert for special/dangerous goods shipments. Know how they must be handled and secured.
- Operators of equipment shall ensure that other personnel are not entrapped by movement of load/pallets/containers either in the aircraft or on the loading equipment.
- Gates of loaded carts should be lowered carefully, in case loose cargo falls out and causes injury.
- Holds and compartments shall only be entered or exited by using the appropriate elevating device and which has been positioned and secured, e.g. belt conveyor and cargo loader.
- Do not walk between carts being towed, or when they are stationary on the ramp.
- When loading has been completed, move all loading equipment well clear of the aircraft.

- **Special Precautions when using Carts**

- Do not wedge light packages between heavier items.
- Do not overload. Ensure curtains or restraints on carts are secured while transiting, (if equipped).
- Ensure the overall height of load permits safe lifting of each piece of load during loading and offloading of carts by personnel standing on the ground.
- When using tarpaulins, ensure all straps are securely fastened to the baggage cart.
- When not in use the braking system shall be engaged on all strings of baggage carts.

- **Special Requirements when using Tractors**

- Drive tractors and carts within speed limits according to local airport regulations, and take care to avoid sharp turns, jerks and sudden stops.
- Approach the aircraft at walking speed 10km/h max.
- Limit the number of carts and dollies in a train to the maximum specified by the local airport regulations.
- Do not attempt sharp turns close to the aircraft. Keep at least 1 m (3 ft.) away from the fuselage.

- **Special Precautions when using Belt Loaders**

- Ensure proper separation between articles on the conveyor belt to avoid jamming.
- Adjust the back of the conveyor belt correctly to avoid dropping goods from the belt.
- Handrails shall be deployed when a belt loader is used to gain access to aircraft cargo holds; however, caution shall be exercised where there is restricted clearance with the aircraft fuselage or engines.

- **Low-Wing Aircraft (B738)**

- To prevent damage to aircraft with low wings, baggage tractors shall stop approximately 1 meter (3 ft.) from the belt loader to unhook the carts. Move the tractor away and position the carts by hand.
- Take care when pulling or pushing carts especially when ramp conditions are slippery. When necessary obtain assistance.

- iii. When removing baggage carts, the tractor shall be positioned pointing away from the aircraft wing and the baggage cart pulled to the tractor.
- iv. Extreme caution must be used when using covered baggage carts.

### 3.12.3. General Loading Precautions

- Hold baggage must be inspected for signs of leakage before loading.
- Any item of load which is not properly packed and any item that may damage or contaminate the aircraft must not be loaded.
- Use tarpaulins or covered carts during inclement weather.
- Do not place goods directly on the apron.
- Always observe the specific instruction labels and marks such as FRAGILE, TOP, THIS SIDE UP, etc.
- Report torn (or missing) baggage tags and cargo labels, and do not load unless corrected.
- Report immediately any damage to the load, whether it occurs during handling or is noticed on arrival.
- Report immediately any spills, unusual fumes or smells, etc., to a Supervisor, Flight Crew or local authorities as required.
- Report all loading irregularities [groundoperations@corendon-airlines.com](mailto:groundoperations@corendon-airlines.com) with screenshots.

### 3.12.4. Spills in Cargo Holds

- Spills can occur in cargo holds during loading and in flight due to:
  - i. Improper packaging
  - ii. Damage due to mishandling prior to loading
  - iii. Improper loading in the compartment
- Spills can be liquid, gels, or material in a powdered or granulated form.
- Spills can be hazardous corrosive, flammable, explosive, toxic or poisonous, etc. Even water can cause serious damage to electrical components and systems.
- Spills can be corrosive to the aircraft structure. Mercury spills are particularly corrosive to the extent that the affected aircraft structure may have to be completely replaced if not cleaned up quickly.
- It is essential that any spill is reported immediately to Maintenance, so that corrective action can be taken.

### 3.12.5. Cargo Hold Inspection

- Prior to commencing the loading of the aircraft, a visual check of ALL cargo holds must be conducted for:
  - i. Damage to the compartment
  - ii. Damaged or malfunctioning floor locks
  - iii. Spills in the hold that may have occurred
  - iv. Baggage or cargo that may have been left onboard the aircraft.
  - v. Any other items that should not be present in the hold
- A check must be conducted in a hold even if on arrival the hold was reported as not carrying any cargo/baggage (empty).
- If any damage is found to the compartment or locks, if a spill has occurred, or if any other irregularity is found, it must be immediately reported to a supervisor, the flight crew, and/or a company representative as required by Corendon Airlines.
- **Cargo Hold Damage**
- Any damage to the structure or linings of containerized or bulk holds may lead to specific loading limitations. Therefore, any damage must be reported. The Load Controller shall be informed accordingly.

### 3.12.6. Compartment Separator Nets

- Compartment separator nets must be secured prior to all flight departures.

- Between offload and onload, compartment nets must be secured inside aircraft compartments and not left hanging outside, to avoid clips and attachment points from striking fuselage (especially during adverse weather conditions) or inadvertently hooked on GSE and pulled out of the aircraft.
- **Cargo Door Barrier Nets**
- Cargo door barrier nets must be installed prior to flight departure to prevent cargo from shifting in flight and damaging or blocking the compartment door.

### 3.12.7. Aircraft Ground Stability

- Loading or offloading may cause the aircraft to become unstable or could cause the aircraft to tip. Respect aircraft ground stability requirements during loading and offloading. In general:
  - i. offload aft holds before forward holds
  - ii. when loading, load forward holds before aft holds

### 3.12.8. Offloading Procedure

#### ➤ Actions Prior to Unloading

- Comply with any safety and special handling requirements. All shipments requiring specific handling will be identified on the LDM/LIR.
- Verify the arriving aircraft registration with the registration on the LDM/LIR
- Offloading should start from Hold 4 to Hold 1 in sequence.
- Offloading should start with Mobility devices, AVIH, Priority bags, Buggies, regular bags and cargo in sequence.
- Make sure that packages with directional handling labels are kept in the correct orientation.
- Take care with fragile items.
- Ensure the necessary equipment for unloading is available on the aircraft parking stand.

#### ➤ Actions During Unloading

During unloading, the person responsible for the aircraft loading supervision task shall:

- Cross-check the ULD/load against the LDM/LIR as the unloading progresses to ensure the correct sequence of unloading takes place in accordance with the specified timelines.
- For bulk unloading:
  - Perform a visual inspection of all items during unloading to ensure no damage/leakage.
  - Ensure the load distribution is in accordance with the LDM.
- Ensure special equipment (e.g., tie-down straps, load spreaders, plastic sheeting for wet cargo) is unloaded.
- Log any irregularities in the unload sequence noted during unloading and report to Corendon Airlines Ground Operation Department.
- Ensure, where applicable, transit loads are not offloaded or over-stowed.

#### ➤ Actions After Unloading

After unloading has been completed, the person responsible for the aircraft loading supervision task shall:

- Carry out a hold inspection, in accordance with IGOM 4.5.5.1 and GOM 3.12.5.
- Ensure the nets and straps are properly stowed and cargo access door checks are performed in accordance with IGOM 4.4.3 and GOM 3.11.2 in case the cargo access doors need to be closed.
- Sign the LIR if applicable and in doing so confirm that:
  - Aircraft has been unloaded in accordance with LIR
  - Load was unloaded in a manner that prevents damage or spillage.
- Close the cargo access doors if the aircraft is to be left unattended.
- If irregularities are reported during the unload sequence report to Corendon Airlines Ground Operation Department.

#### ➤ Safety Precautions for Offload

- Take care when handling heavy items. Use proper lifting techniques and ask for assistance if required.
- Take care when placing items on belt loaders. Make sure they are stable and will not fall off.
- Take care if load has shifted during flight.
- Containers can tip during movement because the base is smaller than the top, causing a high center of gravity.

### 3.12.9. Loading Procedure

- Standard Loading Procedure for Corendon Airlines
  - i. Standard loading one-sector flights
  - ii. 1/3 of total load (in pieces) in hold 2, if rest in hold 1;
  - iii. 2/3 of total load (in pieces) in hold 3, if rest in hold 4;
  - iv. Manual wheelchairs and buggies in hold 4 then 3;
  - v. Priority labeled baggage in hold 4;
  - vi. Loading sequence: Loading should start from hold 2, then 1, then 3 and then 4 in sequence.
  - vii. Ideal CG needs to be between 22-24.
- Standard loading two-sector flights
  - viii. 1/3 of total load (in pieces) in hold 2, if rest in hold 1;
  - ix. 2/3 of total load (in pieces) in hold 3, if rest in hold 4;
  - x. Manual wheelchairs and buggies in hold 4 then 3;
  - xi. Priority labeled baggage in hold 4;
  - xii. Loading sequence: Loading should start from hold 2, then 1, then 3 and then 4 in sequence.
  - xiii. Ideal CG needs to be between 22-24.
- Standard loading three sector flights
  - i. Distribute baggage and cargo evenly over the holds;
  - ii. Loading to be started from forward hold to aft hold;
  - iii. Baggage of heaviest leg in hold 3, if rest in hold 4;
  - iv. Baggage of lightest leg in hold 2, if rest in hold 1
  - v. All involved stations must inform each other regarding embarking and disembarking passengers and their baggage;
  - vi. Manual wheelchairs, buggies and priority labeled baggage of lightest leg in the doorway of cargo door 1 (Crew bags if applicable), those of the heaviest leg in doorway of cargo door 2;
  - vii. First load Hold 2 and then 3;
  - viii. An SI shall be added in the AD MVT MSG about loaded wheelchairs, buggies and priority labeled baggage.
  - ix. Ideal CG needs to be between 22-24.
- Before loading commences, verify the aircraft registration with the registration on the loading instruction report.
  - i. Ensure special equipment (tie down straps, etc.) is available, as required.
  - ii. Ensure LIR is received and understood by loading crew.
  - iii. Before loading commences, carry out inspection of cargo compartments and restraint system. Report any defects to supervisor, the flight crew, and/or a company representative as required by Corendon Airlines.
  - iv. For cargo shipments, ensure the nets or tie down straps are tight and the load is secure.
  - v. Items with directional handling labels should be loaded so that the labels will be visible during offload.
  - vi. Ensure separator nets, fire barriers, door nets, pallet locks and container stops are installed and locked as required as the hold is loaded.

- vii. Keep count of bulk loaded baggage by compartment and destination.
- viii. Ensure the aircraft is loaded in accordance with written loading instructions;
- ix. Ensure the load is secure and will not move during the flight.
- x. Document all changes to the load and sign the Load Instruction Report.
- xi. Carry out load verification prior to finalizing the weight and balance.



All baggage, parcels and other forms of cargo must be loaded such that there is **a 2-inch minimum clearance** from the ceiling to permit airflow to smoke detectors and fire suppression agent distribution. Limited intrusions, such as corners of luggage are acceptable provided they are not directly below the smoke detectors or fire suppression nozzles.

#### ➤ Human Remains in Coffins (HUM)

- The corpse must be in a hermetically sealed metal casket/zinc, lead, bronze). The casket must be put into a strong wooden coffin which must be wrapped up in hessian. All necessary documents must be fixed on top of the coffin. The coffin must be loaded in a horizontal position.
- It is not allowed to load the coffin close to edible materials (EAT) or food for human consumption (PES/PEM/PEF) Human remains in coffins should not be loaded in close proximity to animals (AVI) or live human organs/human blood.
- **It must be loaded in hold 3 or hold 4.** If loading into the **forward hold** is required, **Captain approval must be obtained.**

#### ➤ Live Animals

- Transportation must be in accordance with the IATA Live Animals Regulation (LAR).
- Generally, transportation of animals in the cargo compartment of the aircraft is permitted under following conditions:
  - i. All live animals shall only be loaded in the prescribed compartments. Live animal shipments shall generally be treated as wet freight.
  - ii. AVI must be loaded in upright position.
  - iii. The cages shall always be tied- down or lashed in order to avoid any kind of movement at take-off loading and during flight.
  - iv. The cages shall not be loaded directly in front of air ventilation outlets or contact in with the outer compartment walls.
  - v. The cages shall be stowed in such a way that there is enough distance to other cages and other load to guarantee a sufficient oxygen supply.
  - vi. Compartments lights shall generally be switched off
  - vii. The corresponding compartment door shall be closed as late as possible. At the destination or transit station the compartment door shall open promptly this procedure applies also to the technical landings.
  - viii. The animal shall be kept in an appropriate area airside until loading. Depending on the environmental conditions, this area may be enclosed, heated, etc. so the animal does not suffer discomfort.
  - ix. Minimize time on the ramp to protect animals from wind, rain, noise and extreme temperatures.
  - x. Animals should be loaded last and unloaded first.
  - xi. Keep other luggage at least 15 cm (6 inches) away from the container sides to maximize ventilation.
  - xii. Do not load animals in the same compartment with dry ice, perishable cargo and/or HUM.
  - xiii. Take the deplaning animals immediately to the terminal for claim by their owners.
  - xiv. Never use the baggage chute to deliver an animal. If the animal cannot be immediately claimed, take the animal to a climate controlled waiting room.

xv. Before loading, handling staff shall inform the PIC about the nature, location and conditions of live animal load via "Special Load–Notification to Captain" (NOTOC).

- Always, prior to transportation, authorization by Corendon Airlines SITA Addresses (AYTOP7H) shall be obtained. In exceptional cases, duty the station manager can give this permission.



*AVI may load to Hold1 and Hold2 for Corendon Airlines aircrafts.*

*A maximum of 4 PETC may be transported in the passenger cabin of an aircraft and maximum of 4 AVIH may be transported in cargo holds. Maximums can be extending by the PIC's decision.*

*Temperatures in compartments depend on initial temperatures and flight time is valid for the whole compartment except the door area where temperatures are slightly lower.*

### ➤ Tie Down

- Loose load is usually restrained by separation nets between sections or door protection nets. Nevertheless, certain type of loads must always be tied-down.
- The following is an example of items which must always be tied-down:
  - i. All high density packages (sharp angles, steel extrusions, metallic trunks, etc.).
  - ii. Power driven wheelchairs (bulk compartment).
  - iii. AVI.
  - iv. Human remains (HUM).

### ➤ Load Spreading

When the weight of item(s) to be loaded exceeds the maximum floor load per square meter or the maximum floor load per running meter of a compartment, the weight must be spread to prevent damage to the compartment floor. This applies to HEA loads but may also apply to smaller items weighing less than 150 kg (330 lb.). The item must be fully restrained (see IGOM 4.5.8) and can be spread by making use of wooden boards or beams.

**Caution:** Overloading can cause damage to aircraft frames and ribs and consequently can have serious implications for the safety of the aircraft.

The weight should be spread by making use of wooden boards or beams, in which case:

- a. The surface to support the weight will be enlarged, or
- b. The length will be enlarged

## 3.13. AIRCRAFT DEPARTURE

### ➤ Introduction

- A departure is normally conducted with a dialogue between flight crew and ground staff in charge of the departure via an interphone. This procedure ensures the highest level of safety during departures based on a precise exchange of information.
- The person responsible for pushback is in charge of the departure operation remains in continuous contact with the flight crew and is responsible for the ground maneuver. The scope of this departure procedure is limited to conventional towbar and towbarless pushback operation.



**Note:** The term "headset" also applies where an interphone system is used.

### 3.13.1. Wheel Chock Removal

- Headset Operator:
  - i. Via the interphone, request chock removal approval from the flight crew, and confirm the aircraft parking brakes are set
  - ii. Check all GSE have been disconnected from the aircraft

- iii. Check the passenger boarding stairs have been retracted from the aircraft, if applicable
- iv. Check the tow tractor and tow bar (or towbarless tractor) are fully secured to the nose gear and parking brakes are set on the tractor, if applicable
- v. Give clearance to ground staff to remove chocks.



**Note:** If a chock is stuck, the responsible personnel remove it by tapping it with a spare chock or moving the aircraft after the aircraft brakes have been released.

- vi. (f) Relay 'Chocks Removed' hand signal to the flight crew, and ensure the flight crew repeats the 'Chocks Removed' hand signal as a confirmation
- vii. (g) The responsible personnel shall stow chocks in their designated stowage place.



**Note:** Nose gear wheel chocks may be removed without notification provided the main gear wheel chocks are still positioned. Once high wind or icy conditions have passed, any additional chocks that were added to the aircraft may be removed so that chock placement reverts to that for normal conditions.

- If hand signals are used (i.e. aircraft interphone system is inoperative) the person performing the hand signal must:
  - i. be in continuous visual communication with the flight crew throughout the pushback
  - ii. display the 'Set Brakes' hand signal
  - iii. receive confirmation from the flight crew when they display the 'Brakes' hand signal in response
  - iv. display the 'Chocks Removed' hand signal
  - v. Receive confirmation from the flight crew. Do not remove chocks until confirmation of the flight crew is received

### 3.13.1.1 Chocks Removed:

With arms and wands fully extended above head, move wands outward in a "jabbing" motion. DO NOT remove chocks until authorized by the flight crew.



### 3.13.2. Action Prior to Departure

- Prior to departure of the aircraft, make sure that:

- i. the ramp area is clear of all FOD and any equipment;
  - ii. the apron surface condition is sufficiently free of ice, snow, contamination etc., to ensure safe aircraft movement;
  - iii. the ramp area is free of objects/obstacles which may be impacted by the aircraft or may endanger others due to jet blast effects;
  - iv. all persons not involved in the aircraft departure operation must remain clear of the departing aircraft, behind the ERA;
  - v. additional ground staff such as Wing Walkers are present (if applicable/required);
  - vi. If applicable, communication with the flight crew is established on air start procedures with air starter unit (ASU);
  - vii. Use of anti-collision light(s);
  - viii. Communication with flight crew is established by means of an interphone system, departures using marshalling hand signals without any headset communication are only conducted in exceptional cases.
  - ix. Vehicles and personnel remain clear of aircraft engine intake and/or blast areas during engine start
  - x. Any abnormalities, (obvious damage, fluid leakage, damage to aircraft skin, flat, damaged, or defective tires or undercarriage oleos, Leaks – Fuel / Hydraulic fluid / Oil / Water etc...) on the aircraft observed are immediately brought to the attention of the PIC and authorized technical personnel. Walk around inspection of the aircraft shall be performed immediately prior to departure for the purpose of identifying, documenting and reporting external aircraft damage
- This walk around check and security check prior to departure will be observed on a sampling basis.



**Note:** Prior to connecting the tractor to the aircraft, the tractor may be parked in front of the aircraft or outside of the ERA, but never behind the wings.

### 3.13.3. Pre-Departure Table

- **General**

“For detailed information and table please refer to IGOM 4.6.3.2 and you may also find related checklist in GOM APPENDIX 12 – Pre-Departure Table”

### 3.13.4. Pre-Departure Check

- **Pre-Departure Walk Around Check**

- The pre-departure walk around check includes, but is not limited to, ensuring the following:
  - i. The apron is clear of all FOD items that may cause aircraft damage or pose a risk.
  - ii. All GSE and passenger boarding devices are detached.
  - iii. The stand area is clear of obstructions. GSE and vehicles are positioned clear of the aircraft path.
  - iv. Adequate clearance exists between the aircraft and facilities or fixed obstacles along the aircraft movement path.
  - v. All aircraft servicing panels and/or hatches are closed and secured (except - external power and headset panels).
  - vi. Cabin/cargo doors are closed and handles are flush with the fuselage;
  - vii. There is no visible damage on the aircraft, particularly around cabin and cargo doors.
  - viii. Any abnormalities on the aircraft observed (e.g. obvious damage, fluid leakage) are immediately brought to the attention of the pilot in command and maintenance.
  - ix. Landing gear safety pins are removed.
  - x. There are no obvious signs of unmarked dents or other skin panel damage.



**Caution:** If any of the above conditions or actions are not met, inform your supervisor, maintenance and the pilot in command. This may affect the safety of the intended flight or airworthiness of the A/C.

### 3.13.5. Communication Requirements

#### ➤ Communication During Engine Start

- Coordinate the engine starting sequence with the flight crew by conducting a pre-departure briefing and refer to the Corendon Airlines' GOM for specific engine start procedures.
  - i. During the engine start communicate with the flight crew only if you observe circumstances that require immediate notification and action by the flight crew.
  - ii. In case of starting up with an ASU, supply the pressure at the request of the flight crew.



**Note:** For ground staff in front of the aircraft, facing the aircraft nose, the aircraft engines are identified, from right to left. (Engine number 1 being the first engine from the right is always on the captain's side).

#### ➤ Communication During Engine Fire

##### • Engine Fire

- The Flight Crew normally detects an engine or APU fire and will take action using the engine fire extinguishing system. However, alert the flight crew immediately via the headset if flames are noticed from the engine or engine pylon.
- In the event that a headset is not available, the appropriate "Fire" hand signal must be used. (Refer to the Marshalling Hand Signals section in this chapter)
- **Tailpipe/Exhaust Fire**
- If you notice flames from the engine tailpipe during engine starting, alert the flight crew immediately, as such a fire might not be detectable via temperature sensors and/or fire warning systems in the aircraft.



**Caution:** Do not fight engine fires with fire extinguishers on the ground when the flight crew is in the flight deck. The flight crew will take all necessary action.

#### ➤ Departure Communication

- Departure communication outlined in this section is a basic standard for both pushback and open ramp (taxi out) departures.
- Corendon Airlines do not have specific requirements in departure communication. IGOM communication standards shall apply.



**Note:** If the pushback must be stopped, the following call will be made: **STOP PUSH BACK**. Where applicable, use "pull out" instead of "pushback". Only engage the towbarless tractor and lift the aircraft once the passenger boarding device has been removed from the aircraft and the flight crew has requested for pushback.

#### ➤ Departure Communication Dialogue

- For details of Communication Dialogue refer to IGOM 4.6.6.2

#### ➤ Items to be Communicated between Ground Staff and Flight Crew

- For details of Communication Dialogue refer to IGOM 4.6.6.3

#### ➤ Departure Communication without Interphone

- An aircraft departure must always be conducted using interphone communications.
- In the event that the interphone becomes unserviceable or under extreme circumstances where the interphone is not available, you must use conventional hand signals (see IGOM 3.4.8 and 3.4.7) for the departure (not applicable to main gear pushback unit departures).
- Prior to departure a briefing must be held between the Captain and the ground agent responsible for the departure, including:
  - i. Review of departure specifics, e.g. direction of movement, final positioning, and taxi out direction;
  - ii. The hand signals to be used, including emergency signals.



**Caution:** Read back all given instructions or acknowledge them in a manner clearly indicating that they have been understood and will be complied with.

### 3.13.6. Preparation for Pushback

- (This section is also applicable to pull-out using applicable equipment)
- **Pre Departure Communication**
- An aircraft departure must always be conducted using interphone communications. In the event that the interphone becomes unserviceable, you must use conventional hand signals see IGOM 3.4.6 and IGOM 3.4.7 for the departure (not applicable to main gear pushback unit departures). Prior to departure a briefing must be held between the Captain and the ground agent responsible for the departure, including
  - i. Review of departure specifics, e.g. direction of movement, final positioning, and taxi out direction
  - ii. The hand signals to be used, including emergency signals



**Caution:** Repeat all given instructions or acknowledge them in a manner clearly indicating that they have been understood and will be complied with.

#### ➤ **Connecting the Pushback Vehicle**

- The pushback vehicle is connected as follows:
  - i. Aircraft main gear chocks installed, nose gear chocks removed—if applicable;
  - ii. Approach nose gear to centerline of fuselage
    - Use a spotter to assist in the final approach to nose gear:
    - 1. Tractor & Towbar:
      - a) Connect towbar to nose gear first.
      - b) Ensure the towbar connection is secured and a locking pin is in place.
      - c) Ensure the tractor and towbar are aligned with the centerline of the aircraft while connecting
      - d) Raise towbar so that its head is at same height as the tractor connection.
      - e) Approach slowly until connection aligns and secure connection to tractor
      - f) Ensure the front wheels of the tractor remain straight and the tractor is in line with the centerline of the aircraft.
      - g) The pushback tractor shall only be connected to the aircraft once all GSE is detached from the aircraft.

**Note:** With the exception of GPU and ASU which may be left connected
      - h) Secure the towbar connection to the pushback tractor.
      - i) Raise towbar wheels by releasing pressure on the hydraulic pump.
      - j) Select “Neutral” or “Park” and set parking brake of tractor
      - k) To minimize the possibility of injury, Ground handling personnel shall:
        - i. Face the tractor when connecting the towbar to the tractor.
        - ii. Stand with both legs on the same side of the towbar during the connection/disconnection procedure
    - 2. Towbarless tractor:
      - a) Ensure the correct aircraft type is selected on the TWL control panel, where applicable and in accordance with TWL operating procedures.
      - b) On final approach to aircraft, the tractor must be properly aligned.
      - c) Ensure the aircraft nose wheels are safely locked into the tractor cradle by the tractor locking mechanism.
      - d) Position Towbarless tractor to standby for lifting and wait for clearance from flight deck to lift and wait for approval from flight deck to lift
      - e) Select “Neutral” or “Park” and set parking brake.

- f) Ensure the aircraft is not lifted while any GSE or PBB are connected to the aircraft.



**Caution:** Do not remove the main landing gear chocks until:

All GSE—with the exception of the boarding passenger stairs(s), GPU, PCA, and ASU is removed from the aircraft, the pushback vehicle is connected to the aircraft and the parking brakes of both the pushback vehicle and the aircraft are set.

#### ➤ Aircraft Pushback

- (This section is also applicable to pull-out using applicable equipment)

#### ➤ Pushback Requirements

- All staff walking on ramp must remain clear of:
  - i. aircraft nose gear throughout the pushback operation;
  - ii. the tractor's path;
  - iii. Engine danger areas.

### 3.13.7. Pushback & Pull Forward

- If an aircraft is to be pulled forward after pushback and engines started, special precautions must be taken to reduce the risk of the aircraft's engine thrust causing damage to the nose gear and towbar when stopping the aircraft at completion of maneuver.



**Caution:** When using a towbarless tractor: Do not lift the aircraft when loading equipment and/or a passenger boarding device is still connected to the aircraft.

#### ➤ Ground Crew in Charge of Pushback

#### ➤ Ground Crew Responsibility

- The responsible ground crew is defined as the person performing the communications with the flight crew.
- A responsible ground crew must be in charge of each aircraft pushback. This function can be performed by different agents in different roles and positions. Refer to the operating airline's GOM for the specific assignment of this duty.
- Responsible ground crew for the departure will:
  - i. be in charge of the entire pushback, once clearance to begin pushback has been given by the flight crew;
  - ii. Make sure that Maximum aircraft nose gear turn limits are not exceeded.
  - iii. Make sure that there is a safe connection, operation and disconnection of the pushback.
  - iv. ensure that the tow bar/shear pin/towbarless tractor is suitable for the specific aircraft type;
  - v. conduct briefings with all persons involved in the aircraft movement to review and confirm how the aircraft will be maneuvered;
  - vi. Standardized communication is used between the ground crew and the flight crew
  - vii. have ultimate responsibility to review pushback procedures based on conditions he/she observes and must inform the flight crew:
  - viii. if ramp conditions are below standard for a normal pushback (e.g. hazards, obstacles, slippery or icy) then:
    1. He/she will inform the flight crew that engine start clearances will not be given until either:
      - (i) the aircraft is moving over an area of the ramp where the conditions are considered to be safe for an engine start; OR
      - (ii) the pushback has been completed, the aircraft has come to a complete stop and the parking brake has been set;

- ix. ensure that the nose gear steering bypass pin is installed prior to tow bar connection to aircraft; connect the interphone and conduct a communication check to:
  - 1. verify the communication system is functional;
  - 2. update flight crew on progress of the ramp operation;
  - 3. request permission & disconnect ground power after verbal approval is received from flight crew.
- x. conduct a Pre-Departure walk around;
- xi. signal "All Clear" to pushback tractor driver and wing walkers (if applicable) once advised by flight crew that the aircraft brakes have been released and approval for pushback given by Flight Crew; be positioned as required by operating airline's GOM, either inside tractor or walking on apron adjacent to nose gear



**Danger:** If walking adjacent to nose gear: walker and tug driver must be in visual contact throughout the pushback. After approval of flight crew, the tugdriver must always assure taxiway is free of other aircraft/equipment/obstacles.

- xii. Monitor the interphone during the pushback and communicate with the flight crew as required; advise the flight crew if for any reason it is not safe to start an engine and stop the engine start (the flight crew may advise as each engine is being started); advise the flight crew to set aircraft brakes at end of pushback. Once confirmation from the flight crew has been received, give the brakes set signal to the tractor driver and wing walkers (if applicable).
- xiii. Give visual signal to the tractor driver and wing walkers (if applicable) that it is clear to disconnect tow bar after flight crew advises that engines were started normally and the ramp is clear to disconnect the tow bar.
- xiv. Disconnect the headset and close the access panel on the aircraft once the approval to disconnect has been given by flight crew and the tow bar has been disconnected.
- xv. Remove the nose gear steering bypass pin (if applicable) and ensure the swing lever is returned to the proper position.
- xvi. After headset, tow bar and steering bypass pin are removed, close and latch all access panels and then move to designated position to conduct final departure marshalling.
- xvii. Show the steering bypass pin to the flight crew and give the "All Clear to Taxi" signal.
- xviii. Give the "All Clear to Taxi" signal once eye contact has been made with the flight crew and they are expecting the signal. In low-light conditions the flight crew will turn on the interior lights of the flight deck.
- xix. Remain in position until an acknowledgement from the flight crew is received and the aircraft begins to taxi



**Caution:** The flight crew (or brake operator) must be notified immediately:

*In the event any connection between the tractor and the aircraft is lost during aircraft movement;*

*To stop the aircraft movement using gentle brake application if the aircraft is about to overtake the tractor while towing.*



**Danger:** If the nose wheels are not in the centered position, they can turn quickly to their centered position when the bypass pin is removed. Personnel injury or aircraft damage could result.

*Do not disconnect the interphone communication cable until the towbar (or towbarless tractor) has been disconnected from the nose gear*

### 3.13.7.1 Power Push Unit with Main Gear Towbarless Tractor

#### Power Push Unit Specifics and Safety Measures

- (a) Before connecting the PPU to the aircraft, it can be parked in front of the aircraft or outside of the ERA, but never behind the wings. Ensure the remote control system is functioning at normal operating distances.
- (b) It is imperative that the driver seat be pulled up, whenever the PPU is connected to the aircraft.

(c) Pushback with a PPU is not permitted in case of an interphone failure.

(d) The agent in charge of the departure operation shall be in permanent intercommunication with the flight

crew. The agent in charge of the departure operation shall stand forward of the aircraft, follow its movements and always be in sight of the flight crew. The agent shall stay outside the engines intake/suction area and wheel path of the aircraft during the entire pushback maneuver.

(e) In case of overpowering the roller jacks' resistance of the PPU due to failure at the end of the pushback operation, it is mandatory:

(i) To ask the material maintenance department for intervention on the PPU.

(ii) To ask the aircraft maintenance department for an inspection of the aircraft.

### **Actions before Pushback with a Power Push Unit**

#### ➤ **Power Push Unit Connection**

Before connecting the PPU:

(a) Inform the flight crew that a PPU will be used.

(b) Refueling shall be completed.

(c) Make sure the NLG is chocked.

(d) Make sure the aircraft parking brake is set.

(e) Remove the MLG chocks.

#### ➤ **Engine Start-up when a Power Push Unit is Used**

The start-up of engine #2 takes place in the normal sequence at the parking stand.

Start-up of engine #1 shall be performed after pushback, with parking brake set, when the agent in charge of the departure operation has moved the PPU to the back of the aircraft stabilizer.

### **Pushback with a Power Push Unit**

Emergency braking during pushback can be performed by:

(a) PPU engine stop (remotely controlled)

(b) Brake application by the flight crew

### **Departure Dialogue when Using a Power Push Unit**

Please see IGOM 4.6.6.4 for the details.

### **Pushback Disconnection**

#### ➤ **Pushback Tractor and Towbar Disconnection Procedures/Requirements**

(a) The responsible ground staff member shall remove the tow pin securing the towbar to the pushback tractor

(b) The pushback driver/operator shall check that other staff are clear of the intended travel path and slowly drive the pushback tractor to a position in the aircraft's path and be visible to the flight crew, if possible, ready for the towbar to be reconnected.

(c) The responsible ground staff member shall disconnect the towbar from the nose landing gear and reconnect to the pushback tractor and move clear of the pushback tractor, in view of the driver/operator.

(d) The responsible ground staff member shall give an 'OK' signal to the pushback driver to confirm that the towbar is reconnected and it is clear to drive away.

(e) The pushback driver/operator shall check that other staff are clear of the intended travel path and slowly drive the pushback tractor to a position visible to the flight crew until the responsible ground staff member on the interphone has disconnected and is in view of the flight crew.

**Note:** Ensure the towbar is disconnected from the tractor before disconnecting from the aircraft (except where the towbar is specifically designed to be disconnected from the aircraft first).

#### ➤ **Towbarless Tractor/Remote Control Tractor Attached to Nose wheel Disconnection Procedure/Requirements**

(a) The pushback driver/operator shall ensure that the tractor wheels are centralized and lower the aircraft nose-wheel and open the tractor cradle.

(b) The pushback driver/operator shall check that other staff are clear of the intended travel path and slowly drive the pushback tractor to a position in the aircrafts path and be visible to the flight crew, ensuring that the wheel cradle is completely clear of the aircraft nose landing gear before commencing a turn.

(c) The pushback driver/operator shall rotate the drivers seat to the 'drive away' direction if applicable.

(d) The pushback driver/operator shall remain in a position visible to the flight crew until the responsible ground staff member on the interphone has disconnected and is in view of the flight crew.

➤ **Power Push Unit Disconnection**

(a) Once the aircraft parking brake is applied with the remote control, the agent in charge of the departure operation controls the opening of the rollers.

(b) With the remote control, the agent in charge of the departure operation controls the move back of the PPU until at least below the tail (beyond the rear cabin door).

(c) Once the aircraft has taxied and the blast risk has disappeared, the agent in charge of the departure operation withdraws the PPU from the taxiway.

**Incidents during Pushback**

➤ **Incidents during Pushback Involving Pushback Tractor/Towbar or Towbarless Tractor**

Flight crew	Tractor Driver
<b>Tractor Failure</b>	
(a) Inform ATC.	(a) Stop aircraft/tractor set.
(b) Apply the aircraft parking brake.	(b) Apply tractor parking brake.
(c) Listen to VHF and wait for assistance.	(c) Inform the flight crew.
(d) Relay information from ATC to headset operator	(d) Contact supervision and equipment maintenance to advise of the situation, as required.
	(e) Follow instructions received from headset operator, as applicable.
	(f) If the TWL/towbar connection with the tractor needs to be reset (i.e., removed and reconnected), the aircraft shall be chocked while the tractor is being replaced.

Flight crew	Tractor Driver
<b>Tractor/Aircraft Separation</b>	
<ul style="list-style-type: none"> <li>(a) Apply the aircraft brakes.</li> <li>(b) As soon as the aircraft is at a standstill, apply the aircraft parking brake before releasing the pedal.</li> <li>(c) Inform ATC.</li> <li>(d) Relay information received from ATC to headset operator, if applicable.</li> </ul>	<ul style="list-style-type: none"> <li>(a) Do not apply tractor brakes.</li> <li>(b) Inform the flight crew of separation.</li> <li>(c) Follow the aircraft path attentively and stop the tractor according to the aircraft position.</li> <li>(d) Apply the tractor parking brake.</li> <li>(e) Confirm the aircraft parking brake is set then chock the aircraft.</li> <li>(f) Assess the reason for the separation.</li> <li>(g) Contact supervision, equipment maintenance and aircraft maintenance to advise of the situation, as required.</li> <li>(h) Follow instructions and/or complete pushback maneuver, as applicable.</li> </ul>
<b>Towbar/Shear Pin Failure (remains attached to the aircraft)</b>	
<ul style="list-style-type: none"> <li>(a) Apply the aircraft parking brake.</li> <li>(b) Inform ATC.</li> <li>(c) Relay information received from ATC to headset operator, if applicable.</li> </ul>	<ul style="list-style-type: none"> <li>(a) Stop aircraft/tractor set.</li> <li>(b) Apply the tractor parking brake.</li> <li>(c) Inform the flight crew of the towbar/shear pin failure.</li> <li>(d) Contact supervision, equipment maintenance and aircraft maintenance to advise of the situation, as required.</li> <li>(e) Chock the aircraft and replace the towbar.</li> <li>(f) Complete the pushback maneuver.</li> </ul>
<b>Pushback Tractor Fire</b>	
<ul style="list-style-type: none"> <li>(a) Inform ATC and headset operator.</li> <li>(b) Apply the aircraft parking brake.</li> <li>(c) Determine the need for aircraft emergency evacuation and confirm to ATC and headset operator.</li> </ul>	<ul style="list-style-type: none"> <li>(a) Inform the flight crew.</li> <li>(b) Stop aircraft/tractor set immediately.</li> <li>(c) Conduct an assessment of the situation and consider tackling the fire with the onboard tractor firefighting equipment only if it is deemed safe to do so.</li> <li>(d) Consider disconnecting and moving the tractor to a safe distance from the aircraft, if deemed safe and appropriate to do so.</li> <li>(e) Contact supervision, equipment maintenance and emergency services to advise of the situation, as required.</li> <li>(f) If flight crew confirm emergency evacuation, assist in the evacuation as far as is possible/practical by directing passengers/crew toward a safe location.</li> </ul>

Flight crew	Tractor Driver
<b>Aircraft Fire</b>	
(a) Inform ATC and headset operator. (b) Apply the aircraft parking brake. (c) Execute onboard emergency procedures.	(a) Stop aircraft/tractor set immediately. (b) Inform the flight crew. (c) If safe to do so, disconnect and move the tractor to a safe distance from the aircraft, where possible. (d) If safe to do so, headset operator should maintain communication with the flight crew and follow instructions. (e) Contact supervision and emergency services to advise of the situation, as required. (f) If flight crew confirm emergency evacuation, assist in the evacuation as far as is possible/practical by directing passengers/crew toward a safe location.
<b>Accident with Other Aircraft or Vehicle</b>	
(a) Contact ATC stating position and nature of the accident. (b) Listen to VHF and wait for assistance. (c) Relay information received from ATC to headset operator, if applicable.	(a) Stop aircraft/tractor set immediately. (b) Apply tractor parking brake. (c) Inform the flight crew. (d) Contact supervision, aircraft maintenance, equipment maintenance and emergency services to advise of the situation, as required. (e) Follow instructions received from the headset operator and/or wait for assistance. (f) Do not disconnect the tractor unless specifically instructed to do so by the headset operator and/or ATC. (g) If disconnecting the tractor, the aircraft must be chocked.
<b>Interphone Communication Failure</b>	
If during the pushback operation the interphone fails, the aircraft must be immediately stopped and an alternate means of communication established before continuing. If this is not possible, assistance must be requested.	
<b>Visual Contact with the Wing Walkers Is Lost (if used)</b>	
In the event that the tractor driver is unable to establish visual contact with one or both of the wing walkers, when used, the pushback shall be stopped and not recommence until visual contact is re-established.	

➤ **Instructions in Case of Power Push Unit Fire During Pushback**

(a) Aircraft on the parking stand, interphone connected.

The agent in charge of the departure operation shall:

1. Warn the flight crew via the ground/aircraft interphone. The flight crew warns the Fire Brigade using VHF.
  2. Controls the release of rollers
  3. If PPU's engine is on:
    - (i) Remove the PPU by remote control.
    - (ii) Remain in contact with the flight crew.
    - (iii) Stop the PPU's engine by remote control, if not automatically.
    - (iv) Leave the interphone contact after consent from the flight crew to fight the fire and report to the flight crew about the on-going situation.
  4. If PPU's engine is off:
    - (i) Leave the interphone contact after consent from the flight crew to fight the fire.
    - (ii) Press one of the three emergency stop buttons (the most accessible).
    - (iii) Tow the tractor away from the aircraft and report to the flight crew about the on-going situation.
- (b) Pushback in progress

The agent in charge of the departure operation must:

1. Inform the flight crew via ground/aircraft interphone. The flight crew warns the Fire Brigade using VHF.
2. Stop the pushback.
3. Request setting of the aircraft parking brake.
4. Control the release of rollers and remove the PPU by remote control.
5. Stop the PPU's engine by remote control, if not automatically.
6. Report to the flight crew about the on-going situation.

**Power Push Unit Incidents Checklist**

Flight Crew	Ground Staff
<b>Aircraft unable to move alone—PPU removed</b>	
Asks for aircraft inspection.	<ul style="list-style-type: none"> <li>• Informs the flight crew that the rollers are open and the PPU is removed.</li> <li>• Leaves the interphone contact after consent from the flight crew.</li> </ul>
<b>Aircraft unable to move alone—PPU not removed</b>	
<i>If the engine on the opposite side of the PPU is running:</i> Shuts down the engine.	Informs the flight crew that the PPU is not removed.
<ul style="list-style-type: none"> <li>• Forbids the evacuation of passengers via the wing emergency exit on the PPU side.</li> <li>• Asks for aircraft inspection.</li> </ul>	<ul style="list-style-type: none"> <li>• Leaves the interphone contact after consent from the flight crew.</li> <li>• Fights the fire.</li> </ul>
<b>Aircraft able to move alone—PPU removed</b>	
Asks for aircraft inspection.	<ul style="list-style-type: none"> <li>• Informs the flight crew that the rollers are open and the PPU is removed.</li> <li>• Leaves the interphone contact after consent from the flight crew.</li> <li>• Guides the flight crew to move the aircraft forward.</li> </ul>
<b>Aircraft able to move alone—PPU not removed</b>	
<i>If the engine on the opposite side of the PPU is running:</i> Does not shut down the engine.	Informs the flight crew that the PPU is not removed.
	<ul style="list-style-type: none"> <li>• Leaves the interphone contact after consent from the flight crew.</li> <li>• Presses the most accessible stop button.</li> </ul>
<ul style="list-style-type: none"> <li>• Guided by the agent in charge of the departure operation, moves the aircraft forward with engine thrust overpowering the rollers jacks resistance.</li> <li>• Asks for aircraft inspection.</li> </ul>	Re-establishes the interphone contact and reports to the flight crew.

**3.13.8. Wingwalker**

- Wingwalker procedure shall apply for Corendon Airlines Flights.
- Wingwalker or other assist personnel must:
  - Be under the direction of the responsible ground crew at all times;
  - Use 2 marshalling wands, either day-wands or illuminated wands for low visibility operations;
  - Be positioned before and during movement of aircraft as follows:
    - Approximately 1 meter outboard of the wingtip;
    - In line with the rearmost main gear wheel.
  - Ensure the aircraft movement path is clear of any obstructions, other aircraft, vehicles etc.;
  - Provide “Safe to Proceed” clearance signals at all times to the person responsible for pushback by using a distinct “Pendulum” motion of the arm;
  - Must be in visual contact with person responsible for pushback/towing;
  - Continue to monitor the aircraft path until the aircraft is stopped at the departure point;
  - Position themselves in clear visibility of the flight crew on the terminal side, at a safe distance away from the aircraft (either at the 11 o'clock or 1 o'clock position); give the “AIRCRAFT HOLD” signal to the flight crew when the visual “Brakes Set” signal has been received from the person responsible for pushback. (crossed wands may be over head or in front of chest);
  - Remain in position until the responsible ground crew walks over to take over the marshalling clearance of the aircraft;
  - Return to terminal once marshalling duty has been transferred.

**Tractor Driver**

The pushback tractor driver will:

- Align the tractor or tractor and towbar combination with the center line of the aircraft before the aircraft movement;
- Completely raise the towbar wheels before the start of the aircraft movement (if used);
- Standby for clearance to push communication from flight crew or responsible ground crew;
- Select appropriate gear on tractor and slowly begin movement;
- Prior to the aircraft movement, make sure that the parking brakes are released and the anti-collision lights are switched on (depending on the local airport regulations);
- Start the pushback operation on a straight line;
- Keep the maneuvering speed to a minimum, and apply the vehicle brakes gently;
- Scan the apron during pushback, monitor clearances and wing walkers (if applicable) to ensure that aircraft is moving clear of all obstructions. Be prepared to stop;
- Ensure during pushback the steering turn limits are not exceeded and advise flight crew if any are exceeded. Damage to nose gear will occur. Refer to the operating airline's GOM for the specific limits and how they are marked on the aircraft;
- If responsible ground crew on interphone is walking on ramp, maintain visual contact and ensure a safe distance is maintained from the nose gear during entire pushback;

1. If the responsible ground crew is too close to the nose gear, the pushback must be stopped and a review of the required safety clearance conducted.

- Set brakes on the tractor once pushback is completed;
- Maintain the brakes on the pushback until the release signal is received from the flight crew or responsible ground crew on interphone;
- Wait for flight crew or responsible ground crew on interphone to give the "Aircraft Brakes Set" signal;
- Release the tractor brakes and put the gear selector in "Neutral" after aircraft brakes have been set, to release any pressure on the towbar;
- Position the tractor in the aircraft's path and be visible to the flight crew (if possible) after the towbar has been disconnected from the tractor;
- Remain in position visible to the flight crew until the headset operator has disconnected and is in view of the flight crew;
- Drive tractor back to terminal or appropriate parking position.

**Caution:** If the nose wheels are not in the centered position, they can turn quickly to their centered position when the bypass pin is removed. Personnel injury could result.

**3.13.9. Open Ramp Departure**

- (a) Complete all pre-departure checks.
- (b) Refer to departure communication section and follow required phases of dialogue.
- (c) Ensure all staff and equipment is clear of the aircraft behind the ERA.
- (d) Position for marshalling in an area behind the ERA while being in clear view of the flight crew on either side of the aircraft (depending on facility).

**3.13.10. Maneuvering during Adverse Weather Conditions**

During adverse weather conditions (fog, rain, etc.) visibility and traction will be affected.

The Tractor Driver must reduce and adapt vehicle speed as required by the present conditions.

**3.13.11. Icy Conditions**

When maneuvering the aircraft on slippery apron surfaces, extreme caution is required to avoid losing control of the tractor due to skidding. Many elements can contribute to the hazards involved such as strong winds, slippery road surfaces, pavement slopes etc.

Observe the following minimum precautions:

- (a) Avoid sudden turns, deceleration or acceleration.
- (b) Except when using an Air Start Unit, do not start aircraft engines unless:

1. the condition of the pavement is such that reasonable traction is ensured;
2. the aircraft parking brakes are set and the aircraft is disconnected from tow tractor/towbarless tow tractor.

### 3.13.12. Nose Gear Steering

The bypass pin must be:

labeled with the specific aircraft type(s) for which it can be used;  
identified with a "Remove Before Flight" streamer;  
checked regularly for proper technical condition.

- **Nose Gear Protection and Steering Angles**

In order to protect the nose gear from damage, visual turning limit markings indicate the aircraft's maximum nose gear steering angles. Refer to the operating airline's GOM for details.

**Danger:** In the event of exceeding the maximum nose gear steering angle, inform the maintenance department and flight crew, if applicable, and request a technical inspection. The aircraft must return to the parking stand in order to check whether the gear is damaged.

\*When using a towbarless tow tractor equipped with either an over steer warning or over steer protection device, verify the visual turning limit markings at all times to prevent exceeding the maximum nose gear steering angle.

\*When using a towbarless tractor on an aircraft, the "over steering" or "over torque" system of the tractor must be operative.

### 3.13.13. Anti-Collision Lights

On a standard departure, once all aircraft doors are closed, the flight crew requests pushback clearance from ATC. Once clearance is obtained the flight crew will switch on the aircraft's anti-collision lights.

**Caution:**

Anti-collision lights that are switched on are a visual indication to ground staff of imminent engine start-up or aircraft movement. Vehicle traffic must stop until the aircraft has departed from the area.

### 3.13.14. Engine Cross Bleed Start

Engine start using cross bleed can only be performed once the pushback has been completed, the aircraft brakes have been engaged, and the area around the aircraft is clear.

**Caution:** With engine(s) above idle thrust, blast and suction effects are greater.

### 3.13.15. Re-Establishing Communication after Departure

This procedure is to be used in case the ground staff or flight crew wishes to re-establish interphone communication after it has been disconnected.

- **Initiated from the Cockpit**

The flight crew sets the parking brake and re-establishes communication with ground staff via company channel or ATC. If visual communication with responsible ground agent is still established then visual signals may be used.

- **Initiated from the Ground**

If ground staff needs to re-establish communication with the aircraft after dispatch, do NOT approach the aircraft. If communication cannot be established using hand signals, make contact via company channel or through ATC.

When preparing to re-establish communication with aircraft, take the following precautions:

- (a) Make sure you have been seen by the flight crew and the intention to approach the aircraft to re-establish interphone communication is understood.
- (b) Approach the aircraft from the direction where visual contact with the flight crew is maintained as long as possible.
- (c) Only the person establishing the interphone communication shall approach the aircraft.
- (d) Stay outside the aircraft's engine danger area when approaching the aircraft.

(e) If possible, position pushback tractor in front of aircraft in clear view of flight crew to act as a safety barrier and prevent premature movement of the aircraft.

**Caution:** For safety reasons, the interphone communication system cannot be used when there is thunderstorm activity over the airport as there is a risk of electrical discharges between the aircraft and the interphone system. Under these conditions communication headsets cannot be worn.

### 3.13.16. Interphone Communication Failure

Aircraft pushback requires a communication interphone. In the event the interphone becomes unserviceable or communications is lost, the following procedure must be followed:

- (a) In case of a single person operation and if no other means of communication are available, stop the movement (depending on local situations and regulations) and immediately request assistance to continue the movement.
- (b) In case of multiple person operation then communication with the flight crew will be established using hand signals as described in this chapter. The tractor driver must be able to receive the visual signals as relayed from the flight crew. Once hand signal communication has been established the pushback can resume.
- (c) Notify ATC (if radio available) and continue the movement in co-operation with ATC, depending on local regulations.

- **Interphone Failure During Towing**

If during the tow the interphone fails, the tow must immediately be stopped and an alternate means of communication established before continuing. If this is not possible, assistance must be requested.

## 3.14. AIRCRAFT TOWING

### Ground Crew Responsibility:

- Responsible ground crew for the towing will:
  - i. Make sure that Maximum aircraft nose gear turn limits are not exceeded.
  - ii. Make sure that there is a safe connection, operation and disconnection of the towing.
  - iii. Ensure that the tow bar/shear pin/towbarless tractor is suitable for the specific aircraft type.
  - iv. Standardized communication is used between the ground crew and the flight crew

### 3.14.1. Aircraft Towing Requirements

The following requirements must be met to perform an aircraft tow:

- (a) Ensure hydraulic system pressure for aircraft braking and/or the brake accumulator is within required pressure range.
- (b) Ensure any required electrical systems for towing are energized.
- (c) Ensure all gear safety pins/sleeves are installed, and after tow, ensure all pins are removed and stowed. Refer to Corendon Airlines GOM 3.13.12 procedures regarding gear lock pin responsibilities and requirements.
- (d) Make sure a qualified brake operator is in the cockpit.
- (e) Establish communication with the brake operator by means of the interphone system.
- (f) Make sure wheel chocks are positioned at the end of the maneuver, prior to disconnecting the towbarless tow tractor or towbar.

**Caution:** Inform the brake operator/flight crew and/or contact the maintenance department for technical inspection if you: observe any type of excessive fluid leakage; notice any signs of unmarked aircraft damage; observe any fault, failure, malfunction or defect which you believe may affect the safe operation of the aircraft for the intended flight.

### 3.14.2. Towing Maneuvering

The towing maneuvering procedure is similar for all aircraft types. The following minimum safety precautions and procedures must be followed prior to and during aircraft towing operations:

- (a) Align the tractor or tractor and towbar combination with the center line of the aircraft before the aircraft movement.
- (b) Completely raise the towbar wheels before the start of the aircraft movement (if used).
- (c) Prior to the aircraft movement, make sure that the parking brakes are released and the anti-collision lights are switched on (depending on local airport regulations).
- (d) Wait for the authorization of the flight crew or brake operator before moving the aircraft.
- (e) Start the pushback operation on a straight line.
- (f) Keep the maneuvering speed to a minimum, and apply the vehicle brakes gently.
- (g) Do not exceed the towing speed limit as regulated by the towing equipment, aircraft and/or airport.
- (h) Use relevant apron lines as guidance during maneuvering to ensure safe obstacle clearance.
- (i) Keep a minimum safety distance between vehicles sufficient in which to stop.
- (j) Stop 50 m/55 yd. before a taxiway intersection, if a stop is required.
- (k) Avoid sharp turns, which results in excessive tire scrubbing.
- (l) Make all stops smoothly.
- (m) When arriving at the allocated position, move the aircraft in a straight line for a few meters to ensure that the nose wheels are in the straight ahead position. This relieves any torsional stress applied to landing gear components and tires.
- (n) Apply the tractor parking brake after a complete stop.

**Note:** Some of these precautions may not be applicable to towbarless vehicles.

### 3.14.3. Towing Preparation

The following checklist is to be used in preparation for an aircraft tow. Refer to IGOM 4.9.3.2

### 3.14.4. Towing Completion

The following checklist is to be used at the end of an aircraft tow. Refer to IGOM 4.9.6

### 3.14.5. Incidents during Towing

For detailed information, refer to IGOM 4.9.5

### 3.14.6. Towing Limits

- (a) Fuel and other loads can affect an aircraft's balance. To avoid "tail tipping" during towing, ensure that the actual centre of gravity of the aircraft is forward of the critical centre of gravity. If you are unable to determine this, then you must request assistance from a qualified weight and balance agent of the operating airline.
- (b) Refer to the operating carriers GOM for respective aircraft type specific instructions for further details.

### 3.14.7 Long Term Parking for Aircraft

#### ➤ Introduction

Successful execution of the long-term parking operation, as well as the recovery and reintroduction of the aircraft back into service after long-term parking, requires close coordination and cooperation between all of the relevant airside and aviation stakeholders, including (but not limited to) the aircraft operator, airport authority, ground handling provider, and maintenance provider.

In anticipation of the possible long-term parking of multiple aircraft, ground service providers shall proactively engage with the relevant stakeholders to develop a long-term parking plan. This plan shall be regularly reviewed (minimum once per year) to ensure the plan is still valid. The plan will require ad hoc review in response to changes to the airside environment, such as changes to operators, aircraft types and numbers, airport layout, ground handling service providers and manufacturers' Aircraft Maintenance Manual (AMM).

Depending on each airport's emergency plan, the airport may require the aircraft to proceed to a designated bay, possibly a remote bay, according to its plans and requirements.

The long-term parking plan shall ensure:

- (a) Spacing between adjacent aircraft.
- (b) When not parked at a bay (e.g., taxiway), aircraft are parked facing into the prevailing wind.
- (c) Anchor points are available for high-wind conditions.
- (d) Processes to monitor and adjust for severe weather conditions

**Caution:** In regions with hot climates, it is preferable to park aircraft on hard surfaces such as concrete or high module asphaltic material rather than on flexible surfaces such as bituminous asphalt. This will avoid indenting those areas during long parking periods.

➤ **Aircraft Movement**

Based on the airport parking plan, once resumption of operations begins it is important to ensure there is a well-coordinated aircraft movement plan to ensure there is no damage to the aircraft.

**Note 1:** Ensure all procedures during aircraft ground movement are adhered to as documented in IGOM 4.6 to 4.9

**Note 2:** Ensure during any non-normal operations, a robust safety risk assessment is performed, and implementation of the mitigation plan is followed.

**Note 3:** Ensure timely consultation with the airport operator regarding the aircraft movement.

**Note 4:** If any surface damage is observed, liaise with the airport management team as per the airport's directives.

**Caution:** After long-term parking, anticipate extra pull or push force required for aircraft wheels to exit any indentations in the pavement and/or to overcome the aircraft tires being out of round. This is to avoid shear pin breakage and/or sudden movement in direction of travel. Refer to the pushback and pull forward procedure in IGOM 4.6.7.4

### 3.15. AIRCRAFT DE/ANTI ICING

Corendon Airlines requires the application of and compliance with the Federal Aviation Administration (FAA) Recommendations for De-icing / anti-icing aircrafts on the Ground, current edition, except as otherwise specified in this instruction. This instruction is limited to ground procedures.

This program;

- (i) adherence to Clean Aircraft Concept;
- (ii) is applicable to external service providers that perform de-/anti-icing functions for CAI;
- (iii) includes locations where CAI perform operations;
- (iv) defines areas of responsibility and responsibilities within the Program;
- (v) specifies technical and operational requirements;
- (vi) specifies training and qualification requirements;

As a policy, CAI follows FAA Recommendations as priority for each case such as fluid application, Fluid residue management, Post De-Icing/Anti-Icing Check, aircraft limitations, clean aircraft concept, etc...

#### 3.15.1. Procedures

To ensure 'Clean Aircraft Operation' a pre-flight contamination check must be performed in case of Freezing Conditions and at any other time contamination on the aircraft can be expected.

#### Contamination Check

It is the Pilot In Command's responsibility to determine the need for a de-icing / anti-icing treatment.

#### Pre-step

A pre-step process prior to the de-icing process, in order to remove large amounts of frozen contamination (e.g. snow, slush or ice), may be considered to reduce the quantity of glycol-based de-icing fluid that is needed. This process may be performed with various means (e.g. forced air, heat, heated water, heated fluids (see also; Chapter 3.15.5 - No de-icing / anti-icing fluid available). If the pre-step procedure is used, make sure that the subsequent de-icing process removes all frozen contamination that may have formed on surfaces and or in cavities due to the pre-step process.

#### 3.15.2. Precautions for de-icing / anti-icing

Aircraft shall be treated symmetrically (left and right the same treatment) even when only one side of the aircraft is contaminated. If the wing and/or the horizontal stabilizer/elevator is to be treated, the treatment

shall always cover the entire wing and/or the entire horizontal stabilizer/elevator on both sides of the aircraft. Otherwise aerodynamic problems could result.

When two-step de-icing / anti-icing is performed and the fuselage is de-iced there is normally no reason to apply the second step (anti-ice) on the fuselage as the interior heating will prevent re-freezing. In this way cabin windows will stay free from anti-icing fluid.

Under no circumstances shall an additional coating of anti-icing fluid be applied on top of an existing layer of anti-icing fluid, as this may affect the flow off characteristics of the fluid during take-off. If an additional treatment is required before flight, a complete de-icing/anti-icing shall be performed. Ensure that any residues from previous treatment are flushed off.

**Note: If de-icing/anti-icing procedures are interrupted or unsuccessful a new de-icing/anti-icing treatment must be performed. Before commencing the new treatment ensure that any fluid remains of the previous treatment is removed.**

### 3.15.3. Fluid application

Fluid mixture ratios shall be established according the fluid application guidelines as described in FAA recommendations.

### Fluid residue management

The use of hot water or heated mix of Type I fluid/water for the first step of a two-step de-icing/anti-icing process may minimize the formation of residues. Residue could also occur when surfaces have been treated but the aircraft has not subsequently been flown.

### 3.15.4. Post De-Icing/Anti-Icing Check

In case no trained and qualified person is available to perform the post de-icing/anti-icing check, the flight crew is authorized to perform this check.

### 3.15.5. No De-Icing / Anti-Icing Fluid Available

When no de-icing fluids are available, the following methods may be used to de-ice the aircraft.

**WARNING: These methods do not provide anti-icing protection.**

\***Mechanical** Dry snow, on a cold-soaked aircraft may be removed by mechanical means with brooms or a suitable substitute.

\***Melting off in hangar** This includes a risk of re-freezing in sub-zero outside temperatures.

\***Application of heated air**

Heated air from e.g. specially equipped air starting units, can be used for removal of ice and snow from components such as flight control hinges, aircraft doors, fuel sumps, drains, etc. Components should be treated till they are completely dry. The heated air temperature must not exceed 80° C to prevent local overheating. A large volume of warm air is much safer than a small volume of hot air. This normally requires a special venturi nozzle on the air starting unit to permit diluting with colder air.

**Note: Always be alert on the possibility of re-freezing in critical areas.**

### 3.15.6. De-icing Fluids and holdover time tables

Corendon Airlines only uses generic hold over time tables as depicted in FAA recommendations, no brand name specific hold over time tables shall be used. For more details, please visit:

[https://www.faa.gov/other\\_visit/aviation\\_industry/airline\\_operators/airline\\_safety/deicing/](https://www.faa.gov/other_visit/aviation_industry/airline_operators/airline_safety/deicing/)

### 3.15.7. Responsibilities regarding de-icing / anti-icing

#### 3.15.7.1 Responsibility of Commander

The commander shall not commence take-off unless the aircraft external surfaces are clear of any contamination which might adversely affect the performance and / or controllability of the aircraft, or if prior to departure it is determined that a take-off cannot be made within the holdover time. The final decision on whether a de-icing / anti-icing treatment is given shall be made by the commander.

The decision shall be based on checks of aircraft critical surfaces and evaluation of overall operating and weather conditions. After receiving the 'anti-icing code', the Commander is responsible for ensuring that the aircraft critical surfaces remain free of frost, ice, snow or slush until take-off.

### **3.15.7.2 Responsibility of De-icing/Anti-icing Company**

A Deicing Service Provider shall have aircraft deicing/anti-icing procedures, including a quality control program. These procedures, which ensure compliance with the relevant regulations, shall cover all aspects of the aircraft ground deicing/anti-icing process including (but not limited to) instructions, tasks, responsibilities, authorizations and infra-structure for the deicing/anti-icing process as follows:

- Use of suitable deicing/anti-icing treatment method according this Aerospace Standard
- Remote deicing/anti-icing instructions (when applicable)
- Sufficient number of trained and qualified deicing/anti-icing personnel.
- Qualified Staff to co-ordinate and supervise the deicing/anti-icing treatments
- Use of suitable deicing/anti-icing equipment meeting specification SAE ARP1971.
- Post-deicing/anti-icing check (when applicable)
- Protocol for communications with cockpit crew for both gate and remote locations (when applicable)
- Reporting the anti-icing code to the cockpit crew with brand name of the product.
- Documentation of all deicing/anti-icing treatments.
- Personnel safety arrangements.
- Provisions for tools and clothing for deicing/anti-icing personnel.
- Environmental arrangements.
- A quality control program.

### **Communication between Ground Staff and Flight Crew**

Ground handling personnel shall communicate with the flight crew to assure:

- The aircraft is properly configured prior to beginning the de-/anti-icing process;
- The flight crew receives all necessary information relevant to fluid(s) applied to the aircraft surfaces;
- The flight crew receives confirmation of a clean aircraft;
- The flight crew receives an "all clear" signal at the completion of the de-/anti-icing process and prior to aircraft movement.

Communication is necessary between ground handling personnel and the flight crew prior to and after completion of the de-/anti-icing process.

### **3.15.8. Company Inspecting**

CAI ensures the availability and use of adequate facilities and equipment for aircraft de-/anti-icing operations at applicable locations by monitoring such as postal audits, product audits, system audits, etc. in accordance with FAA recommendations/Corendon Airlines standards.

The Anti-Icing code is the confirmation that the aircraft critical surfaces are free of frost, ice, snow or slush at the completion of the de-icing/anti-icing treatment. In case no Company Inspecting is available, the flight crew may perform this task.

### **3.15.9. Approved Fluids**

CAI ensures fluids used in de-icing and anti-icing operations are stored, handled and applied in accordance with criteria established by FAA recommendations/Corendon Airlines, fluid manufacturer, Boeing; and manufactured / used in accordance with ISO/SAE specifications which are below:

- Type I fluids meeting ISO 11075 / SAE AMS 1424 standards
- Type II fluids meeting ISO 11078 / SAE AMS 1428 standards
- Type IV fluids meeting ISO 11078 / SAE AMS 1428 standards

**Cautions:**

- **Type III fluid may never be used for the de-icing / anti-icing of Corendon Airlines aircraft.**
- **Additional guidance may be found in ICAO Doc 9640-AN/940, Manual of Aircraft Ground De-icing/Anti-icing Operations,**

**3.15.10 Staff Training and Qualification**

Training programs shall follow the guidelines and recommendations published in AS6286. The training should be performed as close as possible prior to the beginning of the deicing season.

- **Theoretical training** shall be completed before start of practical training. A recurrent theoretical instruction for deicing/anti-icing must be performed every year before start of the De-Icing season. If for any reason a person has not completed a recurrent training or has not been working actively any deicing/anti-icing processes for more than two full local De-icing season, the qualification expires and a complete basic training for re-qualification shall be performed. Recommended elements for training can be found in the last release of AS6286 Training and Qualification Program for Deicing/Anti-Icing Processes.
- **Practical Training** - Recommended elements for training can be found in the last release of AS6286 Training and Qualification Program for Deicing/Anti-Icing Processes.
- **Examination and Records** - An examination and assessment program should be established covering the training topics as listed in AS6286. The names of training participants and their training results for proof of qualification should be recorded. The minimum passing mark for the theoretical examination is 75%. Only personnel having passed the examination successfully are qualified. The theoretical examination must be in accordance with EU Part-66 or any equivalent requirements. Before granting final qualification to personnel who perform Deicing/Anti-Icing operations (driving and/or spraying), a practical assessment shall be performed in actual operational conditions involving an actual aircraft (as applicable) before initial qualification to a qualified trainer or supervisor. Further evaluations may be performed as applicable for the local demands and/or company requirements. Two latest training records shall be kept as minimum in accordance with AIR-OPS. A recurrent theoretical instruction for Deicing/Anti-Icing must be performed every year before start of the Deicing season. As practical training is regarded separately and not subject to recurrent training as long as a person continues to be active in the field of De-Icing / Anti-Icing, it could happen that after 2 years there is no more evidence that a practical training ever took place.
- **Training Subjects**  
Training subjects shall include but are not limited to the following (when applicable):
  - Effects of frost, snow, slush, ice, and fluids on aircraft performance.
  - Common standard, regulation and recommendation including local rule and restriction
  - Hazard of snow, ice and frost
  - Deicing/anti-icing codes, communication and coordination
  - Basic characteristics of aircraft deicing/anti-icing fluids, including causes and consequences of fluid degradation, fluid remaining on surfaces, and dried and/or rehydrated residues. Types, purpose, characteristics, and effectiveness of deicing and anti-icing fluids as applicable. Deicing/anti-icing fluids handling/performance implications.
  - General techniques for removing deposits of frost, snow, slush, or ice from aircraft surfaces and for anti-icing.
  - Deicing/anti-icing procedures in general and specific measures to be performed on different aircraft types.
  - Types of checks required.
  - Deicing/anti-icing equipment and facilities operating procedures including actual operation.
  - Safety precautions.
  - Emergency procedures.
  - Fluid application and limitations of holdover time tables

- Deicing/anti-icing codes and communication procedures.
- Special provisions and procedures for contract deicing/anti-icing (if applicable).
- Environmental considerations, e.g., where to deice, spill reporting, hazardous waste control.
- New procedures and development, lessons learned from previous winters.
- Conditions which can lead to the formation of ice on the aircraft.
- The use of holdover times (flight, dispatcher, and ground).
- Responsibilities (flight, dispatcher, ground).

### 3.16. AIRCRAFT CLEANING

#### 3.16.1 General

Clean and prepare the following five areas as per Corendon Airlines standards

- Seats
- Cabins
- Flight Deck
- Galleys
- Toilets

##### 3.16.1.1 Seats

- Rough out all waste, including waste disposal (sick) bags, seat pockets and ashtrays. Ashtrays to be emptied and brushed out
- All seat pockets stowed in uniform pattern with Safety On Board cards visible at front
- Headrest covers clean, increased & of correct style
- Arm rests & ashtray covers clean and unmarked
- Tables completely clean, including table lips, no cup rings, no finger marks on the table back, liquid runs or food particles
- All pockets correctly stocked and neatly stowed in uniform pattern, no debris remaining
- Seat belts straightened and crossed.
- Remove and replace headrest covers, pillow covers and blankets. Ensure all seats are dressed uniformly.

##### 3.16.1.2 Cabin

- Floors vacuumed leaving no loose dirt or debris. Remove marks and chewing gum etc. from the carpets. Spot clean carpet where necessary
- Clean overhead lockers.
- Wipe video screens removing all marks and smears
- Wardrobes cleared out and free of debris
- Passenger door interior panels clean of any finger marks, smears or any obvious isolated marks
- No debris in magazine racks and no obvious marks on outsides. Magazines neat and tidy
- Armrests re-positioned as required
- Dispose litter
- Wipe tray tables
- Clean floors carpets and surrounds by using of vacuum cleaner

##### 3.16.1.3 Toilets

- Do not re-use the mops and napkins used for toilet cleaning when cleaning the galley
- All waste removed, bins disinfected if requested
- Mirrors, basin & fittings clean with no smears
- Walls and ceilings clear of any obvious isolated marks
- All amenities fully stocked with approved sizes/patterns

- Floors washed and clean with no debris or ingrained dirt remaining
- Toilet seat lid completely clean.
- Toilet surrounds clean, no fluid marks or stains
  
- Check/renew deodorant if fitted

### 3.16.1.4 Galleys

- All waste cleared, bin liners replenished, bins disinfected if requested
- Work tops, framework, ovens clean with no food residues remaining
- Remove any rubbish from sinks and work tops, clean and polish dry
- Clean all stowage doors, panels and frameworks.
- Clean and vacuum stowage areas

### 3.16.1.5 Flight Deck

- Do not enter the flight deck unless the flight crew or airline authorized technician is present to avoid operating any switches during cleaning
- Empty waste bins and ashtrays
- Floors clean and free of any loose debris

### 3.16.2 Cleaning Equipment

All equipment and materials used to clean aircraft shall be approved in accordance with national/international standards

- **Vacuum Cleaner:** operating on aircraft power for carpets, air vents, seat arm stowage's and seat rails and behind stowage's. Manual carpet cleaners are not an adequate substitute but may be necessary when time is limited or large numbers of passengers remain on board.  
**Caution:** Do not unplug by pulling the cord from the socket
- **Hand Brushes:** for use on areas inaccessible to vacuum cleaners
- **Chewing Gum Remover:** to remove chewing gum
- **Mops and Brushes:** for floor and hard surface washing. Must be clearly identified or color coded for toilet cleaning and general cleaning
- **Towel/White Cloth:** for general purpose cleaning and polishing. Must be clearly identified or color coded for toilet cleaning and general cleaning
- **Absorbent Wipes:** for mopping up spillages
- **Hand Sprayers:** for dispensing detergent mix
- **Runners:** for floor protection
- **Soft Rolls/Wipes:** for wiping off spillages

### 3.16.3 Health and Safety General Instructions

- Wear the required personal protective equipment
- Exercise caution while checking the contents inside the seat covers to prevent cuts and injuries by any sharp items placed there
- Ensure suitable disposal containers are available and used for the removal of soiled articles, waste and sharps
- Disposal of waste must be done in accordance with local airport authority regulations
- Use the correct and approved cleaning materials
- Be familiar with the Material Safety Data Sheets (MSDS) to understand the hazards of the chemicals used in cleaning
- Take care while using passenger boarding bridge, stairs.

**3.16.4 Lost/Found/Damage/Suspicious Items**

- Do not check/open any items found as the nature of the contents inside is unknown and has the potential of being harmful/dangerous
- Any lost property found must be handed in.
- Any seat or cabin interior/area found damaged must be reported as appropriate
- Any suspicious item found must be immediately reported

**3.16.5 Garbage Disposal**

- All aircraft garbage must be transported to the designated disposal area
- Do not obstruct jetties or steps with garbage bags
- Do not throw garbage bags onto the ramp from the aircraft or from the GSE.

**3.17 Protection of Aircraft**

Our company protects our parked aircraft from unauthorized interference. Regardless of where an aircraft is parked at an airport, it shall be protected against unauthorized access by:

- a) Ensuring that persons seeking to gain unauthorized access are challenged promptly; or
- b) Having its external doors closed. Where the aircraft is in a critical part, external doors that are not accessible from the ground shall be considered closed if access aids have been removed and placed sufficiently far from the aircraft as to reasonably prevent access; or
- c) Having electronic means which will immediately detect unauthorized access.
- d) Having an electronic airport identification card access system at all doors leading directly to the passenger boarding bridge, adjacent to an open aircraft door, which only allows access for persons who are trained in accordance with point 11.2.3.7 of the Annex of Regulation (EU) No. 2015/1998. Such persons must ensure that unauthorized access is prevented, during their use of the door.

Above listed points do not apply to an aircraft parked in a hangar that is locked or otherwise protected from unauthorized access.

Corendon Airlines take prevent measures for access control measures and security screening measures as mandated by the State are in place to prevent the introduction of unauthorized weapons, explosives or other dangerous devices or items on board an aircraft by persons other than passengers.

Typically, access control and security screening measures will apply to personnel of Corendon Airlines and its service providers.

The baseline for such measures typically would be that a person:

- Holds a valid authorization to enter a security-restricted area (based on, as a minimum, a background check, operational needs and completion of security awareness training);
- Is subjected to screening (combination of equipment and procedures aimed at identifying and/or detecting all potentially dangerous items, substances, and devices that could be used to commit an attack).

As a reference, ICAO Annex 17 requires states to establish measures to ensure applicable personnel are screened prior to entry airport security restricted area, including use of appropriate screening methods capable of detecting explosives either continuously or in an unpredictable manner. An effective method to deter or detect illegal access to aircraft is the implementation of frequent but irregularly timed patrols by security personnel. This is particularly important when operations are at their lowest levels and aprons and hangar areas are least frequented. Such patrols are normally conducted by airport personnel.

Additional measures to prevent unauthorized access to passenger aircraft may include:

- Parking aircraft in a well-lit area; adding security lighting, if necessary;

- When possible, parking aircraft in an area visually observable and/or covered by CCTV;
- Parking aircraft away from fences or buildings that might provide easier access;
- For aircraft parked overnight, depending on the assessed risk at the location, applying a tamper-evident seal to all exterior doors accessible without aids or verifying the identity of all persons who access the aircraft to ensure a legitimate reason for accessing the aircraft;
- For aircraft parked remotely from a loading bridge:
  - Closing all exterior doors and exterior hatches of the aircraft;
  - Removing all stairs;
  - Ensuring no portable stairs, lift devices or passenger transfer vehicles are in the immediate vicinity of the aircraft.
- For aircraft parked with access to a loading bridge:
  - Closing all exterior hatches of the aircraft;
  - Closing all exterior doors of the aircraft not served by a bridge;
  - Locking the door between the terminal and the bridge;
  - Ensuring no portable stairs, lift devices or passenger transfer vehicles are in the immediate vicinity of the aircraft;
  - Locking or keeping under constant surveillance doors that provide access to the bridge from the apron or retracting the bridgehead from the aircraft and deactivating the bridgehead positioning controls.

When a higher level of threat is known to exist, the following additional precautions may be recommended:

- Providing additional security lighting stands;
- Ensuring frequent irregularly timed security patrols on foot or by vehicle;
- Providing monitoring via closed circuit television (CCTV);
- Applying tamper-evident seals to doors, operable windows, inspection and service panels;
- Putting covers on access points such as engine intakes;
- Where external doors are closed and the aircraft is in a part other than a critical part, each external door shall also:
  - (a) have access aids removed; or
  - (b) be sealed; or
  - (c) be locked; or
  - (d) be monitored.
- Point (a) shall not apply for a door that is accessible from the ground.
- Where access aids are removed for doors that are not accessible from the ground, they shall be placed sufficiently far from the aircraft as to reasonably prevent access.
- Where external doors are locked, only persons with an operational need shall be able to unlock these doors.
- Where external doors are monitored, the monitoring shall ensure that unauthorized access to the aircraft is immediately detected.
- The protection of aircraft with closed external doors in a part other than a critical part shall also be subject to the additional provisions laid down in a separate Commission Decision.

In case there is an intrusion, the security supervisor and air carrier representative shall be notified immediately. If there is evidence of intrusion into an aircraft cabin or hold, a detailed search shall be carried out. The aircraft search will be carried out according to air carrier procedures and local circumstances.

### 3.17.1 Aircraft Sealing

Corendon Airlines may seal the aircraft during the overnight or layover. Sealing implementation perform stated below circumstances;

- a. Required by Airport Security Authorities,
- b. VIP flights,
- c. Received threat or suspicion condition,
- d. Captain decision (insufficient security of the airport),
- e. Published MEMO or instruction from Senior Aviation Security Manager

Sealing process is performed by crew or aircraft technicians.

#### When sealing external doors we ensure the following:

- a) Security seals are tamper-evident, individually numbered and controlled.
- b) The seal numbers are recorded and the records are kept at the station by the air carrier for 24 hours or the duration of the flight, whichever is longer.

Prior to accessing the aircraft, the seals and seal numbers are inspected for signs of tampering. If tampering is detected or suspected, the relevant parts of the aircraft will be subjected to an aircraft security search before boarding or loading. Where external doors are sealed and the aircraft is then moved into a critical part these requirements also apply in the critical part.

In addition to the Aircraft Excess Doors which are mentioned above, Corendon Airlines apply sealing procedure for the following exterior service panels and hatches.

- Forward Equipment Compartment Access Door;
- Electronic Equipment Access Door;
- Air Conditioning Access Doors(2);
- Hydraulic Equipment Access Door.

Those doors shall be sealed by authorized maintenance personnel or flight crews comply with (EU) Regulation No: 774/2010 which requires through examination of the areas when they are accessible without the use of tools, keys, stairs or other aids, and without breaking seals.

**4. LOAD CONTROL AND COMMUNICATION SYSTEM****4.1 WEIGHT AND BALANCE DOCUMENTATION****4.1.1. Preparation of a Loading Instruction**

a. A loading instruction has to be prepared for every incoming and/or outgoing flight and the following information has to be mentioned in the loading instruction:

- The applicable weight & balance system shall be used according to latest revision of AHM560.
- A trained load control agent;
- The load control agent must collect all applicable weight & balance and commodity data including:
  - Passenger Load Information and distribution;
  - Hold baggage and if applicable individual or cumulative weights;
  - Gate delivery items, including individual or cumulative weights;
  - Other non-normal items that must be considered in the load control process;
  - Dangerous goods and other special load information;
  - Cargo and mail;
  - Ballast;
  - Aircraft technical kit in cargo hold.

The above special load information should be identified/informed to the load controller by Corendon Ground Operation Department.

- Ensure the final information provided to the flight crew on the final load sheet is in agreement with the actual load on the aircraft.

b. The loading instruction/report and the off-loading instruction/report must be completed and signed by the persons responsible for loading and or off-loading respectively. The forms must contain a certificate, signed by the person responsible for the loading respectively off-loading of the flight.

c. Loading and load sheet activities are not complete and the aircraft not cleared to leave until the load sheet and the loading instruction/report are in agreement. Deviations must be checked against the weight, balance and loading limits. Any necessary corrections made to the recorded weight and balance conditions before the aircraft departure must be in accordance with pilot in command.

d. The maximum weights for loading compartments/positions of the respective aircraft must be observed.

e. In order to save as much fuel as possible, ideal trim values should be used in accordance with AHM560

f. The person supervising the loading of the aircraft must confirm by signature that the load and its distribution is in accordance with the loading instruction. The signed copy has to be added to the trip file.

**4.1.2. Load & Trim Sheet Preparation**

Load and Trim sheets prepared manually or digitally for Corendon Airlines flights.

The Corendon Airlines Electronic Load & Trim Program may be used at present stations and/ or the flight crew.

**Use of the Corendon Digital Load & Trim Program:**

a. The Corendon Airlines Electronic Load & Trim Program can be used only at present stations after authorization by Corendon Airlines Ground Operations Department.

b. The Handling Provider must ensure that:

-The updated version is in use only.

-All staff assigned to prepare Load & Trim Sheet via this electronic program shall also remain familiar to the manual Load & Trim Sheet.

**Distribution:** <https://handling.corendonairlines.com>

Note: The Handling Agent shall ensure that one copy of the approved document will be taken by the pilot while the other one retains in the records of the station for minimum 3 (three) months and is destroyed thereafter.

**Use of Departure Control System (DCS) Load Sheet outputs:** Agencies who have their own DCS system may prepare load sheets digitally.

-Aircraft data information should be updated as per the latest version of AHM560.

-In case only the aircraft data is changed, the test load sheet is asked from the DCS provider and approved by Corendon Airlines Ground Operation Supervisor.

**Use of Manuel Load Sheet:**

- a. Manual Load and Trim Sheet must be used when it is not possible to prepare Digital Load and Trim Sheet.
- b. Data and forms including aircraft registration, DOW/DOI values, load and trim forms, maximum weights limitations etc. are made available onboard by Flight Operations Engineers.
- c. Catering groups for the respective flights/aircraft are to be found on the CORENDON AIRLINES Catering group. The group classifications and corresponding DOW/DOI are depending on the number of meals carried on board the aircraft and not on the version of the aircraft. Do not forget to include EIC (CSU/catering equipment) in your calculations.  
DOW includes Basic Empty Weight, Crew Weight and Pantry Weight (equipment, food, beverages).  
DOW/DOI tables are revised:
  - after each aircraft weighing
  - if cumulative changes to the dry operating mass exceed  $\pm 0,5 \%$  of the maximum landing mass or the cumulative change in CG position exceeds  $0,5 \%$  of the mean aerodynamic chord.
- d. MTOW must be taken from the Trip Info.
- e. Special Load Remarks e.g. DGR's have to be mentioned on the load sheet (refer to abbreviations used in regard with load and trim sheet)
- f. It must be confirmed by signature that the load and its distribution shown on the load sheet is in accordance with the loading instruction.
- g. The weight and balance documents (load sheet) must be handed over to the cockpit crew at least 10 minutes prior to departure. In cases of Last Minute Changes (LMC) the Load Sheet can be updated according to LMC-procedure

**4.1.3. Applicable Weights for Passengers, Baggage and Crew**

**Passenger Weights**

Flights	Passenger	Weight	Note
All Flights except holiday charters	MALE / FEMALE	Male: 88 KG Female: 70 KG	Use these values for all flights unless otherwise stated by the commander or ground operations department before flight.
All Flights except holiday charters	ADULT	84 KG	Do not use these values unless otherwise stated by the commander or ground operations department before flight.
Holiday charters	ADULT	76 KG	Do not use these values unless otherwise stated by the commander or ground operations department before flight.
ALL FLIGHTS	CHILDREN	35 kg	Always use this value
ALL FLIGHTS	INFANT	10 kg	Always use this value
*Non-Standard Groups	-	-	-

\*Any flight identified as exclusively carrying passengers whose weights are expected to fall outside the standard passenger weight, e.g. military personnel, athletic teams, the passenger weight should be determined after consultation between Ground Operation Department and Engineering Department.  
Cabin baggage weight is included in the above mentioned passenger weights.

Holiday charter means a charter flight that is part of a holiday travel package. On such flights the entire passenger capacity is hired by one or more charterer(s) for the carriage of passengers who are travelling, all or in part by air, on a round- or circle-trip basis for holiday purposes.

The holiday charter mass values apply provided that not more than 5 % of passenger seats installed in the aircraft are used for the non-revenue carriage of certain categories of passengers. Categories of passengers such as company personnel, tour operators' staff, representatives of the press, authority officials etc. can be included within the 5% without negating the use of holiday charter mass values. (AMC1 CAT.POL.MAB.100 (e))

**Passenger Baggage Weight**

**a. If weighing is possible**

Weight per piece	Actual
Weight per passenger	Actual

**b. If weighing is not possible**

	Weight per piece
Flights within European Region as defined in SHT OPS1 App 24	13 Kg.
One-Off Flights	11 Kg.
Intercontinental other than those within European Region	15 kg.
All other	13 kg

**Crew and Crew Baggage Weights**

	Standard
Cockpit Crew	85 Kg
Cabin Attendant	75 Kg

Crew hand baggage is included in the above crew weights

Actual weights shall be used and recorded into the L&T sheet separately for crew baggage weight (other than hand baggage).

**4.1.4. Passenger Distribution**

The number of passengers (without infants) in the respective cabin section according to the actual passenger seating have to be filled in the load and trim sheet. For flights without seat allocation a standard passenger distribution can be used according to the tables in respective aircraft chapters.

**4.1.4.1. Seating Policy/Procedures**

The mass and balance sheet is prepared assuming a particular passenger seating distribution. If a seat allocation system is used in connection with the preparation of the mass and balance sheet, potential errors in the CG position will be covered/compensated by the operational CG envelope - providing the passengers are seated where they are supposed to. "Free seating" however might require a repositioning of passengers in the cabin. The commander shall instruct the cabin crew to reseat passengers so as to create an actual seating distribution in compliance with the assumed distribution on the mass and balance sheet.

**4.1.5. Example of a Manual Corendon Airlines Load Trim Sheet**

For Load and Trim Sheet samples please contact to ground operations. Contacts refer to GOM section 1.1.3.

**4.2 USE OF LOAD AND TRIM SHEET**

- a. The load and Trim Sheet shall be completed in triplicate for each departure.
- b. Corendon Airlines make use of computer based software or printed hard copy load and trim sheet for load and trim calculations which are both approved by the Turkish DGCA.
- c. The Load and Trim Sheet indicates the influence at least of the load distribution on the airplane CG. It serves the purpose of ensuring safe balance conditions as well as determining the CG position at takeoff.
- d. The basis for determination of the CG. Is the "Dry Operating Index" (DOI). The different scales for compartments and passengers will give influences of load distribution on the index movement.
- e. According to the aircraft and seating version the applicable LT must be completed in duplicate for each departure in conjunction with the Load Sheet and will be disturbed as follows:

**Original** : on board the aircraft in the "Weight Control Folder"

**Copy** : to the station trip file.

- f. The L&T must be filled with the followings:

- i. Station Teletype address the preparing station
- ii. Flight No/Date/Time in UTC (CAI flight number/ date)
- iii. Version/Crew Aircraft version and number of operating crew
- iv. Operations group law to the respective loading list
- v. Cockpit/crew number of persons in the cockpit
- vi. Dry Operating Index
- vii. Weight column of forward compartment 1 and Compartment 4
- viii. Passenger compartments OA thru OC, number of passenger in the respective cabin section (actual passenger distribution)
- ix. Scale for the indication of the DOI as the starting point for the direction by arrows.
- x. Vertical Line Draw from the last trim scale through the MAC diagram indicates the Loaded Index at Zero Fuel Weight (ZFW) Draw horizontal line corresponding to Zero Fuel Weight and Take Off Weight (TOW) Use fuel pattern as described in AOM
- xi. Scale for fuel index correction acc. fuel quantity (TOF)
  - The loaded index at Take Off Weight (LITOW) and
  - The MAC at TOW = point of intersection with the horizontal line marking the TOW
- xii. Determined MAC at TOW: results from the point of intersection of the horizontal line marking the TOW and the vertical line for performed fuel index correction.
- xiii. The person preparing the mass and balance documentation must be named on the document. The person supervising the loading of the aircraft must confirm by signature that the load and its distribution is in accordance with the mass and balance documentation. This document must be acceptable to the commander. At destinations where Digital Load Sheet software is used, use of digital signatures traceable to the person who prepared the mass and balance documentation are acceptable.

**4.2.1. List of Corendon Airlines Aircraft and Applicable L/T Sheets**

For an update list of Corendon Airlines Aircraft and applicable Load and Trim Sheets please contact ground operations department.

**4.2.2. Last Minute Changes**

- a. Action is taken by the ramp agent.
- b. After all last minute changes, Load and Trim sheets must be handed over to the pilot-in command before off-block time.

- c. If the last-minute change is due to an increase or decrease in passenger numbers and baggage counts, the LMC weight shall be calculated as 90 kg per passenger including cabin baggage, and 15 kg per piece for checked/hold baggage.
- d. If last minute change is due to increase or decrease on checked baggage number (unaccompanied by passenger, for passenger LMC refer to first item above), LMC weight will be calculated as 15 kg as standard for each piece of baggage if actual weight cannot be determined.
- e. If last minute change is due to cabin baggage of a passenger to be carried in the hold because of the overweight and/or oversize, LMC weight will be calculated as 10 kg as standard for each piece of baggage if actual weight cannot be determined.
- f. If the passenger number exceeds 5 and load exceeds 500 Kgs another Load & Trim Sheet must be prepared.
- g. Before transmitting this message, the ramp agent enters the last minute changes in the "LMC" and "UNDERLOAD" column of the Load & Sheet copy. He shall ensure that,
- The total weight of "Last Minute" on-load does not exceed the weight shown under "UNDERLOAD"
  - The center of gravity remains within limits
  - The load limitation of the compartment/position as well as the maximum combined cumulative and/or lateral unsymmetrical loads are not exceeded,
  - In case of takeoff fuel changes (TOW adjustment) the basis for the weight under a, b, c (allowed weight for takeoff, lowest of a, b, c) will not be changed.
  - During any phase of operation, the loading, the load and center of gravity complies with limitations specified in the G.O.M

#### 4.2.3. Abbreviations Used in Regard with Load and Trim Sheet

<b>AOG</b>	Aircraft spare parts required for aircraft on ground; followed by their loading position e.g. AOG/1
<b>AVI</b>	Live animals, followed by their loading positions, e.g. AVI/1
<b>BED</b>	Installed stretcher; followed by the total number of seats blocked stretcher, the number of passengers (incl. invalid) traveling on these seats, e.g. BED/9/2BEH
<b>BEH</b>	Stretcher in hold; followed by its loading position and weight, e.g. BEH/4/40
<b>COM</b>	Company mail; followed by its loading position and weight, e.g.
<b>CSU</b>	Catering Service Unit in compartment; followed by its loading position and weight, e.g. CSU/1/80
<b>EAT</b>	Foodstuffs / edible items for human or animal consumption; followed by its loading position e.g. EAT/1
<b>EIC</b>	Equipment in compartment; followed by its loading position and weight, e.g. EIC/1/30
<b>HEA</b>	Heavy cargo items of 150 kg or more in a bulk-compartment; followed by its loading position and weight, e.g. ICE/1
<b>HUM</b>	Human remains in coffins; followed by its loading position and weight, e.g. HUM/1/130
<b>ICE</b>	Dry ice; followed by its loading position, e.g. ICE/1
<b>MAG</b>	Magnetized materials; followed by its loading position and weight, e.g.
<b>NIL</b>	No items listed
<b>PEF</b>	Perishable cargo (plants & Plant products) followed by its loading position, e.g. PEF/EAT/4
<b>PEM</b>	Perishable cargo (meat & meat products); followed by its loading position, e.g. PEM/4
<b>PES</b>	Perishable cargo (fish & seafood), followed by its loading position, e.g. PES/4
<b>RCL</b>	Cryogenic Liquids; followed by its loading position, e.g. RCL/41
<b>RCM</b>	Corrosive; followed by its loading position, e.g. RCM/11
<b>RFG</b>	Flammable Compressed Gas; followed by its loading position, e.g. RFG/43
<b>RFL</b>	Flammable liquid; followed by its loading position, e.g. RFU/43
<b>RFS</b>	Flammable Solid; followed by its loading position, e.g.
<b>RFW</b>	Dangerous when wet; followed by its loading position, e.g. RFW/43
<b>RIS</b>	Infectious substance; followed by its loading position e.g. RIS/43
<b>ROX</b>	Oxidizer; followed by its loading position, e.g. ROX/41
<b>RP</b>	Toxic; followed by its loading position, e.g. RPB/41

- RPG** Toxic Gas; followed by its loading position, e.g. RPG/41
- RSC** Spontaneously Combustible; followed by its loading position, e.g. RSC/41
- RXS** Explosive 1.4 S; followed by its loading position, e.g. RXS/41
- RSB** Polystyrene Beads; followed by its loading position, e.g. RSB/1/15

### 4.3 COMMUNICATION SYSTEM

An effective communication system shall ensure the exchange of operational information throughout all areas of our organization, and includes senior managers, operational managers and front line personnel. To be totally effective, the communication system shall also include external organizations that conduct outsourced operational functions.

The Ground Operations Department is responsible to supply communication with all of these suppliers (Handling Companies, Catering Companies, Duty Free Suppliers, Fuel Companies, etc...) that enables an effective exchange of safety and operational information relevant to the conduct of ground handling operations throughout the management system for ground handling operations and in areas where ground handling operations are conducted by e-mail, SERA reporting system, SITATEX, fax, telephone, operational reporting system, memos, bulletins, publications, etc..

Issued schedules and revisions, special requests and other information shall be forwarded to related suppliers by ground operation supervisors immediately after receiving the info from commercial or other related departments.

Whenever a verbal transmission is necessary, the following ICAO-International Spelling Alphabet shall be used:

A Alpha	H Hotel	O Oscar	V Victor
B Bravo	I India	P Papa	W Whiskey
C Charlie	J Juliet	Q Quebec	X X-Ray
D Delta	K Kilo	R Romeo	Y Yankee
E Echo	L Lima	S Sierra	Z Zulu
F Foxtrot	M Mike	T Tango	
G Golf	N November	U Uniform	

#### 4.3.1. Flight Movement Messages

In order to the control a punctual and a regular aircraft rotation, it is necessary to send receive flight movement messages. All Stations shall transmit arrival, departure or delay message to all parties. All times must be given in UTC.

a. Priority of IATA type messages are as follows:

**QS: only for message concerning the safety of human lives relating to aircraft accidents/incidents.**

**Never use this priority indicator for other types of messages. This will be checked by SITA.**

**QU:** To be used only for movement, Delay, AOG messages and for matters of extreme urgency

**QX:** Same as **QU**

**QD:** to be used for all type o messages

b. All aircrafts will utilize the priority code QD whenever messages are of a non-operational or urgent type.

c. All aircraft movement message will be sent with QD priority and aircraft movements will be accompanied with an arrival/departure signal. These signals will be composed in a standard format and will be dispatched within 15 minutes of the arrival and or departure of every flight.

d. Signals are to be sent using the SITA network where possible.

e. The following details will be included in the SITA message:

i. **AA:** Actual time of arrival consisting of a time of touch-down actual time, when the aircraft come to rest (ON BLOCK)

ii. **AD:** Actual time of departure, consisting of actual time, when the aircraft starts to move, either by it is own power or push back. (OFF BLOCK)

iii. **EA:** Estimated time Arrival

- iv. **ED**: Estimated time departure
- v. **NI**: time when given the information will be given in case of indefinite delays.
- vi. **MVT**: Message identifier
- vii. **ETA**: Estimated arrival time
- viii. **DL**: Delay time
- ix. **SI**: Supplementary information
- x. **PASSENGER**: Passenger numbers
- xi. **INF**: Infant number
- xii. Flight number, date, A/C registration, airport of departure

f. The departure message must be copied to the alternate airport. The scheduled airport of destination must be copied in the arrival message.

#### 4.3.2. Delay Messages

a. NI and/or ED messages must be sent, whenever the scheduled time of departure is exceeded 15 minutes.

b. The delay in plain language (codes and abbreviations must not be used) under SI. And details whether passenger released. If the estimated time of departure advised in the delay message is likely to be exceeded again, an additional message must be sent stating a revised estimated time of departure.

#### 4.3.3. Example of MVT-Message

Departure message for multi sector flight  
MVT  
CAI449/10.TCTJJ  
AD0920/0925 EA 1017 IST  
PX040/105

MVT  
CAI021/16.TCTJG.AYT  
AD2340/2347 EA0300 AMS  
DL93A/0020  
PX148+00

**IMPORTANT NOTE** for door closing time:

- All turnaround process will be 00:45 minutes regardless of the ground time which is specified in the commercial schedule. All operational processes will be carried out with the aim of closing doors within 00:45 minutes.
- The door closing time (first flight of the day) for all base departures will be carried out with the aim of closing doors 00:15 minutes before STD.
- Please contact with [groundoperations@corendon-airlines.com](mailto:groundoperations@corendon-airlines.com) for any doubt.

#### 4.3.4. Delay Codes

For delay notifications in the departure message, the following delay codes shall be used to best describe the cause of the delay (not the consequence).

Please also state the delay reason in the SI section for delay codes without a subsection.

For CAI-CXI flights, only Corendon delay codes must be used. The delay codes and subcodes can be found in the “Corendon Delay Codes with Sub-Codes” table which is shared Ground Handlings via

<https://handling.corendonairlines.com> .

**Note:** TOF must be specified at all MVT Message Movement and all other operational messages (MVT, PSM, PFS, SOM, LDM) must be sent not later than ATD + 10 minutes (after airborne time), including passenger figures, baggage details, and special requirements. After ATA the movement must be sent no later than 5 minutes.

### 4.4. OTHER MESSAGE FOR LOAD CONTROL AND INFORMATION

#### 4.4.1. Load Message (LDM)

a. The load message shall be transmitted

- i. For all multi sector flights to the next station except the last station of the multi sector flight
- ii. To the alternate station, landing at the next scheduled destination seems doubtful

- iii. From the scheduled destination station to the alternate station, if the aircraft is diverted during flight.
- b. The load message will be completed by transferring all load details, into the shaded boxes of the Load & Sheet for every destination of the flight in the sequence of routing. Last Minute Changes must be considered in the load message.
- c. The station dispatching the load message is responsible for the correct transmission of the message. A cross check therefore shall be made between the load sheet and the copy of the teletype load message. In case of discrepancies a second message shall be sent giving the appropriate correction. In this case the indication "corr. Version" (correct version) shall be stated in the message.

**Example:**

LDM  
CAI661/16. TCTJB.Y148.2/4  
-FRA.140/08/00.T3308.1/100.2/1234.3/1974.PAX/148.PAD/00.B3208.C100.M0  
SI RMOB/148  
WCHC O/B

*Note: if necessary in complicate loading use net sector numbers.*

**4.4.2. On Board Message (O/B)**

If any special load planned and loaded to Corendon Airlines aircraft, handler should send O/B message after aircraft departure immediately as showed at below

**Example:**

O/B  
XC041/31  
-EIN  
AVI/1/25  
-AMS  
CGO/1/161/ACPARTS  
CGO/2/268/ACPARTS  
CGO/3/1136/TEXTILE  
COM/1/5

**4.4.3. Passenger Transfer Message (PTM)**

Passenger, holding confirmed (**OK**) or requested (**RQ**) reservation on a connecting flight within 24 hours after scheduled arrival have to be recorded numerically and divided into destinations.

**Example:** QU AYT0P7H AYTDC7H  
ATYCOXH YT/151400  
PTM  
CAI220/15  
CAI330 HAM C01 B02  
CAI440CDG F02 B07

(B=No of baggage, C/M=class of transportation and No of passengers)

**4.4.4. Passenger Service Message (PSM)**

- a. The PSM shall inform the destination station of a flight of;
  - i. Children traveling alone (UM)
  - ii. Incapacitated passenger
  - iii. Deportees
  - iv. Returned inadmissible passengers

Who will be disembarking at such destination station?

- b. Each boarding station has to dispatch a separate PSM to each subsequent destination station of the flight. PSM to be sent when a TPM is sent to such station.

**Example:** QU DUSSDHL= disembarking station  
AYTCOXH= boarding station  
PSM= message identifier

**CAI550/20**=flight number and date

**SCHUMER**=UM aged 7

**GENCHER**=UM aged 9

**KISKY**= non-ambulant passenger

**WOJTEC**= disabled passenger

#### 4.4.5. Tele Type Passenger Manifest

a. Where a "Passenger Manifest" is required, the boarding station may, in lieu of the form "Passenger Manifest" transmit relevant passenger names to the responsible destination station by teletype message.

b. The TPM shall only use with prior consent of Corendon airlines SITA Addresses (TBA). In this case, a "Teletype passenger manifest" (TPM) shall be sent this also includes those details which would otherwise have to be included in a PTM and a PSM therefore, if a TPM is dispatched, neither PTM nor PSM needs to be send.

c. Contents shall be as follows:

- i. **Surnames of all passengers who have been checked in by the dispatching station to station which the TPM is addressed. Each passenger is to be shown in a separate line of the TPM, however 2 or more passengers of the same family with the same name traveling to the destination may be combined in one line, e.g. "3 KINSKY 1 /INF"**
- ii. **Together with the passenger who have been checked in by the dispatching station of the respective service code.**
- iii. **BLND, DEAF, WCHR, WCHC, BED, UM shall be stated.**
- iv. **Passenger seat numbers shall be stated**
- v. **Passenger baggage details shall be stated**
- vi. **Passenger manifest shall be send to [manifest@corendon-airlines.com](mailto:manifest@corendon-airlines.com) after each flight.**

#### 4.4.6. Seat Occupied Message

Recommended that, member shall use the following message format when informing the next down line station (own station or other member acting as handling agent) of seats occupied on the aircraft.

**Example:**

SOM

CAI731/18AUG AYT

-SXF.02ABC 03C 04ABC 05ABC 08ABCD 09ABC 10ABC 12C 14ABC 15ABC

16CD 18CD 20ABC 21ABC 22ABC 23BC 24ABC 25ABC 26ABC 27ABC

28ABCD 29ABCD 30ABCD 31ABC 32AB

-STR.01ABC 02DEF 03ABDEF 04DEF 05DEF 06ABCDEF 07ABCDEF 08EF

09DEF 10DEF 11ABCDEF 12ABDEF 14DEF 15DEF 16ABEF 17ABCDEF

18ABEF 19ABCDEF 20DEF 21DEF 22DEF 23DEF 24DEF 25DEF 26DEF

27DEF 28EF 29EF 30EF 31DEF 32CDEF 33ABCDEF

SXF|32+02 STR|116+00 TOB|148+02

#### 4.4.7. Ad-hoc Schedule Message (ASM) And Flight Disposition Message (FD)

a. Amendments and alterations to the basic schedule published in the bi-weekly flight program 72 hours and more prior to a schedule or planned departure time, will be published by CORENDON AIRLINES SITA Addresses by means of an ASM. These publications refer in general additional flights, time / routing changes of flights as well as flights equipment changes (aircraft changes) for commercial and operational reason.

b. The sector mentioned in ASM is replacing parts of the published schedule.72 hours before a scheduled is concerned is taken over by the traffic center CORENDON AIRLINES SITA Addresses The traffic center is responsible for the regular, punctual and economical operation of all CORENDON AIRLINES services. Disposition, necessary traffic, are published by means of the Operation Control Center (OCC).

**Note:** Since 02th of February 2012 Turkish Civil Aviation Authority created a new unit for the messages of TC registration airlines flights. Please add "**ANKGMYF**" address to your folders (MVT, LDM, PSM, PTM etc.), that all related with our company. (Corendon Airlines/CAI),

c. Unspecified optional data elements in connection with all action codes except NEW, CNL, RPL remain unchanged from previously supplied data. Where desired, removal of such data is achieved by specification of text "NIL"

d. The contents of a FD can refer to:

<b>ACH</b>	<b>AIRCRAFT CHANGE</b>
<b>ADD</b>	<b>ADDITIONAL FLIGHT ("R" ADDED TO FLIGHT NUMBER WHEN FLIGHT WAS CANCELLED)</b>
<b>CCH</b>	<b>CREW CHANGE</b>
<b>CXX</b>	<b>CANCELLATION</b>
<b>DIV</b>	<b>DIVERSION OF FLIGHT (AT AIRPORT OF DIVERSION)</b>
<b>TERM</b>	<b>FLIGHT TERMINATING</b>
<b>CONTG</b>	<b>FLIGHT CONTINUING</b>
<b>NO STATEMENT</b>	<b>DECISION LATER</b>
<b>ECH</b>	<b>EQUIPMENT CHANGE</b>
<b>ISK</b>	<b>INFORMATIVE SCHEDULE (ORIGINAL SCHEDULE IN FORCE, OCCURRING DELAYS SHALL BE BASED ON THE ORIGINAL SKED)</b>
<b>RRT</b>	<b>REROUTING OF FLIGHT</b>
<b>RST</b>	<b>REINSTATING OF FLIGHT</b>
<b>SCH</b>	<b>SCHEDULE CHANGE</b>
<b>OVCH</b>	<b>VERSION CHANGE</b>

e. Additional information, which cannot be covered with the above codes, the reason for the transaction will be stated:

<b>T</b>	<b>TECHNICAL REASON</b>
<b>R</b>	<b>ROTATION</b>
<b>O</b>	<b>OPERATION</b>
<b>S</b>	<b>SALES</b>
<b>W</b>	<b>WEATHER</b>
<b>H</b>	<b>HANDLING</b>

**Example: ASM**

GMT/AYTTT/001

NEW CAI 001

21 DEC 02 2P 73V C148

BF 120 1600 YFB202100

SI: delivery Flt. TC BASIC MESSAGE ADDRESSE

All Corendon Airlines aircraft movement messages, including sub chartered arrival or delay message has to be copied to:

CORENDON AIRLINES MESSAGING ADDRESSES and REQUIRING MESSAGE TYPES

<b>MVT</b>	AYTOP7H	AYTDC7H	AYTUSXH	AYTKQXH
<b>LDM</b>	AYTOP7H	AYTDC7H	AYTUSXH	AYTKQXH
<b>PSM</b>	AYTOP7H	AYTKPXH	---	---
<b>PFS</b>	AYTOP7H	---	---	---
<b>TPM</b>	AYTOP7H	<a href="mailto:manifest@corendon-airlines.com">manifest@corendon-airlines.com</a>	<a href="mailto:groundoperations@corendon-airlines.com">groundoperations@corendon-airlines.com</a>	---
<b>SOM</b>	AYTOP7H	Next station addresses		
<b>Lost Found</b>	AYTOP7H	AYTLLXC	<a href="mailto:AYTLL@corendon-airlines.com">AYTLL@corendon-airlines.com</a>	AYTLLXH
<b>PNL System</b>	AYTITXC	---	---	---
<b>SSR Originator</b>	AYTOP7H	---	---	---

**Note:** This table is for AYT flights only, for different destinations please request from; [groundoperations@corendon-airlines.com](mailto:groundoperations@corendon-airlines.com)

## 5. CARGO HANDLING

Corendon Airlines will operate cargo operations in accordance with the states' regulations. Also, Corendon Airlines has authorization to carry cargo from/to specified destinations related to ACC3 regulation.

### 5.1. GENERAL

Procedures for the storage of cargo after acceptance and preparation for aircraft loading must provide:

- a. Security in all aspects- not only security of valuable cargo, but reducing to a minimum the possibilities of damage, pilferage and mishandling of all cargo;
- b. Secretion of, and suitable storage facilities for, special types of cargo such as dangerous goods, live animals, perishables vulnerable and valuable cargo;
- c. Methodical and speedy pre-loading operation whereby the entire load may be assembled in accordance with local requirements.

### 5.2. ACCEPTANCE OF CARRIAGE OF CARGO

Corendon Airlines will accept cargo applications according to International Rules as well as IATA and Governmental regulations and is only responsible for correct loading/unloading of the aircraft.

### 5.3. DANGEROUS GOODS

Preparation procedures for aircraft loading Dangerous Goods must be in accordance with IATA Dangerous Goods Regulations. (For more information see Section 8 Dangerous Goods)

### 5.4. LIVE ANIMALS

For live animals please refer Chapter 3.12.9. Loading Procedure / Live Animals.

### 5.5. OTHER SPECIAL CARGO

For other special cargo, such as valuable cargo, perishables, vulnerable cargo, human remains and shipments of special importance or urgency, particular points to be considered are:

- a. That all personnel concerned are made fully aware of the nature and handling requirements of all such shipments,
- b. Suitable arrangements are made for the security of valuable and vulnerable cargo;
- c. Perishable are handled in accordance with the requirements of the particular commodity;
- d. That a check is made to ensure that the final load assembled for dispatch to the aircraft does include shipments of special importance or urgency; ensure that shipments considered as special cargo have "special consignment" labels visibly attached to each package.

#### 5.5.1 Outsized Cargo and Heavy Cargo

Due to the A/C type which Corendon Airlines Operates, the following must be observed:

- Specifications of the aircraft types are in the manual and any outsized cargo which will not fit due to the dimensions will not be accepted under any circumstances, so please ensure that the dimensions of the aircraft are observed to avoid any confusions.
- If the outsized cargo does fit the specifications then the handling agent loading the aircraft must be advised before flight to ensure proper stowage of the cargo. The mentioned cargo shall be loaded, secured and unloaded in accordance with IGOM 4.5.7 and 4.5.8. Aircraft load and restraining limitations shall not be exceeded. Lashing of heavy and oversized cargo is done using relevant

materials and limitations for such materials are not exceeded. Any Special Cargo outside the ones mentioned in the manual must be checked with the Cargo Management for approval and acceptance, as no special cargo will be accepted without approval from Corendon Airlines.

- **Heavy Cargo** is defined as a load which exceeds 150 kg per unit and that are voluminous, vulnerable and difficult to handle. Corendon Airlines does not accept Heavy Cargo.

Note: Please see Chapter 6 of this manual for the aircraft dimension details.

### 5.5.2 Live animal

Live animal handling procedure and specific responsibilities with regard to required documentation, acceptance, animal welfare, compliance with all regulations, storage and loading and liability are referenced to IATA LAR. Additional requirements can be mandated by the State of departure and/or CITES. With the reference of above, Corendon Airlines accept PETC and AVIH if the passenger performs all the conditions regarding to Ground Operation and Cargo Operation Manuals requirements. However, the following regulations apply to loading live animals:

- It must be accepted that live animals are delivered for shipping in proper cages, complying with the IATA Live Animal Regulations (LAR).
- Operation of the aircraft air conditioning system is checked in relation to the regime of transportation specified in the LAR to avoid the possibility of a "fog" phenomenon that can result in moisture accumulation, which in turn can cause corrosion and possible activation of fire sensors in flight.
- Cages are checked for visual damage and are locked to prevent animal escape during flight.
- Drinking bowl is affixed to prevent water leakage during any stage of flight.
- The NOTOC includes live animal shipments as a special load and includes the required action for control of hold heating/ventilation.
- Mollusks (worms etc.), amphibians (frogs etc.), fish (except tropical fish) and snakes may be loaded in all cargo compartments without restrictions.
- All other live animals shall be loaded in the prescribed compartments. Heating /cooling any compartments in the aircrafts (B737-800) operating with the transaction of cabin ventilation.
- Live animals shall generally be treated as wet freight. The cages shall always be tied down or lashed to avoid any movements during takeoff, flight or landing.
- Cages shall be stowed with sufficient space between them and other loads to guarantee sufficient supply of air. Do not fill the compartments to more than 2/3rd of their volume.
- Cages must not be stowed directly in front of air ventilation outlets or in direct contact with outer compartment walls.
- Live animals shall not be loaded in the same compartment with eatable cargo (EAT), catering supplies (CSU), human remains (HUM) or dry-ice (ICE) in larger quantities.
- Special care must be taken not to stow live animals, which are natural enemies in the same cargo compartment. If unavoidable, sufficient space shall be left between them to avoid mental stress.
- Cargo compartment lights shall generally be switched off, except when carrying birds on long-haul flights. Then the light shall be left switched on, if possible, to allow the birds to pick-up their feed during the flight.
- The doors of cargo compartments with live animal loads shall be closed as late as possible and opened at transit and/or destination stations first; special care must be taken in case of strong winds, heavy rain, snowfall and extreme local temperature conditions.

- Due to their sensibility against low temperatures and special handling requirements, the shipper is held responsible for insulated packing according to IATA Live Animal Regulations.
- Transportation of tropical fish is subject of the following conditions:
- Transportation to and from aircraft shall be performed as quickly as possible. In case of low ground temperatures, heated transport shall be used (ramp vehicle).
- Tropical fish shall principally be loaded in heated compartments. The transportation in unheated compartments in excess of one-hour flying time is prohibited.

#### **5.5.2.1 Live Animals Acceptance Check List**

According to responsibilities of cargo handling, cargo handling company shall fill the current edition of IATA LIVE ANIMALS ACCEPTANCE CHECK LIST.

#### **5.5.2.2 Shipper's Certification for Live Animals**

Before any package containing live animals is tendered for transport by air, shipper must ensure that:

- The animals being tendered for transportation are not prohibited by governments
- All the required export, import and / or transit health certificates, licenses or permits, etc. are accompanying the shipment in accordance with IATA LAR.
- Additional requirements can be mandated by the State of departure and/or CITES.
- The animal shipments are properly classified, described packed, marked and labeled
- The current edition of IATA Shipper's Certification for live Animals must be properly completed in duplicate
- Pregnant animals must not be tendered for transportation without official veterinary certificate certifying that the animals are fit to travel and that there is no risk of birth occurring during the entire journey
- No animals are to be tendered for transportation having given birth in the last 48 hours before the start of journey
- The animals have been properly prepared for transportation
- The animals are not tranquilized without veterinary approval and supervision
- The consignee has been advised of the flight details in order to arrange immediate collection on arrival
- A 24-hour phone number that the air carrier can obtain instruction from the shipper or his agent in the event of an emergency, and such information is written on the Air Waybill.

#### **5.5.3 Perishables**

Perishable goods are such, whose conditions or suitability for its original or prime purpose may deteriorate below its useable condition if exposed to undue changes in temperature and humidity or delayed in transportation (e.g. fresh fruit and vegetables, flowers, meat and fish shipments, vaccines, medical supplies etc.). Due to individual procedures being applicable for different perishable goods, the following different load information codes are used:

- Foodstuffs - food for human or animal consumption (EAT)
- Hatching eggs (HEG)
- Live human organs (LHO)
- Flowers/plants (PEF)

- Meat (PEM) and seafood/fish (PES) shall be handled as WET
- Fruits and vegetables (PEP)
- All perishable goods other than flowers, meat, seafood or fish (PER)

Perishable cargo requiring special attention during flight, e.g. recommended temperatures and/or ventilation, shall be entered in the remarks box of the Load and Trim-sheet. In case of thermographs (shipper owned) being used in temperature sensitive loads, the cargo department shall inform the aircraft handling department accordingly, a respective remark for en-route transit, and destination stations shall be entered in LDM and loading position.

### **Loading**

Perishable cargo shall be accepted for carriage only if properly packed in order to avoid damage and/or contamination to other loads or compartments. Corendon Airlines accept Perishables in accordance with the conditions regarding to Ground Operation and Cargo Operation Manuals, IATA Perishable Cargo Regulations (PCR) and other applicable regulations. Additional requirements may be mandated by local regulatory authorities and Corendon Airlines will accept this kind of regulations. Perishable cargo, refrigerated with wet ice or containing fluids or moisture which could leak (e.g. meat, fish or other seafood - fresh, salted, smoked or frozen) shall be treated as "Wet Cargo". Perishable cargo, refrigerated with dry ice (ICE) shall be handled according to the respective regulations. Care shall be taken when stacking perishable items so that lower layers of the stack are not damaged by the weight of the upper layers.

### **Handling in delay situations**

In the event of a delay, actions shall be taken to prevent a deterioration of the loads, such as:

- Provision of air condition to the aircraft.

Transferring the perishable cargo to a warehouse with adequate facilities, such as air conditioning or cold store. Offloading and rebooking control and refilling of dry ice supply.

#### **5.5.3.1 Foodstuffs (EAT)**

Foodstuffs shall not be loaded together with poisons (RPB) or infectious substances (RIS) in the same compartment, unless they are loaded in separate ULDs not adjacent to each other. Foodstuffs shall not be loaded in close proximity of live animals (AVI) and human remains (HUM).

#### **5.5.3.2 Hatching Eggs (HEG)**

Hatching eggs shall not be stowed in close proximity of dry ice (ICE) and cryogenic liquids (RCL). The temperature in the compartment should remain between 10°C and 15°C during flight and should not exceed 27°C.

#### **5.5.3.3 Vaccines, Medical Supplies and Live Organs (LHO)**

Life-saving drugs or live human organs (LHO), which have been requested on short notice, shall principally be loaded in the special collecting net for small cargo items. In special cases, considered justifiable by the Stations Manager or his/her deputy, in relation to given specialties of transportation,

These shipments may be given into the care of the cockpit crew (PIC). In all cases a copy of the request, the delivery document or the telex message showing the description of the drug or human organ, the names of the final recipient and the person collecting it from the aircraft shall be handed to the cockpit crew (PIC).

According to the priority regulation of the "Federal Institute of Traffic Control" ATC, precedence is given to a flight carrying life-saving drugs or live human organs, respectively in a life-saving mission. In such cases, the priority shall be requested by the cockpit crew (PIC). Notice of such requests shall be given to AYTOP7H

**Note:** In case of transport without reference to an emergency, the priority regulation does not apply.

**5.5.3.4 Flowers/Plants (PEF)**

Flowers shall be stowed so as to avoid direct contact with the compartment floor or walls. Flowers should not be stowed in the same hold or ULD as fresh fruit and vegetables (PEP) due to ethylene gas produced by vegetables which may deteriorate flowers.

**5.5.3.5 Meat and Seafood/Fish Shipments (PEM/PES)**

- Fresh or frozen meat, fish or seafood with or without dry ice may be carried on passenger aircraft when the special restrictions are observed:
- The structure of the compartment shall be protected by tarpaulins or plastic sheeting and insulating material against direct contact with the load.
- Dry ice for cooling must be considered as dangerous goods.
- For loads of 100 kg meat no more than 2 kg dry ice shall be used for cooling. For larger quantities of meat, the quantity of dry ice shall be increased in proportion.

**Note:** Experience has proven that 5 kg dry ice per 1.000 kg of meat is normally sufficient. The crew is to be informed of the special load in writing.

**5.5.3.5.1 Temperature Requirements for Meat and Seafood/Fish**

- The temperature ranges to be maintained are:
- Fresh meat between 0°C and 5°C
- Fresh fish not to exceed 5°C
- Frozen meat below -12°C
- Frozen fish not to exceed -12°C this will require use of refrigerated/temperature controlled container.

**5.5.3.5.2 Loading as Bulk Cargo**

The loading shall be prepared in the following sequence:

- The cargo compartment is cleared of all items not required for loading.
- The tie-down rings as required for the load are fitted into the tie-down track in the compartment floor.
- Lashing ropes and/or straps shall be attached to the tie-down rings and laid out along the compartment walls.
- Absorption sheets are laid out on the floor.
- Tarpaulin or plastic sheet shall be laid out and tied to the fastening.

**Note:** Fastening bolts shall only be used for tying tarpaulins, due to their limited strength; they cannot be used for tying down loads.

- Loading being completed, the tarpaulins are pulled over the load. The open part of the tarpaulin facing the cargo door shall be folded and also pulled over the meat.
- Lashing material (straps or ropes) are accessible now and shall be fastened across the shipment and secured properly.
- Boxes with dry ice shall be suspended from the ceiling outside the tarpaulin covering for cooling the whole compartment

### 5.5.3.6 Fresh Fruit and Vegetables (PEP)

When fresh fruit and vegetables are loaded, care shall be taken to ensure that space for air circulation is left between packages. This is of particular importance to fresh fruit and vegetables having high moisture contents (e.g. grapes, berries, salad etc.). Fresh fruit and vegetables should not be stowed in the same hold as flowers (PEF).

### 5.6. COMPANY MAIL AND COMPANY MATERIAL (CO-MAIL & CO-MAT)

The transportation of such co-mail/co-mat is allowed on condition that:

- Co-mail and Co-mat shall be screened properly before transporting.
- It is packed, stored and transported under the supervision of their own staff.
- Co-mail and Co-mat shall be tagged with Corendon Airlines Co-mail and Co-mat forms and be delivered with Co-mail and Co-mat delivery form.
- It is free of any objects or contents which could be hazardous to air transportation.
- It is within the acceptable dimensions (for cabin and cargo compartment).
- Pilot in Command is authorized to refuse the acceptance of co-mail unless he/she has examined the co-mail personally.
- Co-mail and Co-mat may only contain articles relating to official airline or tour operator business. Private mail, tobacco, alcoholic beverages, duty free articles and food items are not permitted.
- Every piece must clearly state: full name and address of sender full name and address of addressee, flight number, date of flight and routing description of contents pieces and total number.
- Co-mat (packages or parcels containing company materials) may be presented at check-in by the tour operator representative or Corendon Airlines representatives only.
- The co-mail / co-mat must be provided with a co-mail/co-mat tag. The tag shall have the following information: flight number with date, destination, origin and weight of co-mail/co-mat.
- Pilot in Command shall be informed about Co-mat details such as content, dimensions, weight etc.
- The co-mat shall be treated as baggage, however, for the documentation the weight must be included in the mail figures on the loading instruction and load sheet
- After arrival at the destination airport, the co-mail/co-mat will be delivered to the baggage claim.
- Co-mail / Co-mat tags and Co-mail delivery form can be ordered via stationary request.

### 5.7. RESPONSIBILITIES

Corendon Airlines or its handling company shall ensure; qualified personnel carry out the above procedures. It is recommended that the signature of the person responsible for preparation of the load be recorded.

Please refer to Cargo Operation Manual (COM) for detailed information.

**6. AIRCRAFT DATA-QUICK REFERENCE**

**6.1. AIRCRAFT DIMENSIONS**

**Boeing 737-800**

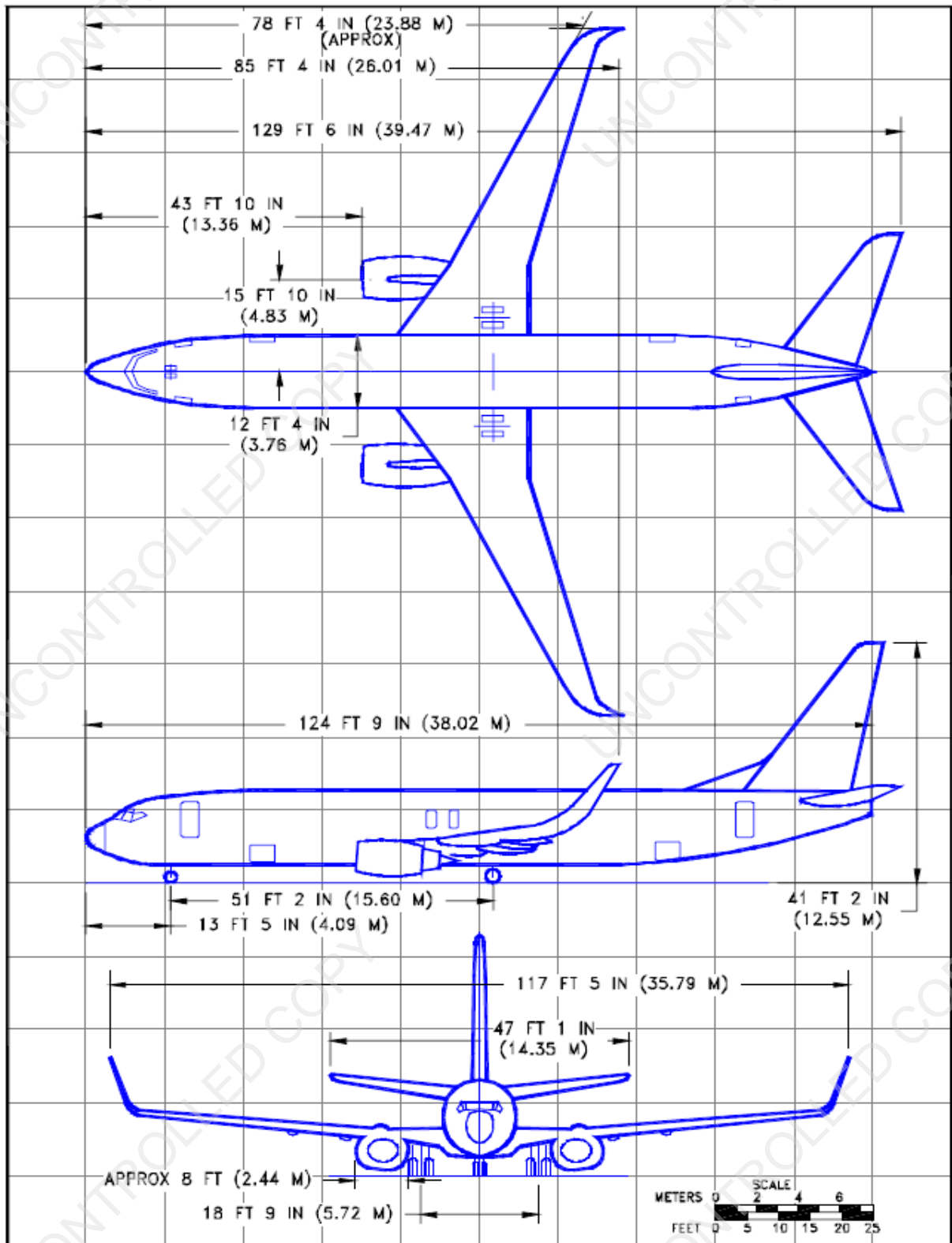

**-Boeing 737-800 (MAX)**

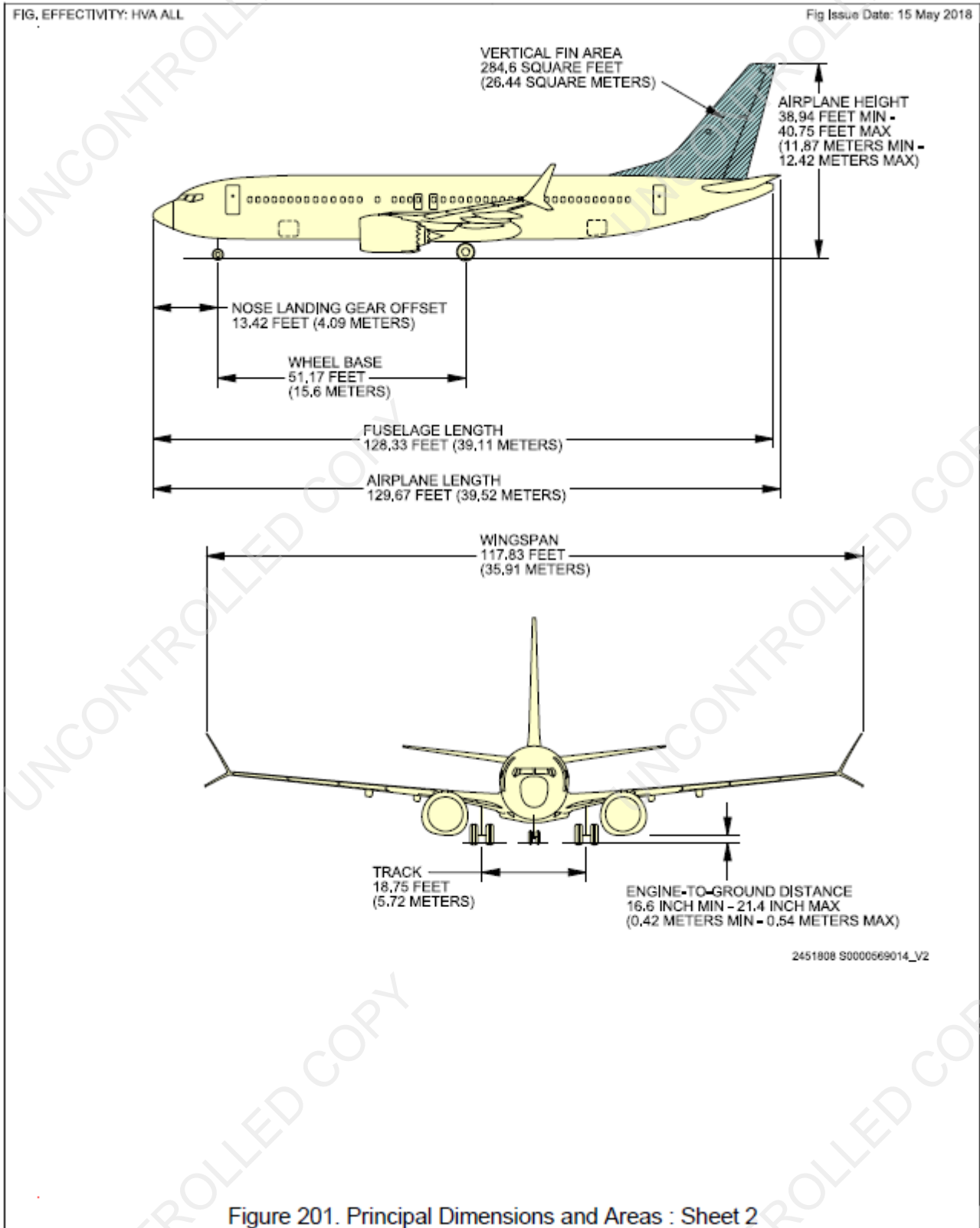

**6.1.1. Baggage / Cargo Compartment Volumes**

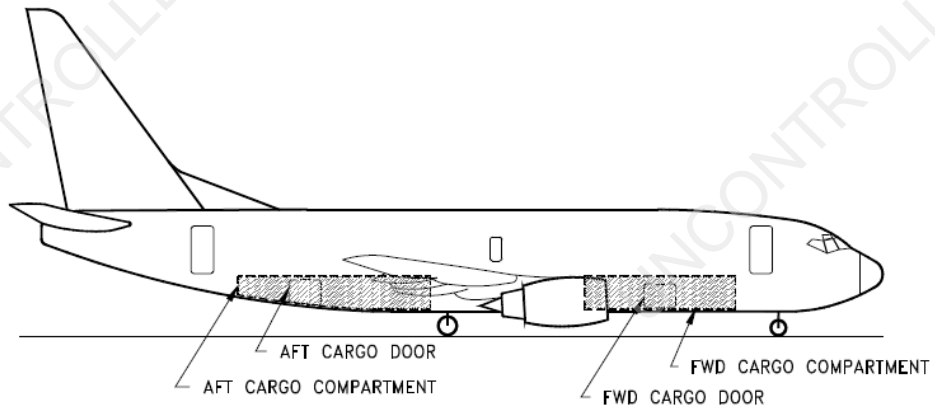

AIRPLANE MODEL	AFT CARGO COMPARTMENT			FORWARD COMPARTMENT BULK CARGO	TOTAL BULK CARGO	NOTES
	BULK CARGO	AUXILIARY FUEL TANK CAPACITY	AUXILIARY FUEL TANK COMPARTMENT CAPACITY			
737-800	899 CU FT (25.5 CU M)	0	0	692 CU FT (19.6 CU M)	1,591 CU FT (45.1 CU M)	(1)

**\*For details see AHM-560.**

**\*For additional details regarding Boeing 737-800 Max, see AHM-MAX**

**6.1.2. Cargo Door Dimensions**

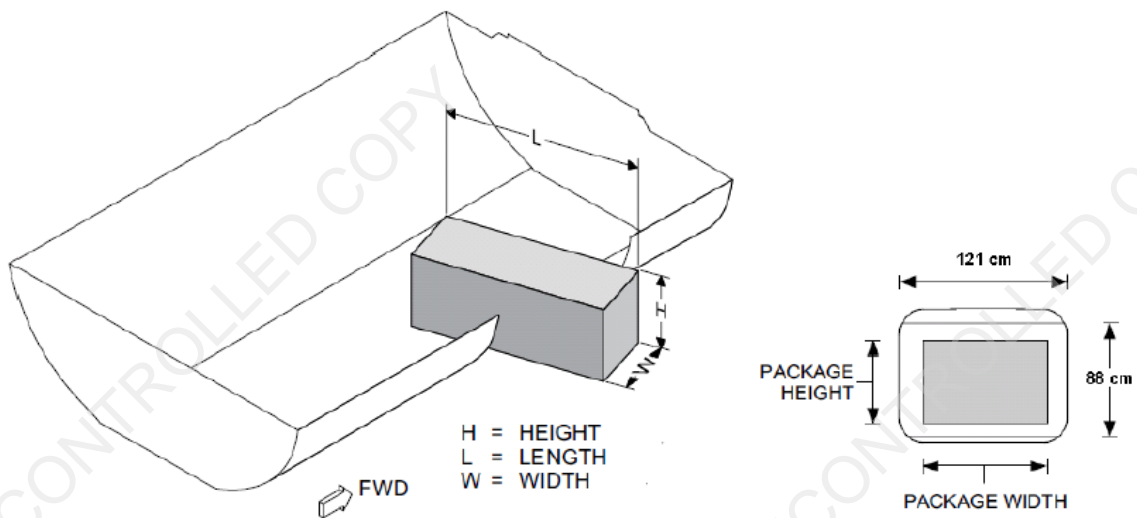
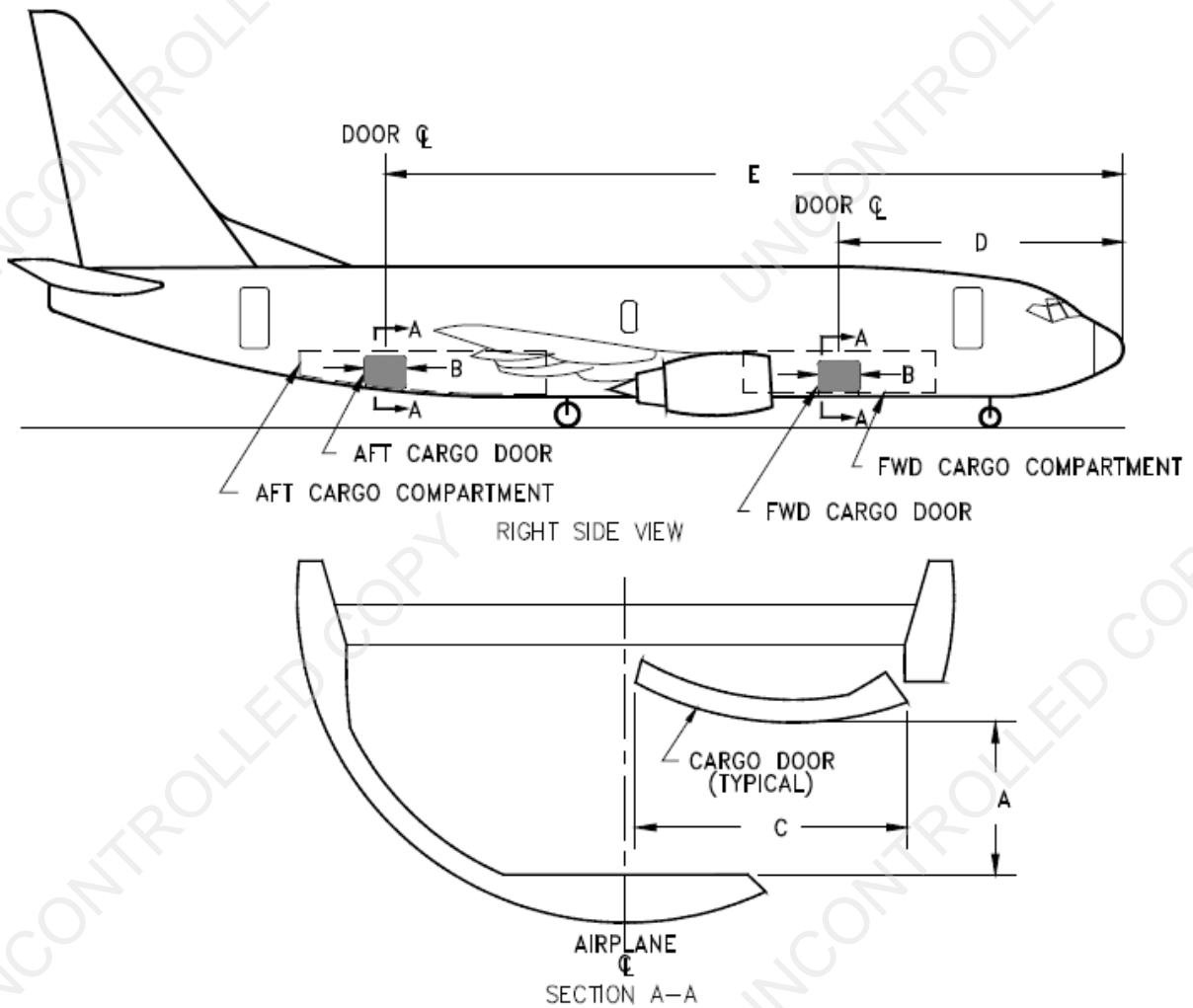

FORWARD CARGO DOOR			AFT CARGO DOOR		
DOOR SIZE (CxB)	CLEAR OPENING (AxB)	DISTANCE FROM NOSE TO DOOR CL(D)	DOOR SIZE (CxB)	CLEAR OPENING (AxB)	DISTANCE FROM NOSE TO DOOR CL(D)
51 x 48 IN (1.30 x 1.22 M)	35 x 48 IN (0.89 x 1.22 M)	28 FT 0.25 IN (8.54 M)	48 x 48 IN (1.22 x 1.22 M)	33 x 48 IN (0.84 x 1.22 M)	91 FT 8.5 IN (27.95 M)

## 6.2 AIRCRAFT SERVICING ARRANGEMENTS

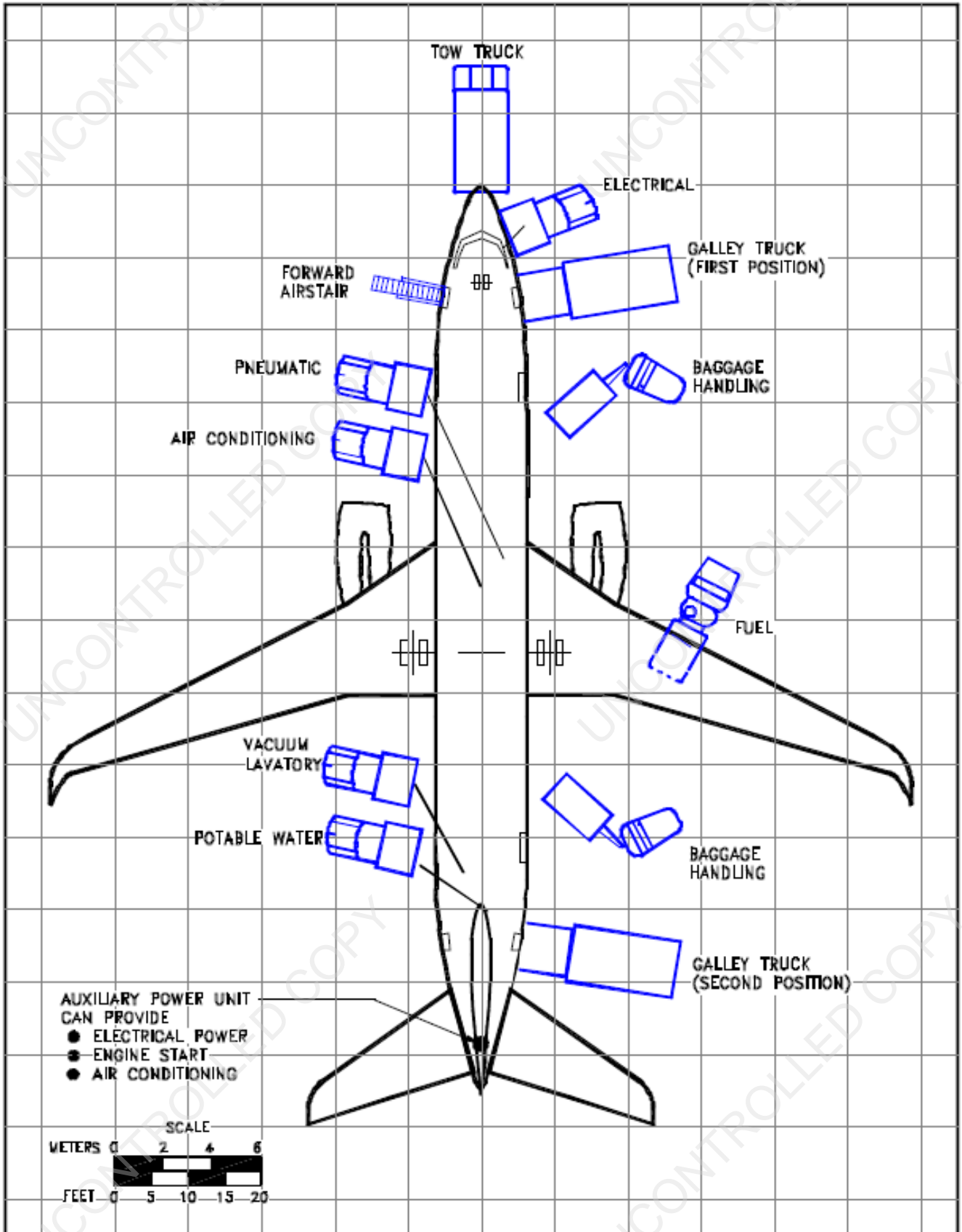

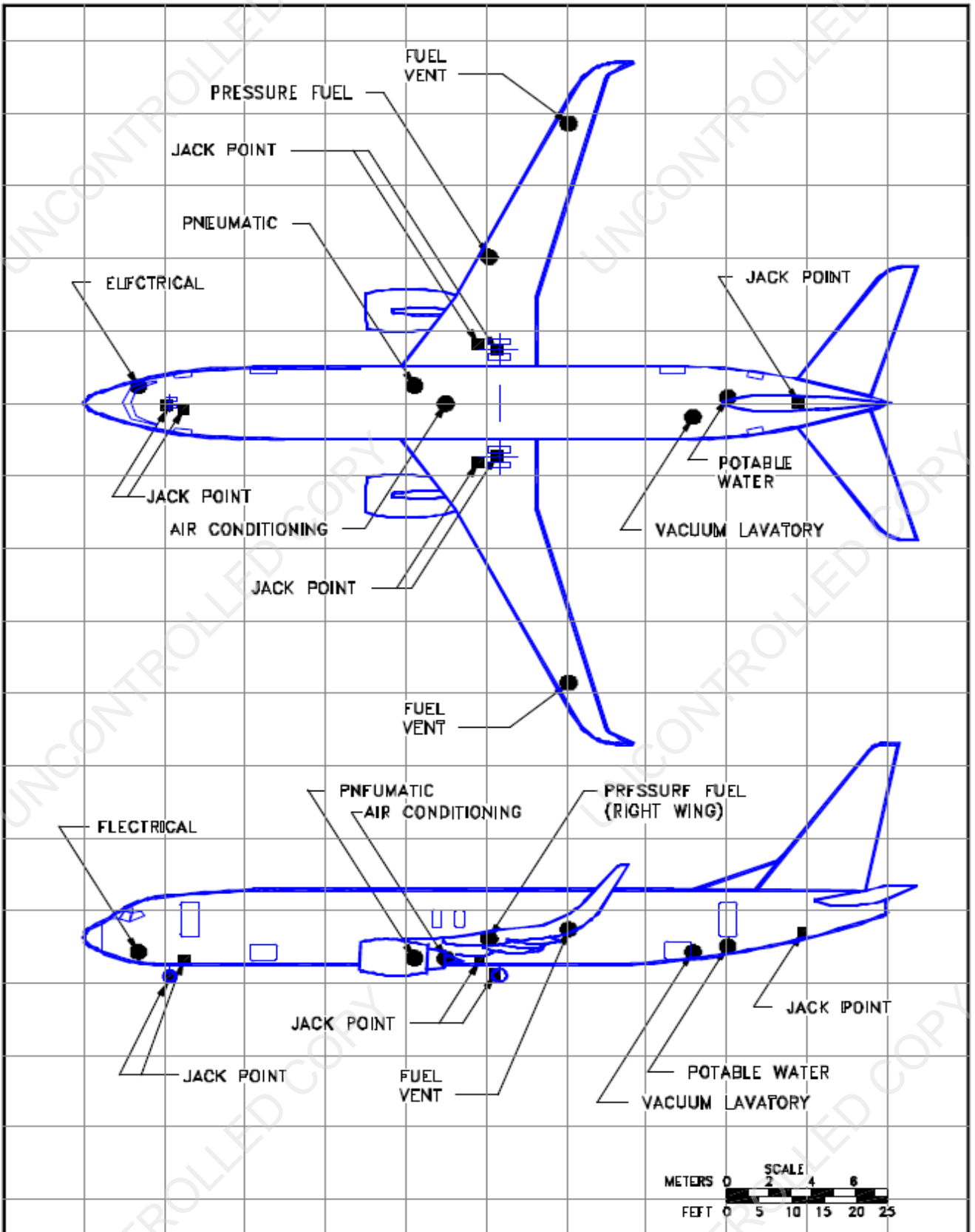

## 6.2. AIRCRAFT GALLEY PLANS

- Oven x 5
- Position 401-3-4-17-19-25-26-27: Single Containers
- Position 418: 1 x Ice Container
- Position 420: 1 x Full Trolley or 2 Half Trolleys
- Position 421: 1 x Full Trolley
- Position 422: 1 x Full Trolley
- Position 423: 1 x Full Trolley
- Position 424: 1 x Full Trolley or 2 Half Trolleys

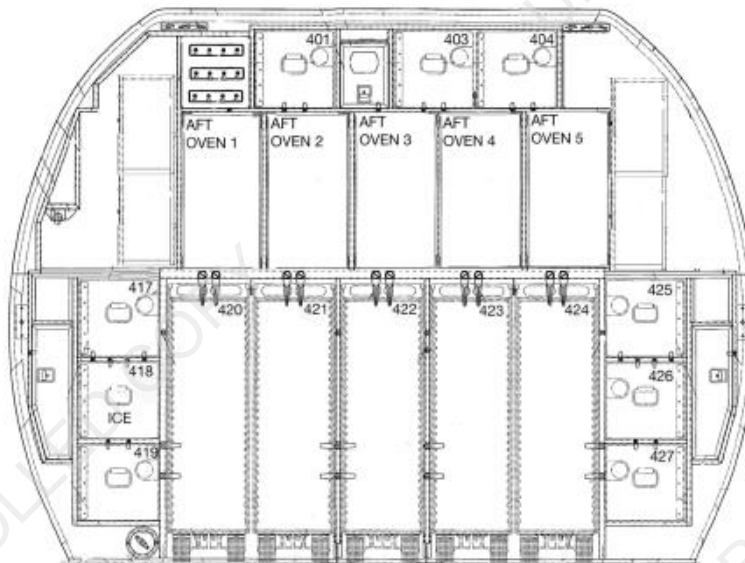

- Oven
- Position 201: Single Containers
- Position 206: 1 x Full Trolley or 2 Half trolleys
- Position 207: 1 x Full Trolley
- Position 208: 1 x Full Trolley

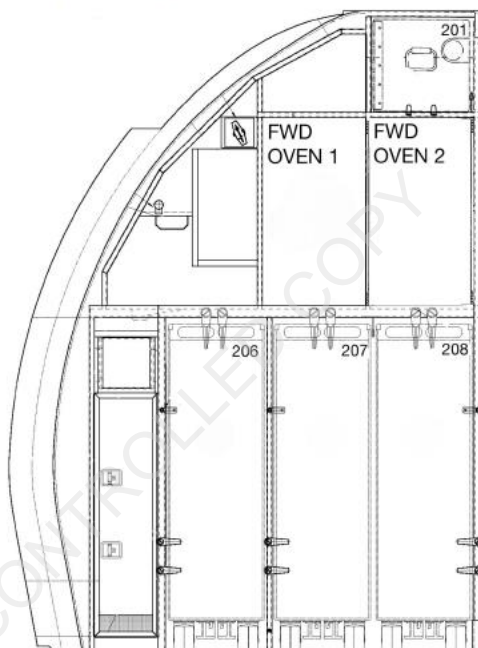

- Position 101: Single Container
- Position 104: 1 x Half Trolley
- Position 105: 1 x Half Trolley

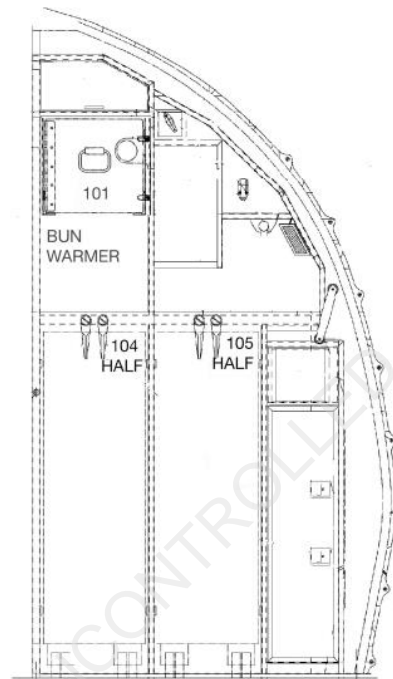

## 7. SECURITY AND ACCIDENT PROCEDURE

### 7.1. SECURITY PROCEDURES

This section contains light instructions for emergency situations such as an incident, bomb threat or hijacking which involves a Corendon aircraft or a flight operated under a CAI/XC call sign. Please see the Security Manual for detailed information.

Keep in mind:

As handling agent or supervisory agent, you represent Corendon Airlines.

Please adhere to the following instructions in all situations:

- Do not give information to anyone except Corendon Airlines.
- Do not admit liability at all time;
- Do NOT speak to the press;
- Refer ALL enquiries to the Corendon OCC.

#### General Instructions

Try to remain as calm as possible in order to help people who may be in an emergency situation.

All emergencies shall be reported directly to the Corendon OCC Phone +90 242 330 3290 or +90 549 412 0078;

- As soon as you are connected, keep the telephone line to the OCC permanently open;
- Do not use a mobile phone; choose a hands-free phone inside an office if available;
- First give the Corendon OCC as much information as possible verbally;
- Additional information can also be sent by SITA and e-mail: SITA: AYTDC7H (use priority code high)  
E-mail: [occ@corendon-airlines.com](mailto:occ@corendon-airlines.com)
- Do not delay passing on the information you have been able to obtain. Send it, and give updates when more information becomes available;
- Listen at least every 30 minutes, on the hour and half hour to the open telephone line with the OCC to check if they are trying to reach you.

#### OCC

Tel: +90 242 330 32 90

Mobile: +90 549 412 00 78

#### GROUND OPERATIONS

Tel: +90 242 330 33 36

Mobile: +90 549 412 00 36

### 7.2. FIRE AND FIRE FIGHTING

Crew should practice fire prevention skills by observing for passenger actions for suspicious behavior, and the immediate elimination of potential fire hazards. In particular, attention should be directed to the lavatories. Make frequent checks of the lavatories to make sure that no smoke is present and there is good housekeeping. Check waste containers for partly open flapper doors for overfull or jammed conditions. These waste containers should also be inspected for discarded objects which could be hazardous, such as cologne bottles or spray cans. Put these objects into the galley waste container. Another area susceptible to fires is the passenger cabin lower sidewall. Flammable items over air grills have ignited unobserved because the return airflow carries smoke and fumes away from the passengers. Maintain surveillance of floor areas, particularly in the smoking zones, to keep clothing, bags, and paper from being deposited where they may be a fire hazard.

For more information, please see Corendon Airlines CCM Chapter 08.02.05 .

**7.3. AIRCRAFT ACCIDENT PROCEDURE**

a. When an aircraft accident or other threat to Corendon Airlines personnel, customers or property are occurred, below contact details are to be called:

**Operation Control Center (OCC)**

**Tel:** +90 242 330 32 90

**Mobile:** +90 549 412 00 78

**Fax:** +90 242 330 35 22

**E-mail:** [occ@corendon-airlines.com](mailto:occ@corendon-airlines.com)

b. Individuals assigned to supervision on-site shall have knowledge of their responsibilities within the local safety plan and emergency response plan for responding to accidents and/or incidents or other emergencies that may occur during aircraft ground handling operations in accordance with local applicable regulations.

c. Chief Operating Officer / Assistant Ground Operations Manager, Ground Handling Contracts can contact the handling company and ask for additional requirements where the accident and/or other threat occurred.

d. Designated handling personnel are aware of their role and duty on the accident site in accordance with ERP.

For more information, please see Corendon Airlines Emergency Response Plan which is published in company web portal <https://handling.corendonairlines.com>

e. Corendon Airlines Ground Operation Personnel should be fully aware of the procedures which apply to their own department.

f. It is the responsibility of the department designated personnel that which documents and/or action checklists should be prepared/followed and provided for the Crisis Document List in case of any emergency situations.

g. The designated Ground Operations Personnel shall be prepared for any situation that effect aircraft, passengers, crew or facilities. As soon as ground staff has informed about potential evacuation, appropriate terminal authority shall be informed and their instructions shall be followed. Cooperation and communication with internally and third parties are very important. When any necessitate of evacuation of passengers from aircraft, ground handling agent shall apply the emergency procedures of local airport authorities. Aircraft evacuation is determined detailed in CCM (cabin crew manual).

**7.3.1 Emergencies Requiring the Evacuation of an Aircraft during Ground Handling**

In the event of an emergency situation occurring during ground handling operations, evacuation of an aircraft may be necessary. The safety of passengers and staff in such circumstances is of utmost importance. The decision and method of evacuation will be dependent on the circumstances and at the discretion of the aircraft commander or designated authority as well as the own procedures of ground handling company.

It is the responsibility of the contracted ground handling company to ensure that all personnel are made aware of their specific responsibilities in the event of an emergency situation. The basic instructions given below shall be fulfilled by the relevant staff in case of emergencies.

**Type of Emergencies****Fuel Spill**

- Activate emergency fuel shut-off (if able to do so)
- Notify the aircraft commander, fire brigade and other necessary emergency services (such as ambulance) and airport authority
- Evacuate all persons, if required

- Contain spill by use of initial spill response kit (if available)
- Verify with authorities/supervisor whether to stop all activity around the aircraft.
- As far as possible, restrict all activities inside and outside the spill area to reduce the risk of ignition.
- Secure the area 15 meters from the contaminated area.

### Aircraft Fire

- Notify the aircraft commander, fire brigade and other necessary emergency services (such as ambulance) and airport authority
- If instructed by or in case of the absence of crew, evacuate passengers and all staff working inside and in the near vicinity of the aircraft
- Attempt to extinguish the fire
- Secure the area

### Dangerous Goods Incident

- Notify the flight crew, fire brigade and other necessary emergency services (such as ambulance) and airport authority
- Evacuate all persons if required
- Identify the nature, source and associated hazard of the contamination.
- Stop the handling activities or reduce them to a minimum in the vicinity of the hazard.
- Prevent access by unauthorized personnel.
- Do not walk through, touch, sniff or taste any substance or spilled material.
- Restrict/block access to the damaged item using any suitable means
- Secure the area, isolate the consignment/baggage and identify source
- Contact and report the event immediately to the supervisor/line manager and emergency services, if deemed necessary, who will then assume responsibility to initiate the local response plan.
- Coordinate the response in conjunction with Dangerous Goods Regulations (DGR) experts or emergency services.
- Identify and prevent from transport any other cargo, baggage or transport devices that have become contaminated by the leakage of dangerous goods.

### Security Incident

- Assess threat and follow the appropriate procedures
- Evacuate all persons if required
- Aircraft/Equipment to be positioned as directed.

### General Items to Consider

- Electrical devices, portable electronic devices (PEDs), camera including flashes must not be used.
- Restrict all vehicle movement
- Secure the area and comply with the emergency services directions.

- Control potential ignition sources.

### Aircraft evacuation without flight crew and passengers on board

The crew on board must hand over the aircraft to the new crew or maintenance personnel. In the absence of maintenance personnel or crew, the aircraft's external doors must be sealed to prevent unauthorized access. When there is no crew on board, and catering and/or cleaning staff are present, the responsibility for evacuating the aircraft in case of an emergency belong to the maintenance personnel.

- Roles and responsibilities for the evacuation belong to maintenance personnel.
- Procedures and different methods of evacuation from the aircraft (e.g., mobile stairs, PBB).

#### Note:

Escape slides are not intended as the primary means of exit. Means of communicating the evacuation (e.g., radios, audible warnings).

### Recognizing an Emergency

Timely recognition of an emergency is critical to initiating a safe and effective evacuation. Maintenance personnel must remain alert to signs of abnormal conditions, including unusual noises, smoke, burning smells, or visible flames. Leaks detected during bleed air, fuel, or hydraulic system operations, as well as electrical anomalies such as sparks or overheating following power-up, must be treated as potential emergencies. Sudden hazards occurring during APU or engine ground runs also require immediate attention.

#### Emergency Notification

In the event of an emergency, immediate and clear communication is essential to ensure the safety of all personnel. Maintenance personnel must first begin the evacuation process by shouting "EVACUATION/TAHLİYE" three times, alerting those on board and nearby. Then, if conditions permit, they may relay information such as "FIRE," "SMOKE," etc., regarding the nature of the incident. The airport control tower must be notified via VHF radio without delay. In hangar environments, the emergency alarm system should be activated if available.

#### Aircraft Evacuation

In the event of an emergency requiring evacuation, maintenance personnel must act quickly and follow the appropriate exit procedures based on their location and available access points.

- A. Via Passenger Doors (1L/1R, 2L/2R):** Doors can be opened manually from either inside or outside the aircraft. If stairs or maintenance platforms are available, slides should not be deployed. However, if no external access equipment is present, slides must be deployed to facilitate evacuation. Once outside, personnel should move at least 50 meters away from the aircraft. If there is a fire, smoke, or any obstacle outside, direct the personnel to an available exit.
- B. Via Overwing Exits:** If the main cabin doors are inaccessible, overwing exits may be used. These exits must be opened manually, and personnel should walk out holding the escape rope and slide down the wing to evacuate.
- C. Via Cockpit Window:** If no other exit is accessible, the cockpit side window may be opened and used as an emergency exit route. The flight compartment escape rope may be used to descend safely.

### Securing the Aircraft

If time and safety conditions allow, maintenance personnel should take steps to secure the aircraft following an evacuation to prevent further hazards. This includes shutting down the APU and engines, disconnecting external power sources, switching off fuel pumps and the aircraft battery, and verifying that wheel chocks are properly positioned. If a fire is present and conditions are safe, personnel may use a fire extinguisher to suppress the flames.

**Reporting**

Once the emergency situation is under control and all personnel are safe, it is essential to initiate the reporting process. Maintenance personnel must immediately inform the Maintenance Control Center (MCC) and the Shift Supervisor about the incident. The Incident/Hazard Report must be completed through SERA in accordance with internal reporting procedures.

**7.4. ACCIDENTS / INCIDENTS**

Please refer to Corendon Airlines Emergency Response Plan for the roles and responsibilities in cases of accidents / incidents.

**7.5. RAMP INCIDENT/ACCIDENT REPORT**

In the event of an incident or accident, the work must stop, the scene must be frozen and isolated and the initial report/event shall immediately be reported to Corendon Airlines Ground Operation Department via E-mail.

Then, Ground operation supervisor provides the initial report/event to the SMS department by submitting it via SERA reporting module in 24 hours and to SHGM by the SMS within 72 hours.

The handling company shall submit the current edition of IATA Ground Incident/Accident/Damage Report form (Please see the current edition of IATA AHM 650 for sample form) to the Corendon Airlines Ground Operation department and local authorities as required.

Ground Operation supervisor has to retain the records of the accidents/incidents on SERA system. SERA should be used for all events which causes damage, (aircraft, equipment, facility) occurring during ground operations. Timely completion of the report will ensure that the facts and circumstances of the occurrence are accurately recorded. The report should be submitted to all relevant parties as soon as possible after the occurrence.

The incident/accident report should also be submitted to IATA Incident Data Exchange (IDX) in accordance with the IATA ground damage reporting structure via SMS department as defined in Safety Management System Manual.

**7.6. DEATH ON BOARD**

a. In the event of a death during flight, the Captain shall notify the Handling Agent at the destination and indicate the following details:

- i. **Full name of the deceased, nationality, date of birth, home address, airport of embarkation and destination**
- ii. Circumstantial details of death i.e. exact time, altitude at time of death, medical assistance given if any, any circumstances in flight which may be important in connection with the death and whether the deceased was accompanied or not.

b. The Handling Agent shall immediately forward these details to CORENDON AIRLINES SITA Addresses (AYTOP7H, AYTDC7H) by QU or QX SITA message.

c. In addition, The Handling Agent shall inform the following, without undue delay:

- i. The Local Police, Passport Control and Airport Authorities
- ii. The Airport Doctor

d. A detailed station report shall be compiled and sent as soon as possible to the CORENDON AIRLINES Commercial Department in Antalya with a copy to the Operations Manager, containing the above mentioned information and in addition, the following:

- i. Sex of deceased
- ii. Age
- iii. Cause of death if known
- iv. Route of the flight
- v. Time from embarkation until death occurred

e. The Police shall give information to relatives of the deceased only.

**7.7. CHILD BIRTH DURING THE FLIGHT**

- a. In the event of child being born during a flight, the Handling Agent should obtain from the crew the following information:
- i. Date, time, place of birth, latitude and longitude
  - ii. Sex of child
  - iii. Full name of Parents
  - iv. Nationality of Parents
  - v. Home address
  - vi. Parent's profession
  - vii. Name and address of Captain and two other crew members
- b. This report must be signed by the Captain and forwarded to the CORENDON AIRLINES Ground Operations Department and duplicates must be sent by QU SITA to the CORENDON AIRLINES SITA Addresses.
- c. Notification will be given by the authorized Handling Company to the Airport Medical Unit, Passport Control and the Police.

**7.8. SAFETY MANAGEMENT SYSTEM (SMS)****7.8.1. Responsibilities**

Corendon Airlines management is firmly committed to providing and maintaining a safe and healthful working environment. To accomplish this all individuals will be held accountable for their role in the SMS.

All management personnel and non-management personnel are responsible for working safely and maintaining a safe work environment.

Personnel are required to conduct themselves in a manner that is consistent with the company safety rules and policies. All personnel are also responsible for safety performance of the SMS.

As Ground Operations Department, all responsibilities of management personnel and non-management personnel are defined in Safety Management System Manual.

All Safety Management System activities within Ground Operations shall be carried out in accordance with the Corendon Airlines Safety Policy, which defines the company's commitment to safety, management responsibilities, continuous improvement, and the expectation that all personnel actively support a proactive safety culture. The Safety Policy is published in the Safety Management System Manual and is applicable to all Ground Operations personnel.

**7.8.1.1 Chief Officer and Managers:**

Chief Operating Officer and Department Managers are responsible for working safely and maintaining a safe work environment. In order to fulfill this requirement, each manager must, but the responsibilities are not limited to:

- i. Review applicable safety laws, regulations and company procedures,
- ii. Fulfill the role of Operations Department Liaison as defined in the Emergency Response Plan (ERP), ensuring effective coordination between departments and other stakeholders during emergency activations. Promote and implement the safety policy in his/her department,
- iii. Ensure the SMS requirements are implemented in his/her department,
- iv. Identify hazards and evaluate, prioritize and process for risk assessment in their area,
- v. Regularly monitor and review their area of responsibility for hazards,

- vi. Encourage personnel to be familiar with the safety aspects of operational field where they work,
- vii. Take preventive actions and mitigations to avoid unsafe work conditions,
- viii. Monitor own SPIs with target and alarm levels concurrently and take the necessary actions and report to the SMS Department.
- ix. Encourage all personnel to report safety related events freely.
- x. Held department safety meetings to review the safety issues with participation of all related staff and record SERA Meeting Module.

Each manager is to inform SRB in the SRB meetings about at least the items given in related chapter of Safety Management System Manual.

#### **7.8.1.2 Safety Action Group (SAG)**

It is the responsibility of department managers to control and coordinate the activities of the SAG members and to ensure the participation of their members and to participate in the meetings with non-management person.

The SAG is tactical-level committee, chaired by the representative of SMS Department. The SAG provides the platform to collect and discuss the safety related information from the representative of all participant departments which are listed in related chapter of Safety Management System Manual.

The Safety Action Group Members have the responsibilities but they are not limited to:

- i. Monitor operational safety in the Corendon Airlines and Corendon ATO,
- ii. Resolve identified risks,
- iii. Assess the impact of operational changes on safety,
- iv. Ensure that safety actions are implemented within agreed timescales,
- v. Oversee operational safety performance within the functional areas of the organization and ensures that appropriate safety risk management activities are carried out with staff involvement as necessary to build up safety awareness,
- vi. Coordinate the resolution of mitigation strategies for the identified consequences of hazards and ensures that satisfactory arrangements exist for safety data capture and employee feedback,
- vii. Assess the safety impact related to the introduction of operational changes or new technologies,
- viii. Coordinate the implementation of corrective action plans and ensures that corrective action is taken in a timely manner,
- ix. Review the effectiveness of previous safety recommendations; and oversees safety promotion activities as necessary to increase employee awareness of safety issues and to ensure that they are provided appropriate opportunities to participate in safety management activities,
- x. Review the Safety Performance Indicators (SPI) which are detailed by own departments. The information will be given which is regarding to the performed corrective action for exceeding of the alarm level by department and recorded in meeting records

#### **7.8.1.3 All other Ground Operation Personnel**

All other Ground Operation personnel are required to conduct themselves in a manner that is consistent with the company safety rules and policies. To fulfill this requirement, each individual must:

- Review applicable safety laws, regulations and company procedures,
- Identify hazards and disclose safety reports in case of any unsafe events,
- Be familiar with the safety aspects of operational field where they work,

- Take corrective actions to avoid unsafe work conditions,
- Act in the safest manner practicable
- Fulfil the role of Go Team Ground Operation Liaison as defined in the Emergency Response Plan (ERP)

Please see Safety Management System Manual for more information.

## 7.8.2. Safety Risk Management

This process consists of 4 sub-processes (As seen below) triggering each other. These processes are followed each other in a logical sequence, hasty act to skip some of them, may result in erroneous results.



A hazard is a condition or an object with the potential to cause death, injuries to personnel, damage to equipment or structures, loss of material, or reduction of the ability to perform a prescribed function. As understood from the definition scope of hazards is extensive. This point makes it a versatile and multi participation thinking required. In other words, it confirms the need of participation of all staff once more.

The main objective of this cycle is to act in a safe band and when a tendency to get out of band, go back to the band with the measures taken. Here continuity is of paramount importance.

The purpose of SRM Process is not to set to zero the risk. The goal; To reduce possible damaging that may occur to acceptable level and maintain it at that level.

- Ground Operation Department gathers information from various sources for Hazard Identification:

- SERA Reports,
- SACA, SAFA reports,
- Cabin Flight Reports,
- Handling Operational Message (MVT)
- Consequences of Product Audits, System Audit etc.
- SAG, SRB meeting,
- Department safety and operational meeting
- Accident/Incident Investigations
- Passenger Complaints
- Publications issued by relevant authorities

Safety Risk Management of the department is conducting at SERA module under the Risk Management section

All defined/possible Risks, Hazards, SPIs, safety report cases and mitigations etc. shall be reviewed by Ground Operations SAG members at least once a year during the Department Safety Meetings and recorded in SERA under Meeting section, all defined risks, residuals and effectiveness of Risk Management should be considered and analyzed by Chief Operations Officer and Compliance Monitoring Supervisor

after the revisal meetings. Reassessment of the risks shall be recorded and logged in SERA under Risk Management module and the risks must be reviewed at least once a year.

- Hazard Identification Methodologies:

Hazard identification shall be based on a combination of reactive, proactive and predictive methods of safety data collection. The three methodologies for identifying hazards are:

METHOD	REACTIVE	PROACTIVE	PREDICTIVE
<b>MEANS</b>	<ul style="list-style-type: none"> <li>➤ Occurrence reports (accidents, serious incidents, incident)</li> <li>➤ Findings (audit/inspection/review)</li> </ul>	<ul style="list-style-type: none"> <li>➤ Hazards reports</li> <li>➤ Media follow-up</li> <li>➤ Airport assessment</li> <li>➤ Similar Airline Operation</li> <li>➤ Surveys (safety, fatigue, etc.)</li> <li>➤ Audits/inspections/reviews</li> <li>➤ Brain storming</li> <li>➤ Safety Meetings (SRB, SAG, ERP, etc.)</li> <li>➤ MoC</li> </ul>	<ul style="list-style-type: none"> <li>➤ coreSERA</li> <li>➤ SPIs</li> <li>➤ ORP</li> <li>➤ Surveys</li> </ul>

Please see Safety Management System Manual for more information.

### 7.8.3. Reporting and Investigation

Corendon Airlines has a reporting system with following methods that encourages and facilitates the reporting of events hazards and/or concerns resulting from or associated with human performance in ground handling operations.

- Mandatory Reporting,
- Voluntary Reporting,
  - Confidential Reporting
  - Non-Confidential Reporting

All unsafe situations, events, incidents and accidents shall be reported to SMS department via using SERA system. All Ground Operations Department Members are free to report all kind of safety related issues via this way.

The submitted report is evaluated by the SMS Department. According to topic, the report is assigned to the relevant department/departments' investigator for investigation.

Each reporter can follow-up his/her report/s in "Review Reports" tab in "Reporting" section of SERA. It gives opportunity to examine what action taken against each report in case of investigate any report by Ground Operation Department:

Compliance Monitoring Supervisor is responsible to investigate all reports and inform Chief Operating Officer about the results. All Ground Operations related reports shall be investigated and finalized as soon as possible.

Reports received should be considered as an opportunity by the relevant departments to identify hazards or review predefined hazards. In order to do this, the relevant department has to link the report received with the previously identified relevant hazard. If a new hazard will be identified based on the report received, the report must necessarily be linked to the relevant hazard.

The increase in the number of reports on the same subject must be taken into consideration by the relevant department/s in terms of hazard identification. Related hazard/s shall be reviewed by relevant department and risk assessment shall be revised if necessary.

Corendon Airlines operational safety reporting system:

- Encourages and facilitates ground handling operations personnel to submit reports that identify safety hazards, expose safety deficiencies and raise safety concerns;
- Requires reporting of events that result in aircraft ground damage;

Includes analysis and ground handling operations management action to address operational deficiencies, hazards, incidents and concerns identified through the reporting system.

Please see Safety Management System Manual for more information.

#### 7.8.4. Management of Change (MoC)

MOC is considered a proactive hazard identification activity in the SMS Change may affect the appropriateness or effectiveness of existing safety risk mitigation strategies. In addition, new hazards and related safety risk may be inadvertently introduced into an operation whenever change occurs.

In accordance of the Typical MOC Areas which is defined in related chapter of Safety Management System Manual, The Management of Change process is assessed and saved in SERA System.

Please see Safety Management System Manual for more information.

#### 7.8.5. SERA Aerodromes Module

Ground Operations Risks and Supplier Contacts should be stated in Aerodromes Module of SERA Compliance Monitoring Supervisor and other GOP SAG members are responsible to follow and input all the information to the Aerodromes Module according to CORENDON AERODROME ANALYSIS PROCESS. Aerodromes must be reviewed twice a year, prior to the summer season and prior to the winter season.

Please see Safety Management System Manual for more information.

#### 7.8.6. Safety Bulletins

The publications issued by relevant authorities such as National and International Civil Aviation Authorities, EASA etc. are analyzed for possible hazard identification and preventive actions. When required, it is published to the relevant parties.

Internal safety alerts and safety bulletins are distributed in case of any safety related issue.

Internal alerts can be published via SERA Initiatives section.

The external Bulletins can be published as Handling Instruction Bulletin form via e-mail regarding new aircraft registered types, operational issues etc.

Please see Safety Management System Manual for more information.

#### 7.8.7. Safety Performance Indicators (SPI's)

In coordination with the SMS and Ground Operations Departments all related SPI's shall be defined in SERA SPI table. SPI targets, monitoring the safety performance, validating the effectiveness of risk controls and alarm limits should be followed within the specified time limitation by Ground Operations Department.

In case of exceeding the limits, any SPI is mitigated such performing audits, planning additional trainings, distributing the safety bulletins etc. and the related actions are added to involved SPI in SERA module.

Safety Performance Indicators shall be monitored and evaluated on a monthly basis. Trend analyses shall be conducted on a quarterly basis to assess performance against targets and identify emerging safety risks.

Please see Safety Management System Manual for more information.

#### **7.8.8. Meetings**

The Members of SAG and SRB for Ground Operation Departments are being attended the meetings regularly in order to discuss all safety issues. Meeting dates are announced to all members of SAG and SRB by SMS Department.

After the meetings are completed, The Ground Operation Personnel are informed about the safety meetings by SAG and SRB Members. And this notification is saved in SERA System.

Please see Safety Management System Manual for more information.

Also Ground operation department meets quarterly (at least 4 times per year) to share all information related to safety issues (audits reports, mails, security/safety threats etc.)

#### **7.8.9. Trainings**

All personnel must understand Corendon Airlines' safety philosophy, policies, procedures and practices. They must also assume their roles and responsibilities within safety framework. SMS training is vital to ensure that and also establishing a mature safety culture will be achieved via safety training to appropriate staff, regardless of their level in the organization.

The initial and recurrent training are being completed in accordance with SMS Training Syllabus.

Please see Safety Management System Manual for more information.

### **7.9. EMERGENCY RESPONSE PLAN (ERP)**

#### **7.9.1. Responsibilities**

##### **7.9.1.1 Ground Operation Liaison**

Chief Operating Officer serves as Ground Operations Liaison in Crisis Management Centre. Principal tasks are;

- to call relevant staff for duty
- To make necessary protocols with handling agents about extra staffing in crisis conditions. These staff act on behalf of Corendon Airlines in the beginning of crisis in their own airports.
- To allocate Family and Friends Reception Centre in the events occurring in Antalya, direct relatives of passengers to these centers, response for passengers' need (food and beverages, communication, etc.) or pass them to Crisis Management Centre.
- To ensure the clear flow of relevant information to and from all stations and keep the Crisis Management Centre informed of the situation in the different stations.
- To instruct the stations directly involved in the emergency to lock passenger information in the reservations systems of both the operating and marketing carriers, CAI call centers and, in the case of code sharing, to secure copies of appropriate passenger manifests.
- To send all collected document SMS Liaison which is detailed in Company Crisis Document List.
- To prepare the requested documents in Company Crisis Document List and send to Emergency Response Manager. In absence of Emergency Response Manager or in case of delay, he/she is to

send this form to e-mail address (uodops@shgm.gov.tr) of Turkish DGCA no later than one (1) hour.

- To add the latest version of ERP Manual into the company web library for the third parties.
- To attend the ERP training when required.

### 7.9.1.2 Go Team Ground Operation Liaison

Dedicated Ground Ops Officer serves as Ground Ops Liaison in Go Team. Principal tasks are;

- to be present in the meeting area as soon as possible ready to travel
- to arrange facility for Go Team
- to respond emerging needs of Go Team via service providers in or vicinity of incident site,
- to support all operation carried out in the incident site
- to deliver the check list and action logs prepared during the mission to the SMS Liaison.

### 7.9.1.3 Special Assistance Team Members

Corendon Special Assistance Team Members are selected from Corendon Airlines staff that may be able to provide effective assistance with their knowledge and/or experience.

The following should be considered when selecting Corendon Special Assistance Team Members;

- language skills,
- social and interactive skills,
- ability to communicate in a calm and sympathetic nature,
- previous experience and/or department of graduation e.g. psychology graduates would be a good choice,
- Understanding of the company culture.

Corendon Special Assistance Team Members must;

- Be willing to be a part of the Corendon Special Assistance Team and to be actively involved with assigned/outlined duties when necessary.
- Be present at Special Assistance Desks established at Family Assistance Centre(s) to greet family, NOKs direct them to family briefing room(s) and/or reception areas.
- Help and provide guidance to NOKs of passengers or of crew members filling in required forms. These forms shall be safeguarded until the contracted International Emergency Service Provider arrives at the crisis center.
- Monitor the circumstances at Special Assistance Desks, reception areas and family briefing rooms and notify the Corendon Special Assistance Liaison if improvements of locations are necessary.
- Provide the Corendon Special Assistance Liaison with factual information and updates at regular intervals regarding the latest developments and circumstances.
- If required, ask the Corendon Special Assistance Liaison for spending authority.
- Retain any sort of correspondence papers and invoices for every action taken.
- Ask to be relieved from duties if coping with conditions/circumstances become too stressed, exhausting or any other case that makes it difficult to cope with or handle assigned duties.
- If required, a thorough shift change briefing shall be performed when handing over duties to other Family Assistance Centre members.
- Coordinate briefing with the contracted International Emergency Service Provider when they arrive.

Please see Emergency Response Plan for the remaining department's responsibilities.

All these documents shall be reviewed by Ground Operations Staff

**7.9.2 Crisis Document List**

Crisis Document Lists are existed under SMS Team folder and following regularly

**7.10 REDUCTION OF CABIN CREW DURING GROUND OPERATIONS AND IN UNFORESEEN CIRCUMSTANCES**

Subject to the conditions specified below, number of minimum cabin crew member may be reduced:

- i. during normal ground operations not involving refueling/defueling when the aircraft is at its parking station; or
- ii. In unforeseen circumstances if the number of passengers carried on the flight is reduced. In this case a report shall be submitted to the competent authority within 72 hours after completion of the flight.

Unforeseen circumstances in this context refer to incapacitation and unavailability of a senior cabin crew member or a cabin crew member as follows:

- a) 'Incapacitation' means a sudden degradation of medical fitness that occurs during flight duty period either in-flight or during a flight transit of the same flight duty period away from company base and that precludes the senior cabin crew member or cabin crew member from performing his/her duties. Incapacitation prior to dispatch of the aircraft from a base of the company does not substantiate a reduction of the cabin crew complement below the minimum required.
- b) 'Unavailability' means circumstances at a stopover (layover) destination that preclude the senior cabin crew member or cabin crew member from reporting for the flight duty period, such as traffic jams that prevent the senior cabin crew member or cabin crew member from presenting himself/herself at the crew pick-up point in time, difficulties with local authorities, health problems, death, etc. Unavailability does not refer to insufficient number or absence of cabin crew members on standby, or absence from work due to pregnancy, maternity/paternity leave, parental leave, medical leave, sick leave, or any other absence from work.

**Incapacitation in A/C on Ground at Home Base**

When a cabin crew member becomes incapacitated on ground at their home base, crew shall provide first aid and if necessary the PIC shall call for the airport paramedics and inform OCC and/or Crew Planning. The incapacitated crew member/SCCM shall be offloaded and replaced by a standby cabin crew member/SCCM.

**Incapacitation during aircraft transits where no crew are available**

When a cabin crew member becomes incapacitated on ground in the aircraft during a transit stop, crew shall provide first aid and if necessary, the flight crew shall call for the airport paramedics and inform OCC and/or Crew Planning. A senior cabin crew member, who becomes incapacitated during a flight or series of flights, or unavailable at a stopover (layover) point, should be replaced without undue delay by another senior cabin crew member qualified on the concerned aircraft type/variant. If there is no other senior cabin crew member, the most appropriately qualified cabin crew member should be assigned to act as senior cabin crew member in order to reach a base of the operator. If during the series of flight, the aircraft transits via a base of the operator, the assigned cabin crew member acting as senior cabin crew member should be replaced by another senior cabin crew member.

Conditions for the Reduction of Cabin Crew Members:

- At least one cabin crew member is required for every 50, or fraction of 50, passengers present on the same deck of the aircraft.
- In the case of normal ground operations with aircraft requiring more than one cabin crew member, the number determined below shall be increased to include one cabin crew member per pair of floor level emergency exits.

Reduced Number of Cabin Crew Members:

Number of Occupied Seats	Min. Cabin Crew
151 - 189	4
101 - 150	3
1 - 100	2

## 8. DANGEROUS GOODS AND WEAPONS

Dangerous Goods (will be referred as the DG hereinafter), as described and listed in the IATA Dangerous Goods Regulations, are the substances which are capable of causing harm to the passenger, to the crew, to the aircraft and to the cargo on the aircraft, as well as to the environment, due to chemical and physical characteristics they have. Therefore; they must never be accepted to carriage unless they are consistent to DGR and contemporary publications.

The basics of transportation of dangerous goods are the book ICAO published "Technical Instructions for the Safe Transport of Dangerous Goods by Air". The creation of this book is based on the UN Subcommittee of Experts on the Transport of Dangerous Goods (SCoETDG) and International Atomic Energy Agency (IAEA)'s studies and procedures.

Current edition of the IATA Dangerous Goods Regulations (DGR), the ICAO Technical Instructions for the Safe Transport of Dangerous Goods by Air (Technical Instructions) or equivalent documentation shall be accessible at each location where cargo, passenger check in and boarding operations are conducted. Also shipments containing Dangerous Goods must be handled according to these reference documents, Corendon Airlines GOM and OM-Part A

Corendon Airlines is approved by Turkish DGCA for DG carriage.

### 8.1 THE TRANSPORT OF DANGEROUS GOODS

#### References:

- Annex 18 to the Chicago Convention as last amended.
- Technical Instructions for the Safe Transport of Dangerous Goods by Air (ICAO Doc 9284-AN/905).
- IATA Dangerous Goods Regulations.
- Emergency Response Guidance for Aircraft incidents and Accidents involving Dangerous Goods (Doc 9481-AN928)

#### 8.1.1 Terminology

**Acceptance Check List:** A document used to assist in carrying out a check on the external appearance of packages of dangerous goods and their associated documents to determine that all appropriate requirements have been met.

**Approval:** An authorization referred to in the Technical Instructions and issued by an Authority, for the transport of dangerous goods which are normally forbidden for transport or for other reasons, as specified in the Technical Instructions.

**Consignee:** Any person, organization or government which is entitled to take delivery of a consignment.

**Dangerous Goods (DG):** Articles or substances which are capable of posing a risk to health, safety, property or the environment and which are shown in the list of dangerous goods in the Technical Instructions or which are classified according to those Instructions.

**DG Accident:** An occurrence associated with and related to the transport of DG which results in fatal or serious injury to a person or major property damage.

**Dangerous Goods Shippers Declaration:** The document where the shipper declares that the dangerous goods shipment is made according to the valid rules of IATA and DGR.

**DG Incident:** An occurrence, other than a DG accident, associated with and related to the transport of DG, not necessarily occurring on board an aircraft, which results in injury to a person, property damage, fire, breakage, spillage, leakage of fluid or radiation or other evidence that the integrity of the packaging has not been maintained. Any occurrence relating to the transport of DG which seriously jeopardizes the aircraft or its occupants is also deemed to constitute a DG incident.

**DG Transport Document:** A document which is specified by the Technical Instructions. It is completed by the person who offers DG for air transport and contains information about those dangerous goods.

**Exemption:** For the purposes only of compliance with this Chapter, an authorization referred to in the Technical Instructions and issued by all the authorities concerned, providing relief from the requirements of the Technical Instructions.

**Freight Container:** A freight container is an article of transport equipment for radioactive materials, designed to facilitate the transport of such materials, either packaged or unpackaged, by one or more modes of transport. (Note: see unit load device where the DG are not radioactive materials.)

**Handling Agent:** An agency which performs on behalf of the operator some or all of the latter's functions including receiving, loading, unloading, transferring or other processing of passengers or cargo.

**Over pack:** An enclosure used by a single shipper to contain one or more packages and to form one handling unit for convenience of handling and stowage. (Note: a unit load device is not included in this definition.)

**Package:** The complete product of the packing operation consisting of the packaging and its contents prepared for transport.

**Packaging:** Receptacles and any other components or materials necessary for the receptacle to perform its containment function.

**Serious Injury:** An injury, which is sustained by a person in an accident and which:

- Requires hospitalization for more than 48 hours, commencing within seven days from the date the injury was received; or
- Results in a fracture of any bone (except simple fractures of fingers, toes or nose); or
- Involves lacerations which cause severe hemorrhage, nerve, muscle or tendon damage; or
- Involves injury to any internal organ; or
- Involves second or third degree burns, or any burns affecting more than 5 % of the body surface; or
- Involves verified exposure to infectious substances or injurious radiation.

**Shipper:** The person preparing shipment for flight in the name of the unit requesting the shipment of goods.

**Radioactive Substance:** Radioactive substances are substances that emit momentarily or continuously radiation in various types that may cause harm to health or other creatures.

**Transport Index:** The Transport Index indicates the distance of the parcels containing radioactive substance from the human beings and other cargoes during loading and storage.

**Technical Instructions:** The latest effective edition of the Technical Instructions for the Safe Transport of Dangerous Goods by Air, including the Supplement and any addenda, approved and published by decision of the Council of the International Civil Aviation Organization (ICAO Doc 9284-AN/905).

**Unit Load Device:** Any type of aircraft container, aircraft pallet with a net, or aircraft pallet with a net over an igloo. (Note: an over pack is not included in this definition; for a container containing radioactive materials see the definition for freight container.)

### 8.1.2 General Guidance on the Transport of DG

DG are articles or substances which are capable of posing a risk to health, safety, property or the environment and which are shown in the list of DG in IATA DGR or which are classified according to those regulations. Terms which have special meaning within those regulations, are defined in IATA DGR App. A.

Nevertheless, there are DG required to be on board an aircraft for operating reason under responsibility of Corendon Airlines. Those are for:

- the airworthiness of the aircraft,
- the safe operation of the aircraft,
- The health of passengers and crew.

Such dangerous goods include but are not limited to:

- Batteries,
- Fire extinguishers,
- First aid kits,
- Insecticides / Air fresheners,
- Life saving devices,
- Portable oxygen supply.

### Categories of DG:

Dangerous goods are divided into three categories:

- goods which are generally allowed to be transported by aircraft considering the respective IATA-instructions for packing and transportation,
- goods for which exceptional regulations exist,
- Goods which are excluded from air transport.

DG are further divided into nine hazard classes according to IATA DGR Chapter 3.0.2. For transport they must be marked by sticker corresponding to the respective directions laid down in the IATA DGR.

A four-digit number (UN Number) assigned by the United Committee of Experts on the Transport of DG serves to identify a Substance or a particular group of substances. Substances and articles of the same danger are combined in classes (UN classes of risk). Divisions (three letter code) distinguish the cause of the effect.

### 8.1.3 Corendon Airlines Policy on the Transport of DG

Corendon Airlines actual DG operations can only be performed when Turkish DGCA add related approval to our operations specifications.

Corendon Airlines is responsible for the acceptance, inspection, storage, loading and provision of information. Corendon Airlines not only applies the regulations effective in DGR; but also publishes national and internationally updated laws, ICAO Annexes, EU rules, general DGR rules, all publications, directives and other manuals about the subject, the company laws and all other regulations.

None of the dangerous goods or substances will be accepted for carriage unless determined in the IATA DGR, EU and other national / international rules. In case of any doubt regarding the content of the goods asked to be carried, the transportation must be suspended until the subject is totally clarified.

At stations where the shipments to be carried on Corendon Airlines aircrafts are accepted by a contracted handling agent. Corendon Airlines must ensure that the handling agent has the current IATA DGR book and the agent staff is trained and has the valid certification.

Therefore, responsible personnel will accept or reject the transport of DG with the light of the information in this chapter. Additionally, for future concerns, some detail information is given in this chapter.

To get the approval for the transport of DG, the following requirements must be complied with:

- All relevant documents for ground handling, aircraft handling, and training contain information and instructions on DG.
- Procedures must be at hand to ensure the safe handling and transport of DG.
- Adequate training must have been given to all staff who is either engaged in the transport of DG or who may come into contact with them during their duties.

At below also there will be some specific regulations for DG carriage on Corendon Airlines Flights and Aircrafts

- Dangerous Goods in "Limited Quantities" ("Y" Packing Instruction) will not be accepted for carriage. Exceptions: Consumer commodity (ID 8000) will be accepted (see Subsection 2.7 and all "Y" Packing Instructions).
- Dangerous Goods in consolidations will not be accepted for carriage, except for the following shipments;
  - Consolidations containing UN1845, Carbon dioxide, solid (Dry Ice) when used as a refrigerant; or
  - Consolidations with only one house Air waybill; or
  - Consolidations with more than one house Air waybill, which have the same shipper and different consignees.
- Dangerous goods will not be accepted in air mail.
- UN 1845 Carbon dioxide, solid (Dry Ice) is restricted to a maximum of 200 kg per aircraft on all Corendon Airlines aircraft types. (combined for FWD, AFT holds)
- Biological substance, Category B, UN3373 will not be accepted for transport.
- Fissile Material will not be accepted.
- The shipper must provide a 24-hour emergency telephone number of a person/agency who is knowledgeable of the hazards, characteristics and actions to be taken in the case of an accident or incident concerning each of the dangerous goods being transported. This telephone number, including the country and area code, preceded by the words "Emergency Contact" or "24-hour number", must be inserted on the Shipper's Declaration for Dangerous Goods, preferably in the "Handling Information" box.
- A 24-hour emergency telephone number is not required for shipments that do not require a Shipper's Declaration for Dangerous Goods.
- Corendon Airlines do not accept radioactive materials.
- Lithium ion and lithium metal cells and batteries (UN3480, UN3090) will not be accepted for carriage as cargo.
- This prohibition does not apply to lithium batteries (rechargeable and non-rechargeable) covered by the Provisions for Dangerous Goods Carried by Passengers or Crew (see IATA DGR Table 2.3.A).

#### **8.1.4 Operator's Responsibilities**

Corendon Airlines is responsible for the acceptance, storage, loading and inspection of the goods, provision of information, emergency response information, retention of records and training.

National instructions may require to get licenses of permission and authorization for air transportation and to renew those documents periodically. CAI is responsible for fulfilling both.

In addition, CAI must place informative boards and warning charts about dangerous and hidden dangerous goods for both shippers and passengers at cargo acceptance, passenger check-in, ticket sales, boarding and baggage claim areas. CAI must ensure that;

- Dangerous goods are only accepted by persons having a valid dangerous goods certificate.
- Once the authorized handling agents, accomplish the necessities indicated on IATA DGR and current publications.

- Dangerous goods are only accepted by the approval of CAI and if the approval of DGCA is stated in operations specifications.

In the carriage of dangerous goods, the operator must fulfill the necessities in the appropriate DGR sections on the below mentioned phases.

- a. Acceptance
- b. Storage
- c. Loading
- d. Control
- e. Provide necessary information
- f. Providing necessary information, including Emergency Response Information.
- g. Reporting.
- h. Training.

To be allowed to transport dangerous goods by air, Corendon Airlines shall:

- Obtain a transport of dangerous goods approval from the national airworthiness authorities.
- Ensure that handling personnel involved is thoroughly trained with dangerous goods handling.
- Ensure that handling personnel perform an external visual inspection to ensure that the contents of the dangerous goods packages are acceptable for the transport by air.
- Ensure that the physical handling requirements, as e.g. marking, of the dangerous goods - as required by the contents - are complied with.
- Ensure that all loading requirements and restrictions are complied with and communicated to the responsible personnel with the operation of the aircraft.
- Ensure that the presence of the dangerous goods is communicated properly to the flight crew as per the requirements via the NOTOC.

### 8.1.5 Limitations on the Transport of DG

The articles and substances or other goods declared as DG that are specifically identified by name or generally described in the Technical Instructions shall be forbidden for transport under any circumstances are not carried on any aircraft.

Corendon Airlines shall not carry articles and substances or other goods declared as DG that are identified in the Technical Instructions as being forbidden for transport in normal circumstances unless the following requirements of those Instructions have been met:

- a) The necessary exemptions have been granted by all the States concerned under the requirements of the Technical Instructions; or
- b) An approval has been granted by all the State(s) concerned on those occasions when the Technical Instructions indicate that only such approval is required.

### 8.1.6 Acceptance of DG

It is obligatory for the units dealing with cargo to have sufficient number of trained and certificated employees, about acceptance of dangerous goods in the extension of the contemporary rules. The concerned presidencies must provide necessary training for the staff according to their content of duties

All of the trainings concerning Dangerous Goods must be updated by refreshment courses before exceeding 2 years.

#### Booking:

Corendon Airlines does not accept dangerous goods for transportation without prior booking. At the time of booking, it must be checked whether the good is appropriate for carrying. The booking of the dangerous

goods must be confirmed until the final destination. Booking and confirmation are required for all DG shipments as defined in IATA DGR (Ref 1.3.2. and 9.1.2.)

Corendon Airlines Ground Operations Department:

Tel: +90 242 330 3336/1217 internal

Fax: +90 242 330 3307

Mail: [dgr@corendon-airlines.com](mailto:dgr@corendon-airlines.com) / SITA: AYT07H

### Acceptance

A dangerous substance booked previously must be together with the package and the documentation prepared in accordance with all rules in effect at the time of delivery to the carrier. Damaged, missing or leaking packages and/or with compromised integrity must not be accepted for transportation.

- Cargo staff accepting dangerous goods must have valid certificate of DG training.
- In Dangerous Goods acceptance, the cargo and the relevant documents must be delivered at once.
- The packages of Dangerous Goods that exhibit damage, missing, leaking or oozing must never be accepted.
- In acceptance of radioactive substances, the permission obtained from the Turkish Atomic Energy Institution must also be questioned by the personnel who accept the cargo. If the permission is lacking, the cargo must not be accepted.
- It must be checked by the cargo personnel having valid certificate whether the consignment meets the rules by using the Check List.
- If a shipment is refused for carriage, the name of the agent or shipper must be written on the related part and the date and the reason for refusing the shipment must be added in order to be referred in case of an objection. The original copies of the check list issued for the refused shipment must be locally retained for any act of amendment. If shipment is re-offered for transportation a new check list must be issued for it.
- The original of the Check List for the rejected consignment must be filed by the cargo acceptance units. The checklist should be retained for a minimum period of 1 year after the completion of the acceptance checklist
- If the consignment has been accepted after the check as per the Check List, the relevant fields of the Check List must be completed and signed. The description of the goods (consignment), the UN-ID information and the special handling code entered into the booking screen of the TACTIC System must be checked with the information given in the Shipper's Declaration, and the information in the system must be updated if necessary.
- The shipper must provide a 24-hour emergency telephone number of a person/agency who is knowledgeable of the hazards, characteristics and actions to be taken in case of an accident or incident concerning each of the dangerous goods being transported.
- Material Safety Data Sheet (MSDS) must be provided for dangerous goods except for dangerous goods in Class 7, vehicles, dangerous goods in apparatus or machinery and engines, ID 8000, magnetized material, carbon dioxide, solid (dry ice) and Division 6.2. The MSDS must be written in English. The MSDS must include the UN number, proper shipping name and other relevant transport information.
- Dangerous goods as defined in these Regulations will not be accepted in Air Mail (see 2.4).

### Acceptance of Bad and Pungent Smelling Cargos

The goods that create an effect so as to excessively disturb the surrounding and the officers in a way to prevent them from performing their tasks as a result of leaking during transportation must be carried in accordance with the DGR rules.

### Check List

Unless otherwise stated in the rules, 2 copies of 'dangerous goods check list' must be issued for all dangerous goods shipments during acceptance. The shipment must not be rejected before all items in the check list are answered. Even only one of the questions are replied as 'No', the shipment must be refused. One of the copies must be given to the shipper and the reason why the shipment is refused must be explained.

The check list must be in comply with the IATA DGR current edition and must be convenient to search for all necessities about documentation, packing, labeling, marking, etc.

A “checklist” is not required for dangerous goods in excepted quantities and radioactive material in excepted packages.

While accepting dangerous goods the employees who have valid certificates must check the shipment in accordance with a check list to verify that it is suitable to the rules. There are 2 different types of check lists; for radioactive and non-radioactive materials. The check list must be in double copies and arranged in English and the instructions at the beginning must have been obeyed to. In case it is a state or operator’s variation to prepare the check list in a different language, then it must be attached to the English version.

If a shipment is refused for carriage, the name of the agent or shipper must be written on the related part and the date and the reason for refusing the shipment must be added in order to be referred in case of an objection. The original copies of the check list issued for the refused shipment must be locally retained for any act of amendment. If the shipment is re-offered for transportation a new check list must be issued for it.

Beside all new editions of the DGR the check lists must be looked over to be updated and the previous editions must be destroyed as soon as new editions started to be used.

Dangerous Goods Acceptance Check List shall be retained for a minimum period of 1 year after the flight on which the dangerous goods were transported.

### **Storage**

The accepted Dangerous Good must be received into the warehouse and kept there safely until the preparations of the flight.

If the label on any package is missing, torn or became invisible at any stage of transportation after the acceptance, it must be replaced by the cargo personnel by referring to the documents.

If the shipper or the DGR has given special instructions regarding the Dangerous Goods, they must be strictly fulfilled. For example, if the shipper has required that the consignment must be carried at a given temperature throughout the transportation cycle, this temperature must be maintained also during the storage.

If there are special instructions given by the shipper or current IATA DGR rules they must be fulfilled. For example, in case of a special heat demand by shipper, it must be provided while storing and taking it to the aircraft.

### **Provision for DG Carried by Passengers or Crew:**

DG is not allowed to be carried in or as passengers or crew luggage except as otherwise provided in the table below.

It is allowed to take along those articles and substances which would otherwise be classified as DG and which are listed in parts below. Articles and substances carried as catering or cabin service supplies,

- Veterinary aid or humane killer for an animal,
- Safety matches and cigarette lighter in a pocket,
- Implanted cardiac pacemaker with radioactive material or radiopharmaceutical medicaments in the body of a passenger for medical treatment,
- Non-radioactive medicinal and cosmetic articles - including aerosols - but not more than two liters or two kilograms,
- Alcoholic beverages not exceeding 70% by volume when packed in receptacles of less than 5 liters.

The followings are those that may be carried only with authorization by Corendon Airlines:

- Gaseous oxygen or air in small cylinders for medical purpose,
- A self-inflatable life jacket with a small CO2 cylinder.

Also, Corendon Airlines shall alert passengers during check-in by visual materials or verbally related to certain items of DG are specifically prohibited in hold baggage, cabin baggage and on person.

**Corendon Airlines policy is to follow the provisions for Dangerous Goods carried by passengers or flight crew as specified in the IATA DGR Table 2.3.A**

**Please see Section 10 Forms**

### **8.1.7 Labeling and Marking of Dangerous Goods**

The labelling and packing rules and instructions for dangerous goods transportation specified in the IATA Dangerous Goods Regulations shall be applied.

Packages for dangerous goods have been divided among three packing groups, this separation is according to the degree of the danger the transported goods present:

- (a) Packing group I - Great danger
- (b) Packing group II - Medium danger
- (c) Packing group III - Minor danger

It is shipper's responsibility to label and mark the dangerous goods in accordance with the rules. Necessary labels are provided by the operator. Dangerous Goods and Handling labels and markings are used to divert the attention of the staff dealing with transportation.

During the process of transportation after acceptance, it is under responsibility of the related staff of the operator to renew the labels by the help of documentation check, if the label has fallen down, torn or has become invisible by any means. Corendon Airlines is obligated to provide dangerous goods labels when needed, at any station being operated.

Labels are of two types.

- (a) Hazard Labels

Which are required for most dangerous goods in all classes?

- (b) Handling Labels (in various rectangular shapes)

Which are required, either alone or in addition to hazard labels, for some dangerous goods

The following marking and information shall be included in the labeling;

**Proper Shipping Name:** Name of dangerous item as shown in the alphabetical list of the DGR

**UN/ID Number:** Four digit-number, assigned by the UN (UN-no) -or IATA (ID-no) Name and address of shipper

**Hazard Label:** Must comply with label specification (shape / size / color / symbol / class no.)

**Specification marking (if UN-specified packaging has been used):** Identifies the packaging for having been tested according to UN-guidelines

**Additional Markings for Explosives:** Net quantity and gross weight of the package

**Refrigerated Liquefied Gases:** "Keep upright"/"Do not drop-handle with care"

**Infectious Substances:** Name and phone number of a person responsible for the shipment

**Radioactive Materials:** Permissible gross weight of the package if this exceeds 50 kg.

**Dry Ice:** Net weight of dry ice within the package

**8.1.7.1 Classification of DG and Hazard Labels****CLASS 1 EXPLOSIVES**

Explosive articles and substances are assigned to one of six divisions and to one of thirteen compatibility groups. Not all compatibility groups are to be found in all divisions.

Most explosives, such as those classed within Divisions 1.1, 1.2, 1.3 (with a few exceptions), 1.4F, 1.5 and 1.6 are normally forbidden for carriage by air.

Divisions: 1.1 / 1.2 / 1.3 / 1.4 / 1.5 / 1.6

Compatibility Groups: A / B / C / D / E / F / G / H / J / K / L / N / S

(See IATA DGR, Compatibility Groups for Explosives 3.1.4, Table 3.1.A)

The explosives listed below are permitted for transportation on civil aircraft.

Cargo Aircraft Only (CAO) 1.3 C RCX Passenger and Cargo

1.4 S RXS

1.3 G RX Aircraft (PAX OK)

1.4 B RXB

1.4 C RXC

1.4 D RXD

1.4 E RXE

1.4 G RXG

**Class 1 Explosive Divisions**

<b>Name</b>	Explosive
<b>Class/Division</b>	Class 1 / Division 1.1
<b>Cargo IMP Code</b>	REX, RCX, RGX as applicable
<b>Label</b> Minimum Dimensions: 100x100 mm Symbol (exploding bomb): Black Background: Orange	
<b>Description</b>	Articles and substances having a mass explosion hazard.
<b>Note</b>	A mass explosion is one which affects almost the entire load virtually instantaneously.  Packages bearing this label are not normally permitted for air transport.

<b>Name</b>	Explosive
<b>Class/Division</b>	Class 1 / Division 1.2
<b>Cargo IMP Code</b>	REX, RCX, RGX as applicable
<b>Label</b> Minimum Dimensions: 100x100 mm Symbol (exploding bomb): Black Background: Orange	
<b>Description</b>	Articles and substances having a projection hazard but not a mass explosion hazard.
<b>Note</b>	Packages bearing this label are not normally permitted for air transport.

<b>Name</b>	Explosive
<b>Class/Division</b>	Class 1 / Division 1.3
<b>Cargo IMP Code</b>	REX, RCX, RGX as applicable
<b>Label</b>  Minimum Dimensions: 100x100 mm Symbol (exploding bomb): Black Background: Orange	
<b>Description</b>	Articles and substances having a fire hazard, and either a minor blast hazard or a minor projection hazard or both, but not a mass explosion hazard. This division comprises articles and substances that: - Give rise to considerable radiant heat, or - Burn one after another producing minor blast and/or projection effects.

<b>Name</b>	Explosive
<b>Class/Division</b>	Class 1 / Division 1.4
<b>Cargo IMP Code</b>	RXB, RXC, RXE, RXG, RXS, RXD as applicable
<b>Label</b>  Minimum Dimensions: 100x100 mm Symbol (division number): Black Background: Orange	  * Place for compatibility group
<b>Description</b>	Articles and substances that present no significant hazard. This division comprises articles and substances, which present only a small hazard in the event of ignition or initiation during transport. The effects are largely confined to the package and no projection of fragments of appreciable size or range is to be expected. An external fire must not cause virtually instantaneous explosion of almost the entire contents of the package.
<b>Note</b>	The numerals "1,4" printed on the label must be at least 30 mm in height and about 5 mm wide.

<b>Name</b>	Explosive
<b>Class/Division</b>	Class 1 / Division 1.5
<b>Cargo IMP Code</b>	REX
<b>Label</b>  Minimum Dimensions: 100x100 mm Symbol (division number): Black Background: Orange	 <p>* Place for compatibility group</p>
<b>Description</b>	Very insensitive substances having a mass explosion hazard. Which are so insensitive that there is very little probability of initiation or of transition from burning to detonation under normal conditions of transport.
<b>Note</b>	Packages bearing this label are not normally permitted for air transport.

<b>Name</b>	Explosive
<b>Class/Division</b>	Class 1 / Division 1.6
<b>Cargo IMP Code</b>	REX
<b>Label</b>  Minimum Dimensions: 100x100 mm Symbol (division number): Black Background: Orange	 <p>* Place for compatibility group</p>
<b>Description</b>	Extremely insensitive articles, which do not have a mass explosive hazard. This division comprises articles which contain only extremely insensitive detonating substances and which demonstrate a negligible probability of accidental initiation of propagation.
<b>Note</b>	Packages bearing this label are not normally permitted for air transport.

**CLASS 2 GASES**

A gas is a substance which:

At 50 °C (122 °F) has a vapor pressure greater than 300 kPa (3,0 bar, 43,5 lb/in<sup>2</sup>); or

Is completely gaseous at 20 °C (68 °F) at a standard pressure of 101,3 kPa (1.01 bar, 14,7 lb/in<sup>2</sup>).

This class comprises; compressed gases, liquefied gases, gases in solution, refrigerated liquefied gases, mixture of gases, mixtures of one or more gases with one or more vapors of substances of other classes, articles charged with a gas, tellurium hexafluoride, aerosols.

<b>Name</b>	Flammable Gas
<b>Class/Division</b>	Class 2 / Division 2.1
<b>Cargo IMP Code</b>	RFG
<b>Label</b> Minimum Dimensions: 100x100 mm Symbol (Flame): Black or White Background: Red	
<b>Description</b>	Any compressed gas which, when mixed with air in certain proportions, forms a flammable mixture. e.g. butane, hydrogen, hairspray, lighters
<b>Note</b>	This label may also be printed with symbol (flame), text, numbers and border line shown in black on red background

<b>Name</b>	Non-flammable, Non-toxic Gas
<b>Class/Division</b>	Class 2 / Division 2.2
<b>Cargo IMP Code</b>	RNG or RCL as applicable
<b>Label</b> Minimum Dimensions: 100x100 mm Symbol (Gas Cylinder): Black or White Background: Green	
<b>Description</b>	Non-flammable Gas, Non-toxic Gas e.g. Compressed air, fire extinguishers
<b>Note</b>	This label may also be printed with symbol (gas cylinder), text, numbers and border line shown in black on green background.

<b>Name</b>	Toxic Gas
<b>Class/Division</b>	Class 2 / Division 2.3
<b>Cargo IMP Code</b>	RPG
<b>Label</b>  Minimum Dimensions: 100x100 mm Symbol (Skull&Crossbones): Black Background: White	
<b>Description</b>	Toxic gas e.g. Chlorine, carbon monoxide
<b>Note</b>	Toxic Substances labels inscribed with the text "Toxic Gas" or "Poison Gas" are acceptable. Normally Forbidden on Passenger Aircraft

**CLASS 3 FLAMMABLE LIQUIDS**

This class has no sub-divisions.

It comprises liquids or mixtures of liquids or liquids containing solids in solution or in suspension (for example paints, varnishes, lacquers, etc., but not including substances otherwise classified on account of their dangerous characteristics), which give off a flammable vapor at temperatures of:

Not greater than 60.5 °C (141 °F), according to closed-cup test; or

Not greater than 65.6 °C (150 °F), according to open-cup test, normally referred to as the flash point.

Flash Point: Lowest temperature at which enough flammable vapor is given off a liquid to be ignited in air when exposed to a source of ignition.

<b>Name</b>	Flammable Liquid
<b>Class</b>	Class 3
<b>Cargo IMP Code</b>	RFL
<b>Label</b>  Minimum Dimensions: 100x100 mm Symbol (Flame): Black or White Background: Red	
<b>Description</b>	Flammable liquid e.g. paint, adhesives, kerosene, alcohols, etc.
<b>Note</b>	This label may also be printed with symbol (flame), text, numbers and border line shown in black on red background.

**CLASS 4 FLAMMABLE SOLIDS, SUBSTANCES LIABLE TO SPONTANEOUS COMBUSTION, SUBSTANCES WHICH, IN CONTACT WITH WATER, EMIT FLAMMABLE GASES**

<b>Name</b>	Flammable Solid
<b>Class/Division</b>	Class 4 / Division 4.1
<b>Cargo IMP Code</b>	RFS
<b>Label</b>  Minimum Dimensions: 100x100 mm Symbol (Flame): Black Background: White with seven vertical red stripes	
<b>Description</b>	Any solid material, which is readily combustible, e.g. Celluloid, or may cause or contribute to fire through friction, e.g. Matches, Nitmaptalane Solids which, under conditions encountered in transport, are readily combustible or may cause or contribute to fire through friction; self-reactive substances which are liable to undergo a strongly exothermic reaction; desensitized explosives which may explode if not diluted sufficiently. Examples: Matches, magnesium, sulphur, etc.

<b>Name</b>	Spontaneously Combustible
<b>Class/Division</b>	Class 4 / Division 4.2
<b>Cargo IMP Code</b>	RSC
<b>Label</b>  Minimum Dimensions: 100x100 mm Symbol (Flame): Black Background: Upper half white, lower half red	
<b>Description</b>	Spontaneously combustible Substances liable to spontaneous heating under normal conditions encountered in transport, or to heating up in contact with air, and being than liable to catch fire. Examples: Phosphorus (Yellow).

<b>Name</b>	Substances which in contact with water emit flammable gases
<b>Class/Division</b>	Class 4 / Division 4.3
<b>Cargo IMP Code</b>	RFW
<b>Label</b>  Minimum Dimensions: 100x100 mm Figures: Black or White Background: Blue	
<b>Description</b>	Dangerous when wet Substances, which, by interaction with water, are liable to become spontaneously flammable or to give off flammable gasses, e.g. Calcium carbide, Sodium, Potassium, Lithium, etc.
<b>Note</b>	This label may also be printed with symbol (flame), text, numbers and border line shown in black on blue background.

**CLASS 5 OXIDIZING SUBSTANCES AND ORGANIC PEROXIDE**

<b>Name</b>	Oxidizing Substances
<b>Class/Division</b>	Class 5 / Division 5.1
<b>Cargo IMP Code</b>	ROX
<b>Label</b> Minimum Dimensions: 100x100 mm Symbol (Flame over Circle): Black Background: Yellow	
<b>Description</b>	Oxidizing substances are which, in themselves are not necessarily combustible, but may generally cause or contribute to the combustion of other material by yielding oxygen. e.g. Ammonium nitrate fertilizer, Calcium chlorate, bleaching powder, potassium permanganate
<b>Note</b>	All subsidiary risk labels must show the class number.

<b>Name</b>	Organic Peroxides
<b>Class/Division</b>	Class 5 / Division 5.2
<b>Cargo IMP Code</b>	ROP
<b>Label</b>  Minimum Dimensions: 100x100 mm Symbol (Flame): Black or White - Black Background: Upper half red, lower half yellow	
<b>Description</b>	An organic material (liquid or solid) that is contains the bivalent structure –O-O- and may be considered derivatives of hydrogen peroxide in which one or both of the hydrogen atoms have been replaced by organic radicals. They are ready to be ignited by external flame and then burns with an accelerating rate; some substances react dangerously with others. e.g. Methyl, ethyl, ketone, peroxide, tert-butyl hydro peroxide as listed in Appendix C of the DGR. etc.
<b>Note</b>	Organic peroxides are thermally unstable substances, which may undergo exothermic, self-accelerating decomposition. In addition, they may have one or of the properties. Be liable to explosive decomposition, Burn rapidly, Be sensitive to impact or friction, React dangerously with other substances, Cause damage to the eyes. "This label may also be printed with symbol(flame), text, numbers and borderline shown in black on red background."

**CLASS 6 TOXIC AND INFECTIOUS SUBSTANCES**

<b>Name</b>	Toxic Substances
<b>Class/Division</b>	Class 6 / Division 6.1
<b>Cargo IMP Code</b>	RPB
<b>Label</b> Minimum Dimensions: 100x100 mm Symbol (Skull&Crossbones): Black Background: White	
<b>Description</b>	Liquids or solids, which are dangerous, if inhaled, swallowed or absorbed through the skin and liable to cause death or injury or to harm human health if swallowed, inhaled, or contacted by the skin. e.g. arsenic, nicotine, cyanide. Some are totally forbidden, e.g. Bromoacetone.
<b>Note</b>	Toxic Substances labels inscribed with the text "Toxic" or "Poison" are acceptable.

<b>Name</b>	Infectious Substances	
<b>Class/Division</b>	Class 6 / Division 6.2	
<b>Cargo IMP Code</b>	RIS	
<b>Label</b> Minimum Dimensions: 100 x 100mm (For small packages the dimensions may be 50 x 50 mm) Symbol (three crescents super-imposed on a circle) and inscription: Black Background: White		The lower part of the label should bear the inscription:  <b>INFECTIOUS SUBSTANCE</b> <b>In case of Damage or Leakage</b> <b>Immediately Notify Public Health Authority</b>
<b>Description</b>	Infectious substances are substances known to contain or reasonably expected to contain, pathogens. Pathogens are defined as micro-organisms incl. bacteria, viruses, rickettsia, parasite, fungi) or recombinant micro-organisms (hybrid or mutant) that are known or reasonably expected to cause infectious disease in humans or animals. However, they are not subject to the provisions of these Regulations for this division if they are unlikely to cause human or animal disease. Infectious substances are, subject to these Regulations for this division only if they are capable of spreading disease when exposure to them occurs.	
<b>Note</b>	All subsidiary risk labels MUST show the class number.	

**CLASS 7 RADIOACTIVE MATERIAL**

This class has no sub-divisions

Radioactive materials are articles or substances which spontaneously and continuously emit certain types of radiation (ionizing radiation) which can be harmful to health - but which, nevertheless, cannot be detected by any of the human senses (sight, hearing, smell, touch); these radiations can also affect other materials (particularly undeveloped photographic film and undeveloped X-Ray film) and they can be detected, and also measured with appropriate instruments.

Protective factors: Shielding material, keep your distance, time limitation.

Examples: Cobalt, iodine, cesium, radium, etc.

Radioactive materials are classified into 3 groups depending on their transport index (TI) values:

- (a) Category I (T.I.: 0, RRW)
- (b) Category II (T.I.: 0.1-1.0, RRY)
- (c) Category III (T.I.: 1.1-10, RRY)

<b>Name</b>	Radioactive
<b>Class/Category</b>	Class 7/ Category I White
<b>Cargo IMP Code</b>	RRW
<b>Label</b>  Minimum Dimensions: 100 x 100mm Symbol (Trefoil): Black Background: White	
<b>Description</b>	Radioactive material Category I - White.
<b>Note</b>	Slightly radioactive materials with radiation level lower than 0.5 mrem/hr on the package surface.

<b>Name</b>	Radioactive
<b>Class/ Category</b>	Class 7/ Category II Yellow
<b>Cargo IMP Code</b>	RRY
<b>Label</b> Minimum Dimensions: 100 x 100mm Symbol (Trefoil): Black Background: Top half yellow with white border, bottom half white	
<b>Description</b>	Radioactive material Category II - Yellow.
<b>Note</b>	Radiation level lower than 50 mrem/hr and a transport index not exceeding 1.

<b>Name</b>	Radioactive
<b>Class/ Category</b>	Class 7/ Category III Yellow
<b>Cargo IMP Code</b>	RRY
<b>Label</b> Minimum Dimensions: 100 x 100mm Symbol (Trefoil): Black Background: Top half yellow with white border, bottom half white	
<b>Description</b>	Radioactive material Category III - Yellow.
<b>Note</b>	Radiation level lower than 200 mrem/hr and a transport index not exceeding 10.

**Critically Safety Index Label**

<b>Name</b>	Radioactive
<b>Class</b>	Class 7
<b>Label</b> Minimum Dimensions: 100 x 100mm	 <div style="border: 1px solid black; padding: 5px; width: fit-content;"> <p><b>Text (mandatory):</b></p> <p>"FISSILE" in black on white in upper half of label.</p> </div>
<b>Description</b>	Critically Safety Index Label

<b>Name</b>	Radioactive
<b>Class</b>	Class 7
<p><b>Label</b></p> <p>Dimensions: The dimensions shown are minimums, where larger dimensions are used, the proportions must be maintained. The figure "7" must be 25 mm or larger.</p> <p>Background: Top half Yellow with white border, bottom half White</p>	
<b>Note</b>	The word "Radioactive" in the bottom half of the placard is optional.

**CLASS 8 CORROSIVES (RCM)**

<b>Name</b>	Corrosive
<b>Class</b>	Class 8
<b>Cargo IMP Code</b>	RCM
<b>Label</b> Minimum Dimensions: 100x100 mm Symbol (liquids spilling from two glass vessels and attacking a hand and a metal): Black Background: Upper half White, lower half Black with White border	
<b>Description</b>	Substances, which can cause severe damage by chemical action, when in contact with living tissue or, in the case of leakage will materially damage or even destroy (visible destruction to human skin tissue or has a severe corrosion rate on other materials) , e.g. Battery acids, mercury, sulphuric acid, etc.
<b>Note</b>	All subsidiary risk labels MUST show the class number.

**CLASS 9 MISCELLANEOUS DANGEROUS SUBSTANCES AND ARTICLES, INCLUDING ENVIRONMENTALLY HAZARDOUS SUBSTANCES**

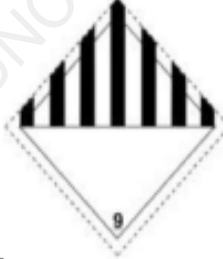
<b>Name</b>	Miscellaneous
<b>Class</b>	Class 9
<b>Cargo IMP Code</b>	RMD or ICE, RSB as applicable
<b>Label</b> Minimum Dimensions: 100x100 mm Symbol (seven vertical stripes in upper half): Black Background: White	
<b>Description</b>	RMD - Miscellaneous dangerous goods. ICE - Dry ice / carbon dioxide, solid RSB - Polymeric beads

<b>Name</b>	Miscellaneous
<b>Class</b>	Class 9
<b>Cargo IMP Code</b>	RLI, RLM as applicable
<b>Label</b> Minimum Dimensions: 100x100 mm Symbol (seven vertical stripes in upper half): Black Background: White	
<b>Description</b>	Lithium Batteries RLI - Fully regulated lithium ion batteries. RLM - Fully regulated lithium metal batteries

**8.1.7.2 Handling Labels**

**Magnetized Material**

<b>Name</b>	Magnetized Material
<b>Cargo IMP Code</b>	MAG
<b>Label</b> Minimum Dimensions: 110 x 90 mm Color: Blue on White	
<b>Description</b>	Any material which when packed for air transport, has a magnetic field strength of 0.159 A/m (0.002 GAUSS) or more at a distance of 2.1 meter (70 feet) from any point on the surface of an assembled package.
<b>Note</b>	“Magnetized Material” labels must be used on packages containing material with a high magnetic field strength.

**Cargo Aircraft Only**

<b>Name</b>	Cargo Aircraft Only
<b>Cargo IMP Code</b>	CAO
<b>Label</b> Minimum Dimensions: 120 x 110 mm For small packages of infectious substances (Class 6, Div. 6.2) dimensions may be halved. Color: Black on Orange	
<b>Note</b>	Packages which are bearing this label shall not be uploaded to a Pegasus aircraft.

**Cryogenics Liquid**

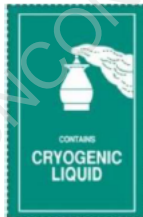
<b>Name</b>	Cryogenic Liquid
<b>Cargo IMP Code</b>	RCL
<b>Label</b> Minimum Dimensions: 75 x 105 mm Color: White on Green	
<b>Note</b>	<p>The words "Caution — may cause cold burn injuries if spilled or leaked" are optional and may be included.</p> <p>Must be used in addition to the non-flammable gas hazard label on packages and overpacks containing cryogenic liquids.</p>

**Package Orientation (This way up) Labels**

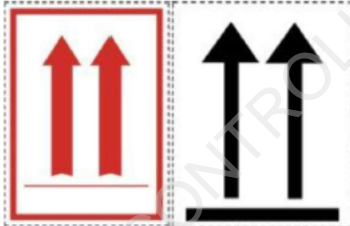
<b>Name</b>	Package Orientation (This Way Up)
<b>Labels</b> Minimum Dimensions: 74 x 105 mm Color: Red or Black on a contrasting background	
<b>Note</b>	<p>Must be used on combination packages and overpacks containing liquid dangerous goods, excluding packages containing flammable liquids in inner packaging of 120 ml or less infectious substances in primary receptacles not exceeding 50 ml or radioactive material. At least two labels must be affixed (on opposite sides.) Single packaging does not need to show arrows.</p>

**Battery-Powered Wheelchair and Mobility Aid Label**

<b>Name</b>	Battery-Powered Wheelchair and Mobility Aid
<b>Labels</b> Minimum Dimensions: Color: White on a blue background	

**Keep Away From Heat**

<p><b>Name</b></p>	<p>Keep Away From Heat</p>
<p><b>Label</b></p> <p>Minimum Dimensions: 74 x 105 mm Color: Red and Black on White Background or alternative colors.</p>	

**Lithium Battery**

<p><b>Name</b></p>	<p>Lithium Battery</p>
<p><b>Label</b></p> <p>Minimum Dimensions: 120 x 110 mm Color: The border of the label must have red diagonal hatchings. Text and symbols black on a white background.</p>	 <p>* Place for "Lithium ion battery" or "Lithium metal battery", as applicable.</p>

**Dangerous Goods in Excepted Quantities**

Some dangerous goods in very small quantities may be transported under a simplified procedure. Dangerous goods in excepted quantities are not permitted in or as checked or carry-on baggage nor in the mail. They can be carried:

- (a) Without the dangerous goods markings, hazard labels and shipper's declaration,
- (b) No entry in the NOTOC.
- (c) No use of dangerous goods loads information codes.
- (d) No restrictions concerning incompatibilities.
- (e) To be handled like normal cargo.
- (f) UN specification packaging is not required.
- (g) Completed handling label must be affixed.

<p><b>Name</b></p>	<p>Excepted Quantity</p>
<p><b>Label</b></p> <p>Minimum Dimensions: 100 x 100 mm Color: Hatching and symbol of the same color, black or red, on white or suitable contrasting background.</p>	
<p><b>Note</b></p>	<p>This label must be used to identify dangerous goods in excepted quantities, which are, as such, transportable by air.</p> <p>* The Class or, when assigned, the Division number(s) must be shown in this location.</p> <p>** The name of the shipper or of the consignee must be shown in this location if not shown elsewhere on the package.</p>

**Radioactive Material – Excepted Package**

<b>Name</b>	Radioactive Material — Excepted
<b>Cargo IMP Code</b>	RRE
<b>Label</b> Minimum Dimensions: 74 x 105 mm Color: The border of the label must have red diagonal hatchings. The label may be printed in black and red on white paper or it may be printed in red only on white paper.	
<b>Note</b>	The text "The information for this package need not appear on the Notification to Captain (NOTOC)" is optional and does not have to appear on the label.

**Limited Quantities Marking**

<b>Name</b>	Limited Quantity
<b>Label</b> Minimum dimensions: 100 x 100 mm The symbol "Y" must be placed in the centre of the mark and must be clearly visible. Top and bottom portions and line must be black, centre area white or suitable contrasting background.	
<b>Note</b>	For small packages the dimensions may be reduced to not less than 50 mm x 50 mm provided the marking remains clearly visible.

**8.1.7.3 REPLACEMENT OF LABELS**

When a member of Corendon Airlines or ground handler discovers that labels have become lost, detached or illegible, he must replace them in accordance with the information provided on the "Shipper's Declaration for Dangerous Goods". This requirement does not apply where the labels are found to be missing or illegible at time of acceptance

**8.1.7.4 LOADING OF CARBON DIOXIDE, SOLID (DRY ICE)**

Carbon dioxide, solid (dry ice) shipped by itself or used as a refrigerant for other commodities may be carried provided that Corendon Airlines has made suitable arrangements depending on the aircraft type, the aircraft ventilation rates, the method of packing and stowing, whether or not animals will be carried on the same flight and other factors. Corendon Airlines ensures that ground staff is informed that Carbon dioxide; solid (dry ice) is being loaded or is on board the aircraft.

For arrangements between the shipper and operator, see IATA Packing Instruction 904.

**8.1.7.5 LOADING OF LIVE ANIMALS WITH DANGEROUS GOODS**

Live animals should not be loaded in close proximity of cryogenic liquids or Carbon dioxide, solid (dry ice). As the vapor is emitted by Carbon dioxide, solid (dry ice) are heavier than air, they concentrate on the lower level of the hold. Therefore, live animals should be stowed above packages containing Carbon dioxide, solid (dry ice).

### 8.1.8 Dangerous Goods Notification to Commander (NOTOC)

The 'NOTOC' must be issued on the basis of the 'Shipper's Declaration' for all flights on which dangerous goods have been loaded.

The relevant staff of an operator of an aircraft in which dangerous goods are to be carried, except the ones in excepted quantities, must provide the pilot-in-command prior to departure of the aircraft, with information concerning the special cargo (dangerous goods and other special shipments) as determined in the definition 'Special Load Notification to the Captain'. NOTOC form may be issued manually or printed or in a similar method. In addition, information on dangerous goods to be loaded on a flight is communicated to the appropriate person(s) responsible for load control.

The notification must bear below information:

- i. If applicable, Air Waybill Number;
- ii. Proper shipping name and/or **UN/ID** number;
- iii. Class or division, and subsidiary risk(s) corresponding to the table(s) applied, and for Class 1, the compatibility group;
- iv. If applicable, Packing Group;
- v. For non-radioactive material, number of packages, exact loading location and, as required, net quantity or, if applicable, gross weight of each package, except:
  - a) For UN 1845: carbon dioxide, solid (dry ice), UN number, proper shipping name; classification, total quantity in each aircraft hold and offload airport;
  - b) For UN 3480 (Lithium ion batteries) and UN 3090 (lithium metal batteries), only the UN number, proper shipping name, class, total quantity at each loading location, and whether the package must be carried on a cargo only aircraft need be provided. UN 3480 (lithium ion batteries) and UN 3090 (lithium metal batteries) carried under a State exemption must meet all requirements of iv) and v).
- vi. For radioactive materials, number and category of packages, over packs or freight containers, exact loading location and, as applicable, transport index for each package;
- vii. Any restriction for transport on cargo aircraft only; (Not applicable in Corendon Airlines)
- viii. Offload airport;
- ix. If applicable, dangerous goods transported under a state exemption;
- x. An indication that aircraft loading personnel observed no evidence of damage to or leakage from packages, or leakage from ULDs, loaded onto the aircraft;
- xi. For a consignment consisting of multiple packages bearing the same UN number and proper shipping name only the total quantity of material and the smallest and largest package indication must be done on NOTOC.
- xii. For dry ice only UN number, PSN, class, total quantity for each hold and airport of unloading must be shown on NOTOC.

This information must be given prior to departure in written and in such a manner that the pilot-in-command must check the accuracy of it when needed. The pilot-in-command must indicate on either the NOTOC or by another way that he has received this information. In addition, the form must include the confirmation that there is no damage or leakage on the loaded packages.

Written information must be in use of pilot-in-command during whole flight.

One copy of written information must be kept at an easily accessible center till the transportation is ended at informed destination.

If possible a contact number for emergency response information may be provided for the pilot-in-command.

If the pilot-in-command verifies a transit flight, the written information must indicate dangerous goods loaded both at the previous stations and the ones on the aircraft.

The NOTOC form must be delivered to the commander in due time prior to departure in order to ensure that the take-off of the aircraft is not delayed because of additional checks to be made by the commander if he deems necessary.

The pilot-in-command must sign the relevant entry on NOTOC, in order to indicate that the information has been received. And NOTOC must be kept in cockpit during the flight in order to act accordingly in the event of an emergency.

A copy of signed NOTOC form which is also confirming the information has been given to captain is handed over to cargo staff for retaining and filing.

Information of any dangerous goods declared on the NOTOC, must be included in the Load Message (LDM) transmitted to subsequent stations.

The Signed NOTOC form must be retained and filed by loading supervisors at departure and arrival stations and shall be retained for a minimum period of 1 year after the flight on which the dangerous goods were transported.

\*Some dangerous goods are not required to be appeared on the information to PIC which is stated IATA DGR Table 9.5.A

The NOTOC form is issued;

- 1) In one copy for single sector flights,
- 2) In one copy for each station along the multi sector flight route, including the last station,
- 3) The boarding staff at transit stations and boarding competent at destination of arrival is obliged to keep one copy of NOTOC.

#### **8.1.8.1 NOTOC Forwarding**

A legible copy of all documentation, information and NOTOC (signed by Commander and the loading supervisor), shall be forwarded to Corendon Airlines Operation Control Centre(OCC) and Ground Operation department until the aircraft transporting the dangerous goods has arrived at the destination airport. .

**E-mail:** [occ@groundoperations@corendon-airlines.com](mailto:occ@groundoperations@corendon-airlines.com)  
[groundoperations@corendon-airlines.com](mailto:groundoperations@corendon-airlines.com)

The designated Corendon Airlines Operation Control personnel is responsible to distribute the information in NOTOC or NOTOC itself to required parties (i.e. local authority, emergency units, etc.) in case of incidents or accidents

See sample NOTOC form which is available in Section 10 – Forms

**8.1.8.2 The required load items for issuing NOTOC**

- Dangerous Goods

IMP Code	Meaning	Class	Division
REX	To be reserved for normally forbidden Explosives	1	1.1, 1.2, 1.3, 1.4F, 1.5 and 1.6
RCX	Explosives (CAO)	1	1.3C
RGX	Explosives (CAO)	1	1.3G
RXB	Explosives	1	1.4B
RXC	Explosives	1	1.4C
RXD	Explosives	1	1.4D
RXE	Explosives	1	1.4E
RXG	Explosives	1	1.4G
RXS	Explosives	1	1.4S
RFG	Flammable Gas	2	2,1
RNG	Non-Flammable Non-Toxic Gas	2	2,2
RCL	Cryogenic Liquid (Packing Instruction 202) - to replace RNG	2	2,2
RPG	Toxic Gas	2	2,3
RFL	Flammable Liquid	3	
RFS	Flammable Solid	4	4,1
RSC	Spontaneously Combustible	4	4,2
RFW	Dangerous When Wet	4	4,3
ROP	Organic Peroxide	5	5,1
ROX	Oxidizer	5	5,1
RPB	Toxic substance	6	6,1
RIS	Infectious Substance (UN 2814 or UN 2900)	6	6,2
RRW	Radioactive Material Category I-White	7	I-White
RRY	Radioactive Material Categories II-Yellow and III-Yellow	7	II-Yellow, III-Yellow
RCM	Corrosive	8	
ICE	Carbon dioxide, solid (dry ice)	9	
MAG	Magnetized Material	9	
RBI	Fully regulated lithium ion batteries (UN 3480) as per Section IA and IB of PI 965 or sodium ion batteries (UN3551) as per PI 976	9	
RBM	Fully regulated lithium metal batteries (UN 3090) as per Section IA and IB of PI 968	9	
RLI	Fully regulated lithium ion batteries (UN 3481) as per Section I of PI 966 and 967 or sodium ion batteries (UN 3552) as per Section I of PI 977 and PI 978	9	
RLM	Fully regulated lithium metal batteries (UN 3091) as per Section I of PI 969 and 970	9	
RMD	Miscellaneous Dangerous Goods	9	
RSB	Polymeric Beads/Plastics Moulding Compound (Packing Instruction 957)	9	

- Other Special Loads

IMP Code	Meaning
AVI	Live animal
DOC	Day old chick
EAT	Foodstuff
ELI	Lithium ion batteries excepted as per Section II of PI 966 and 967 or sodium ion batteries excepted as per Section II of PI 977 and PI 978
ELM	Lithium metal batteries excepted as per Section II of PI 969 and 970
FIL	Undeveloped films/Unexposed films
HUM	Human remains
LHO	Living human organs/blood
PEA	Hunting trophies, skin and all articles made from or containing part of species listed in CITES
PEF	Flowers
PEM	Meat
PEP	Fruits and vegetables
PER	Perishables
PES	Seafood/fish for human consumption
PIL	Pharmaceutical products
SWP	Sporting Weapon
VAL	Valuable cargo
WBD	Wheelchair Battery Dry
WBL	Wheelchair Battery Lithium-Ion
WBW	Wheelchair Battery Wet
WEA	Weapon

### 8.1.9 Loading and Stowage of Dangerous Goods

Before dangerous goods are loaded on an aircraft and after the unloading of dangerous goods from an aircraft, packages, over packs shall be inspected for evidence of damage or leakage and also prevented damage to packages. Leaking or damaged packages/over packs shall not be loaded on an aircraft and whenever after unloading leakage is visible the technical department shall be informed. Furthermore, a report shall be established.

Dangerous goods identified as suitable only for transport aboard cargo aircraft shall not be carried on Corendon Airlines aircraft. In this context passenger excludes crew members, operator's employees and authorized representative of an authority or person with duties in respect of dangerous goods or particular shipment on board that aircraft (e.g. animal stewards).

- **Flight Deck and Aircraft cabin:** Corendon Airlines does not transport any dangerous goods as cargo in the aircraft cabin occupied by passengers and on the flight deck.
- **Cargo Compartments:** Corendon Airlines ensures that dangerous goods are loaded, segregated, stowed and secured on an aircraft as specified in the ICAO Doc-9284 Technical Instructions for The Safety Transport of Dangerous Goods by Air.

- **Dangerous Goods Designated for Carriage Only on Cargo Aircraft:** Packages of DG bearing the cargo aircraft only label is not carried on CAI aircrafts.

It must be ensured that Dangerous Goods is not carried in an aircraft cabin occupied by passengers or crew members or on the flight deck, unless otherwise specified in the ICAO Doc-9284 Technical Instructions for The Safety Transport of Dangerous Goods by Air.

Dangerous Goods must be loaded segregated, stowed and secured as specified in the ICAO Doc-9284 Technical Instructions for The Safety Transport of Dangerous Goods by Air.

- Packages containing Dangerous Goods, which might react dangerously with each other, shall not be stowed on an aircraft next to each other or in a position that would allow interaction between them in the event of leakage. To maintain acceptable segregation between packages containing Dangerous Goods having different hazards, the segregation requirements shown in IATA DGR Table 9.3A must be observed. The segregation requirements apply based on all hazard labels applied on the package, irrespective of whether the hazard is the primary or subsidiary risk.
- Packages of DG with the label “Cargo Aircraft Only” are only allowed to be transported on cargo aircraft.
- Dangerous goods shall be separated from other cargo or incompatible materials in accordance with IATA published category restrictions. (Please see IATA DGR Table 9.3.A)
- General principles:
  - i. The cargo must be checked for proper labeling when picking up import or export cargo, if labels like, this side up, dangerous goods labels, perishable, live animals, valuable cargo etc., then precautions must be taken according to the situation by the handling agent company for the physical handling of the cargo and proper storage(s).
  - ii. Ensure that packaging, over pack or freight containing dangerous goods has been inspected for evidence of leaks and/or damage.
  - iii. Cargo handling agent will follow dangerous goods part of Cargo Operation Manual for the loading and securing dangerous goods on the aircraft in such a manner that will prevent any movement in flight that would change the orientation or damage the package.
  - iv. Depending on the category of the cargo, whether Dangerous Goods or General Cargo, handling must be made accordingly to avoid damage/spillage or incidents.
  - v. All care must be taken by the handling staff to ensure safe, efficient and correct handling.
  - vi. Damaged parcels are not allowed to be loaded, the package must agree with the loading list,
  - vii. Liquids are to be in an upright position,
  - viii. The package must be secured against movement,
  - ix. Light packages must be protected against heavier cargo,
  - x. Incompatibility must be checked,
  - xi. RRY- packages must be loaded on bottom of pallet or cargo compartment and
  - xii. Technical Instructions have to be observed, additional state and/or operator variations must be adhered to.

The principles for loading packages and/or over packs on a Corendon Airlines aircraft are listed below but not limited to:

- Damaged packages shall not be loaded.
- Dangerous goods in the aircraft must be secured in a manner that will prevent any movement in flight, which would change the orientation of the packages.
- An aircraft which has been contaminated by radioactive materials must be taken out of service immediately. It should not be returned into service until the radiation level at any accessible surface and the non-fixed contamination are not more than the values specified in the ICAO Doc-9284 Technical Instructions for The Safety Transport of Dangerous Goods by Air.
- Attention must be paid to packing groups.
- Leaking or damages packages, over packs or freight containers shall not be loaded onto an aircraft.

- When a package containing dangerous goods is found on an aircraft that appears to be damaged or leaking, it shall be removed from the aircraft and shall be inspected to ensure that no damage or contamination has occurred to the aircraft or its load.
- If a package is found leaking or damaged before arriving to the aircraft, it shall be safely removed from the transport device by the provider or other relevant authority, and safe disposal shall be arranged. In the case of leakage, an evaluation shall be conducted to ensure the remainder of the shipment is in proper condition for transport by air and that no other package, cargo or transport device has been contaminated or damaged.
- Handling instructions shall be followed.
- Segregations of dangerous goods table and incompatibility table shall be adhered to. For segregation of Packages Table refers to IATA DGR 9.3 A
- All regulations and restrictions of IATA Dangerous Goods Regulations and possible further authority restrictions are being followed.

### 8.1.10 Training Programs

#### Qualification of Employees Involved with the Dangerous Goods (DG)

Corendon Airlines is responsible to train the company staff involved in dangerous goods operations according to rules specified by Dangerous Goods Training (CBTA).

Accepted dangerous goods shall be properly classified, documented, certificated, described, packaged, marked, labeled and in a fit condition for transport in accordance with ICAO Doc-9284 Technical Instructions for The Safety Transport of Dangerous Goods by Air.

Corendon Airlines is also responsible to ensure that all non-Corendon Airlines ground handlers dealing with dangerous goods operations are properly trained.

Any personnel who may come into contact with DG during the performance of their duties shall receive training in the requirements commensurate with their responsibilities. The subject matter to which their various categories of personnel must be familiar is indicated in Dangerous Goods Training (CBTA).

- a. For flight crews and cabin attendants the familiarization training may be integrated in the emergency training.
- b. For staff engaged in the acceptance of dangerous goods and who have to take decisions on either acceptance or refusal of dangerous goods have to pass a function specific training organized by the operator.
- c. On completion of the training there must be a written examination which covers all items of the training program.
- d. Training programs must be approved by the Turkish DGCA before implementation

#### 8.1.10.1 Training Program Contents

The subjects which shall be covered by the training are specified in the Dangerous Goods Training (CBTA). Table shows which category of staff must receive which type of training. The depth to which training should be covered depends upon whether it is general familiarization or a function specific training.

#### 8.1.10.2 Recurrent Training

Recurrent training must be given at intervals of no longer than 24 months to personnel who received a function specific training. However, if recurrent training is completed within the final 3 months of validity of previous training, the period of validity extends from the date on which the recurrent training was completed until 24 months from the expiry date of that previous training.

**8.1.10.3 Training Records**

The participation of any training and recurrent training has to be recorded with the training subjects and date and duration of the courses. Record of Trainings should be in accordance with Dangerous Goods Training (CBTA).

**8.1.10.4 Survey of the Training**

An operator, not holding a permanent approval to carry dangerous goods, shall ensure the followings:

- Staff who are engaged in general cargo (and baggage) handling have received training to carry out their duties in respect of dangerous goods. As a minimum this training must cover the areas identified in Dangerous Goods Training (CBTA) and be to a depth sufficient to ensure that an awareness is gained of the hazards associated with dangerous goods, (how to identify them and what requirements apply to the carriage of such goods by passengers) and
- The following personnel:
  - i. Passenger Handling Staff,
  - ii. Flight Crew Members,
  - iii. Load Planners,
  - iv. Crew Members (Other than flight crew members)
  - v. Security staff employed by the operator who deal with the screening of passengers and their baggage, have received training which, as a minimum, must cover the areas identified in Dangerous Goods Training (CBTA) and be to a depth sufficient to ensure that an awareness is gained of the hazards associated with dangerous goods, how to identify them and what requirements apply to the carriage of such goods by passengers.

**8.1.11 Emergency Situations**

Corendon Airlines shall on request, provide any information required to minimize the hazards created by any DG carried.

In case of an in-flight emergency the commander should inform to ATS about the DG on board. The information should include the proper shipping names, class and subsidiary risks for which labels are required, the compatibility group for class 1 and the quantity and location of the DG aboard the aircraft.

In case of an incident or accident, Corendon Airlines shall give all information about the DG carried (including the procedures in appropriate manuals and accident contingency plans) to the authority of the State in which the aircraft accident occurred.

All incident and accidents occurred during acceptance, storage, transportation, loading and unloading of dangerous goods shall be reported through the current edition of IATA Dangerous Goods Occurrence Report by handling/cargo personnel to Corendon Airlines Ground Operation as soon as possible, but no later than 24 hours. (For contact information please see GOM chapter 1.1.3)

The agent must take action to report the accident or incident to the appropriate authority of the state of occurrence about such incident or accident within 72 hours (or in accordance with the state requirements) in accordance with IATA requirements. This report must also be forwarded to the Corendon Airlines Ground Operation department.

All information received by Corendon Airlines Ground Operation must be forwarded to Corendon Airlines Safety department through online safety reporting system (SERA) together with the soft copy of the dangerous goods occurrence report and any other related documents (i.e. photograph of the incident) with immediate effect. Corendon Airlines Safety Department is obliged to report the dangerous goods incident or accidents to

the national authority within 72 hours of becoming aware of the occurrence, unless exceptional circumstances prevent this.

Reportable incidents, accidents, occurrences may include but are not limited to:

1. Dangerous goods accidents and incidents where dangerous goods carried as cargo may be involved,
2. Any occasion when undeclared or mis-declared dangerous goods are discovered in cargo or mail during aircraft loading,
3. Dangerous goods are discovered to have been carried when not loaded, segregated, separated and secured in accordance with IATA DGR 9.2 or 9.3,
4. Dangerous goods are discovered to have been carried without information having been provided to the PIC in accordance with IATA DGR 9.5.1.1 Notification to Captain.
5. Spillage, contamination, damaged and leaking packages
6. Any occasion when dangerous goods not permitted under IATA DGR Subsection 2.3 are discovered either in the baggage or on the person of passengers or crew members,
7. Missing and incorrect Notoc
8. Incorrect loading on aircraft
9. Missing contents or suspected theft
10. Misrouted packages

Initial report and any subsequent report shall be as precise as possible and contained such of the following data that are relevant:

- Date of the incident or accident or the finding of undeclared or undeclared dangerous goods;
- Location, the flight number and flight date;
- Description of the goods and the reference number of the air waybill, pouch, baggage tag, ticket, etc.;
- Proper shipping name (including the technical name, if appropriate) and UN/ID number, when known;
- Class or division and any subsidiary risk;
- Type of packaging, and the packaging specification marking on it;
- Quantity;
- Name and address of the shipper, passenger, etc.;
- Any other relevant details;
- Suspected cause of the incident or accident;
- Action taken;
- Any other reporting action taken; and
- Name, title, address and telephone number of the person making the report.

Copies of relevant documents and any photographs taken should be attached to a report.

#### **8.1.11.1 Accidents Involving Dangerous Goods**

Handling of accidents involving dangerous goods depends on the extent and potential consequences of the damage.

There are two kinds of damages:

- Damage to the outer package only (except for infectious and radioactive substances)
- Damage to the outer package and the content of it (including infectious and radioactive substances)

In principle, all damages must be handled in accordance with the following procedure.

If it is detected that the outer package of a dangerous good is damaged, notwithstanding whether the content leaked,

- Assistance is asked if necessary

- Supervisor is informed about the case
- All packages of the same consignment are checked

#### 8.1.11.2 Second Degree Damages

Damage to the outer package only (except for infectious and radioactive substances):

If any damage (tear, crushing etc.) is detected on the outer package without the sign of leaking, the following are done:

- How the damage occurred where is investigated and the responsible person is identified;
- The package is placed in a safe place;
- If the package has been found in damaged condition on board the aircraft, the authorized person of the station is immediately notified and the aircraft is searched against the possibility of any latent damage.
- A detailed report describing the type and extent of the damage is written.

The outer package without leaking is treated after replacement of the package or making it convenient for transportation. In principle, the package is carried if it has been made in strict compliance with the packaging instructions in the DGR Section 5.

#### 8.1.11.3 First Degree Damages

Damage to the outer package and its content (including infectious and radioactive substances):

If a leaking is detected in a package containing a dangerous good due to damage, the package must be immediately removed from the aircraft, the crew informed, and the section where the leaking occurred cleaned. After detection of a leaking, the loading personnel must verify that the rest of the consignment is free of any damage and that the other cargoes were not affected from the leaking. Potential damages that may occur during acceptance, storage, loading, carrying and unloading of the dangerous goods and the actions to be taken against such damages are given in the table of "Emergency Guidelines for Accidents Involving Dangerous Goods" according to the classes of the dangerous goods.

If a leakage has occurred from the dangerous good, the following procedure must be implemented in addition to the aforesaid measures:

- Passengers and crew are disembarked from the aircraft and taken under protection;
- Other cargoes and articles are removed from the aircraft and taken under protection;
- If possible, the package and its surrounding are isolated;
- Emergency services of the local airport are called.

Measures to be taken are determined according to the extent of the damage. The following must be done under any circumstances:

- The supervisor is notified about the damage;
- The package is isolated;
- Contact with the content of the package is prevented.

If the content comes into contact with body or cloth of a person, the following must be done immediately:

- The contaminated cloth is worn off;
- The contact site is washed with plenty of water;
- Eating, drinking and smoking is forbidden;
- Hands are kept away from the eyes, mouth and nose;

- Medical assistance is asked.

Persons exposed to the dangerous goods as a result of an accident must stay at the scene of accident until their names are recorded for purposes of medical examination. Thereafter, the instructions of the specialists must be complied with and the shipper and consignee of the dangerous goods are informed about the accident.

#### 8.1.11.4 Radioactive Substances

As to the radioactive substances, it must always be kept in mind that the radioactive substances are extremely harmful, that the radiation, once freed, cannot be contained, and that radiation intake may occur through contacting, swallowing and breathing. When any damage is detected in a radioactive consignment, emergency measures must be taken absolutely and immediately.

In essence, safety measures are consisted of taking measures for protection of the people and calling the local nuclear centers for urgent intervention to the accident. Although such centers are notified, yet there are certain measures that must be taken until the specialists arrive at the scene of accident:

- If the damaged package is not leaking, a danger zone must be set up around the package and everybody must be kept away from the package as much as possible until the arrival of the specialists.
- If the damaged package is leaking, the persons exposed to the radiation must leave the equipment, devices, personal articles and all the cloths (including the footwear) near the package, take whole body shower under pressurized water with soap/shampoo, and thereafter act in accordance with the instructions of the specialists.

All persons suspicious of being exposed to radiation must be subject to medical tests.

- While the specialists are waited for, a danger zone must be set up at a safe distance away from the package in order to prevent the exposure of other persons to radiation.
- Necessary measures must be taken to prevent contact of anybody with the leaking substance.
- Shipper and consignee of the dangerous substance must be notified about the accident.

**Warning:** If any of the cargo compartments was affected from the radiation or spillage of the radioactive substance, loading and unloading operations nearby the area exposed to the radiation must be stopped immediately.

The attained personnel by the cooperation would make measurement in case of any leaking and the transportation of radio-active materials in cargo. The following cleaning would be done if the measurement of radio-active materials is below the danger level or in case of evaporation ALO-TAEK 172 must be called. The area must be kept isolated till the authorized personnel come.

Please see the ICAO Emergency Response Guidance Book (DOC 9481).

#### 8.1.11.5 REMOVAL OF CONTAMINATION

If material is found leaking or damaged while on the aircraft arrangements shall be made for its removal by an appropriate authority or organization. In this case the remainder of the consignment shall be thoroughly inspected to ensure it is in a proper condition for transport.

In case an aircraft is involved in a contamination case, the Commander has to adhere to the following operational instructions:

- Any contamination found as result of leakage or damage of dangerous goods is removed without delay; and
- An aircraft, which has been contaminated by radioactive materials is immediately taken out of service and not returned until the radiation level at any accessible surface and the no fixed contamination are not more than the values specified in the in the ICAO Doc-9284 Technical Instructions for The Safety Transport of Dangerous Goods by Air.

**8.1.11.6 EMERGENCY RESPONSE GUIDANCE FOR FLIGHT CREW MEMBERS**

If an emergency situation occurs during flight, flight crew members should:

- Follow the appropriate aircraft emergency procedures for fire or smoke removal,
- No smoking signs ON,
- Consider landing as soon as possible,
- Consider turning off non-essential electrical power,
- Determine source of smoke/fumes/fire, identify the item,
- For dangerous goods incidents in the passenger cabin, see cabin crew and co-ordinate cabin crew actions,
- Determine emergency response drill code,
- Use guidance from the current ICAO Doc 9284 "Emergency Response Guidance for Aircraft Incident Involving Dangerous Goods" to help deal with incident
- If the situation permits, the commander must inform the appropriate Air Traffic Services Unit of any dangerous goods on board the aircraft. This information must include the proper shipping name and/or the UN number, the class/division, identified subsidiary risks, the compatibility group for explosives, the quantity and the location on board or a telephone number where a copy of the information provided to the commander.

After landing, crew members should:

- Disembark passengers and crew before opening any cargo compartment doors,
- Inform ground personnel/emergency services of nature of item and where stowed,
- Make appropriate entry in the Aircraft Maintenance License.

**8.1.11.7 EMERGENCY RESPONSE CHART**

1. COMPLETE APPROPRIATE AIRCRAFT EMERGENCY PROCEDURES. 2. CONSIDER LANDING AS SOON AS PRACTICABLE. 3. USE DRILL FROM THE CHART BELOW.						
DRILL NO.	INHERENT RISK	RISK TO AIRCRAFT	RISK TO OCCUPANTS	SPILL OR LEAK PROCEDURE	FIREFIGHTING PROCEDURE	ADDITIONAL CONSIDERATIONS
1	Explosion may cause structural failure	Fire and/or explosion	As indicated by the drill letter(s)	Use 100% oxygen; no smoking	All agents according to availability; use standard fire procedure	Possible abrupt loss of pressurization
2	Gas, non-flammable, pressure may create hazard in fire	Minimal	As indicated by the drill letter(s)	Use 100% oxygen; establish and maintain maximum ventilation for "A", "I" or "P" drill letter	All agents according to availability; use standard fire procedure	Possible abrupt loss of pressurization
3	Flammable liquid or solid	Fire and/or explosion	Smoke, fumes and heat, and as indicated by the drill letter(s)	Use 100% oxygen; establish and maintain maximum ventilation; no smoking; minimum electrics	All agents according to availability; no water on "W" drill letter	Possible abrupt loss of pressurization
4	Spontaneously combustible or pyrophoric when exposed to air	Fire and/or explosion	Smoke, fumes and heat, and as indicated by the drill letter(s)	Use 100% oxygen; establish and maintain maximum ventilation	All agents according to availability; no water on "W" drill letter	Possible abrupt loss of pressurization; minimum electrics if "F" or "H" drill letter
5	Oxidizer, may ignite other materials, may explode in heat of a fire	Fire and/or explosion, possible corrosion damage	Eye, nose and throat irritation; skin damage on contact	Use 100% oxygen; establish and maintain maximum ventilation	All agents according to availability; no water on "W" drill letter	Possible abrupt loss of pressurization
6	Toxic*, may be fatal if inhaled, ingested, or absorbed by skin	Contamination with toxic* liquid or solid	Acute toxicity, effects may be delayed	Use 100% oxygen; establish and maintain maximum ventilation; do not touch without gloves	All agents according to availability; no water on "W" drill letter	Possible abrupt loss of pressurization; minimum electrics if "F" or "H" drill letter
7	Radiation from broken/unshielded packages	Contamination with spilled radioactive material	Exposure to radiation, and personnel contamination	Do not move packages; avoid contact	All agents according to availability	Call for a qualified person to meet the aircraft
8	Corrosive, fumes disabling if inhaled or in contact with skin	Possible corrosion damage	Eye, nose and throat irritation; skin damage on contact	Use 100% oxygen; establish and maintain maximum ventilation; do not touch without gloves	All agents according to availability; no water on "W" drill letter	Possible abrupt loss of pressurization; minimum electrics if "F" or "H" drill letter

DRILL NO.	INHERENT RISK	RISK TO AIRCRAFT	RISK TO OCCUPANTS	SPILL OR LEAK PROCEDURE	FIREFIGHTING PROCEDURE	ADDITIONAL CONSIDERATIONS
9	No general inherent risk	As indicated by the drill letter	As indicated by the drill letter	Use 100% oxygen; establish and maintain maximum ventilation if "A" drill letter	All agents according to availability	None
10	Gas, flammable, high fire risk if any ignition source present	Fire and/or explosion	Smoke, fumes and heat, and as indicated by the drill letter	Use 100% oxygen; establish and maintain maximum ventilation; no smoking; minimum electrics	All agents according to availability	Possible abrupt loss of pressurization
11	Infectious substances may affect humans or animals if inhaled, ingested or absorbed through the mucous membrane or an open wound	Contamination with Infectious substances	Delayed infection to humans or animals	Do not touch. Minimum re-circulation and ventilation in affected area	All agents according to availability. No water on "Y" drill letter	Call for a qualified person to meet the aircraft
12	Fire, heat, smoke, toxic and flammable vapour	Fire and/or explosion	Smoke, fumes, heat	Use 100% oxygen; establish and maintain maximum ventilation	All agents according to availability. Use water if available	Possible abrupt loss of pressurization; consider landing immediately
DRILL LETTER	ADDITIONAL RISK	DRILL LETTER	ADDITIONAL RISK			
A	ANAESTHETIC	S	SPONTANEOUSLY COMBUSTIBLE OR PYROPHORIC			
C	CORROSIVE	W	IF WET GIVES OFF TOXIC* OR FLAMMABLE GAS			
E	EXPLOSIVE	X	OXIDIZER			
F	FLAMMABLE	Y	DEPENDING ON THE TYPE OF INFECTIOUS SUBSTANCE, THE APPROPRIATE NATIONAL AUTHORITY MAY BE REQUIRED TO QUARANTINE INDIVIDUALS, ANIMALS, CARGO AND THE AIRCRAFT			
H	HIGHLY IGNITABLE	Z	AIRCRAFT CARGO FIRE SUPPRESSION SYSTEM MAY NOT EXTINGUISH OR CONTAIN THE FIRE; CONSIDER LANDING IMMEDIATELY			
i	IRRITANT / TEAR PRODUCING					
L	OTHER RISK LOW OR NONE					
M	MAGNETIC					
N	NOXIOUS					
P	TOXIC* (POISON)					

\* Toxic has the same meaning as poison.

**8.1.11.8 Dangerous Goods Emergency Response KIT**

Dangerous Goods KIT is available in Emergency Kits Bag which is located on all Corendon Airlines aircrafts for Cabin Crew Members. The kit is to be used by the Crew members in case of emergency situation related with dangerous goods incident and/or accident.

This dangerous goods kit contains:

- Polyethylene bag
- Absorbent towel
- Gloves
- Seals

Please refer to CCM Chapter 09 for more information.

### **8.1.12 SEGREGATION, SEPARATION AND STOWAGE OF DANGEROUS GOODS**

Dangerous goods shall be separated, stowed and secured on the aircraft as required. That is, segregating the packages from each other when they contain incompatible dangerous goods, securing packages as such that their orientation will not change due to in-flight acceleration forces and will neither be damaged.

Corendon Airlines will ensure that dangerous goods are not carried in an aircraft cabin occupied by passenger or on the flight deck, unless otherwise specified in in the ICAO Doc-9284 Technical Instructions for The Safety Transport of Dangerous Goods by Air.

#### **8.1.12.1 SEGREGATION OF DANGEROUS GOODS**

Packages containing Dangerous Goods, which might react dangerously with each other, must not be stowed on an aircraft next to each other or in a position that would allow interaction between them in the event of leakage. To maintain acceptable segregation between packages containing Dangerous Goods having different hazards, the segregation requirements shown in Table 9.3A of IATA DGR Manual must be observed.

Table 9.3A scheme applies irrespective of whether the hazard is primary or subsidiary risk. Packages containing Dangerous Good with multiple hazards in the class or divisions, which require segregation in accordance with Table 9.3A, need not be segregated from packages bearing the same UN number

#### **8.1.12.2 SEPARATION OF EXPLOSIVE SUBSTANCES AND ARTICLES**

Only explosives in Division 1.4 compatibility group S, are permitted to be transported on passenger aircraft. The extent to which explosives may be stowed together in an aircraft is determined by their compatibility. Explosives are considered to be compatible if they can be stowed together without significantly increasing either the probability of an accident or, for a given quantity, the magnitude of the effects of such an accident.

#### **8.1.12.3 SEPARATION OF TOXIC AND INFECTIOUS SUBSTANCES**

Packages having a Division 6.1 or a Division 6.2 label must not be stowed in the same compartment with:

- Animals;
- Foodstuffs;
- Feed; or
- Other edible substances intended for consumption by humans or animals;

#### **8.1.12.4 STORAGE OF ORGANIC PEROXIDES AND SELF-REACTING SUBSTANCES**

During the course of transport, packages or unit load devices containing self-reactive substances of Division 4.1 or organic peroxides of Division 5.2 must be shaded from direct sunlight and stored away from all sources of heat in a well-ventilated area and not over stowed with other cargo. See IATA DGR 9.1.3 for conditions of acceptance.

## **8.2 CARRIAGE OF WEAPONS, AMMUNITION AND ELECTRONIC DEVICES**

### **8.2.1 Procedures for Carriage of Firearms and Weapons**

The general rules about carriage of weapons/ammunitions in airside, landside and on board on an aircraft are as follows;

Anybody other than authorized personnel in an airport terminal and security restricted areas and ones who obtained a permission cannot carry firearms. Carriage of weapons on the hold and in hold baggage on board a national or a foreign aircraft is carried out in accordance with the Turkish legislation.

All kinds of weapons, ammunitions, war materials, military materials, defense materials and dangerous goods excluding protection, escort and police-military travel implementations/activities cannot be carried on board aircraft in accordance with the national laws without meeting the necessary security provisions and without obtaining the permission from the relevant states. These kinds of carriages are carried out within the scope of the article 93 of Turkish Civil Aviation Law No.2920.

It shall be checked through the system [through TIMATIC (Travel Information Manual Automatic)] by the personnel assigned for check-in process prior to generation of baggage tags for any weapon whether or not there are any special regulations applicable for carriage of firearms in force in the country of destination and the countries of transit/transfer stations.

Corendon Airlines may refuse to carry it unless Corendon Airlines is informed of the use of weapons before the flight.

#### **8.2.1.1 Passenger Weapons and Ammunition**

Corendon Airlines shall comply with the provisions of international / national and airport legislation regarding carriage of weapons. Acceptable kinds of weapons are carried in the hold of an aircraft and inaccessible to passengers at all times. Airport security authority processing a passenger carrying a weapon reviews the armed individual's credentials. These credentials shall include a full-face picture of the armed individual, the signature of the authorizing officer and the official seal of the armed individual's service. If there is a licensed weapon belonging to a passenger, **the "Corendon Airlines Weapon Delivery Form"** or another form accepted by airport authority or the relevant parties may be used.

See the sample of **Corendon Airlines Weapon Delivery Form** - which is available in Section 10 – Forms.

It must be ensured that an authorized/Airport Police at Weapon Delivery Desk and duly qualified person has declared the weapon not to be loaded; the weapon is stowed in a place that is inaccessible to any unauthorized person and the carriage of a weapon is legally permitted by all State(s) involved, including the State and State(s) of flight departure, transit and arrival.

##### **8.2.1.1.1 Procedure at Departing Station:**

- The weapon, ammunition/ bullets and the charger are separated as appropriately and put in a single bag.
- The Law enforcement officer or authorized agent who takes over the weapon, magazine, fills in a form (**Weapon Delivery Form**) whereby stating clearly the details of the flight, of the weapon and the owner of the weapon.
- The Law enforcement officer or authorized agent puts the weapon and its ammunition into a bag, and ensures their transfer to the aircraft. It must be ensured also that the weapon is loaded into the correct cargo compartment (Compartment 1).
- One copy of the delivery-form will be retained by the departing station, one by the owner and the remaining copies will be with the weapon.
- As soon as the security bag consisting of weapon(s), magazine(s) and ammunition(s) is loaded onto the aircraft hold 1, the cargo door will be closed and will not be opened again without obtaining approval by the commander.

- The Ground Service Provider must enter an indication referring to the weapon on board as SI at LDM message as piece/weight. The weight of the weapon must also be considered at load calculations. This message will be sent to transit/transfer and arrival stations.
- As Sample below:

**LDM**

**CAI999/04.TCTJI.Y189.2/4**

**-FRA.140/40/4.T2546.2/750.3/1796.PAX/180.PAD/0**

**SI Hold one/Section11/ Sec.Item/01 piece**

#### **8.2.1.1.2 Procedure at Arrival Station:**

- The Ground Service Provider at arriving station must immediately convey the information received on the LDM to the local security office or to the authorized Agent.
- The remaining copies of the delivery-forms will be handed over to the Law-enforcement officer at the arrival weapon delivery desk by the authorized agent who picks up the weapon(s) and ammunition(s) from the aircraft and takes them to the weapon delivery desk. The weapon(s) and ammunition(s) will be returned to the owner at this location after obtaining the signature(s) from the owner(s) on the weapon delivery-form.
- In case there is no Delivery-form of Corendon Airlines available, the documents / forms of the Local Authority/ Ground Service Provider must be used

#### **8.2.1.2 Weapons of Law Enforcement Officers in Cabin**

The procedures to be carried out about firearms of High-Level State Official's escorts in the State Protocol List on board civil aviation aircraft are written in the National Civil Aviation Security Program and its relevant Annex.

Within this scope, the procedures on the carriage of VIP escorts' firearms on board Turkish registered civil aviation aircraft to be followed are as follows;

- a) The implementation covers just the carriage of VIP escorts' firearms on board Turkish registered civil aviation aircraft in one-off flights.
- b) VIP's escorts shall be the State officials.
- c) In case VIP's escorts written in the Protocol List NCASP Annex-26-a travel with VIP passengers, they can carry their firearms with them in an aircraft cabin by following the provisions. The other VIP's escorts shall be subjected to the firearms delivery procedures applicable to passengers.
- d) If VIP's escorts travel with the VIP, this situation is accepted as a Duty Order. If VIP's escorts travel alone, VIP's escorts shall be subjected to the firearms delivery procedure applicable to the other passengers.
- e) With this arrangement, DGCA is understood to have given permission for the procedure of the carriage of VIP's escorts' firearms in an aircraft cabin in general.
- f) In case any firearm or any other ammunition, items are used in an aircraft cabin, VIP's escort personally shall be responsible to persons and air carrier operator.
- g) In any situation requiring secrecy as a duty requirement, it shall be acted in accordance with secrecy criteria and procedures.
- h) Within the framework of a training written in the NCASP Annex-26-c by DGCA in accordance with the international standards, VIP's escorts shall be given this training on the carriage of firearms on board an aircraft cabin by their institutions/departments. At the end of the training, VIP's escorts to carry firearms shall ensure a written Declaration of Conformity written in the NCASP Annex-26-b covering

their authorities and responsibilities or when training certificates are given, this Declaration of Conformity shall be written in the training certificate.

- i) The registration procedure of VIP's escorts with firearms to board an aircraft shall be carried out by (Airport) VIP Police Bureau in VIP lounge before the flight. The registration shall include the information about VIP escorts, their firearms and flight details.  
Moreover, if there will be a transfer flight, this information shall be written and be given to the transfer airport authority.
- j) During reservation phase or when boarding pass is issued in VIP lounge, VIP's escorts shall notify air carrier operator. On the issued passenger manifest, a mark stating the VIP's escorts with firearms shall be recorded for them and **Weapon NOTOC form** prepared by ground handling staff shall be given to Senior Cabin Crew Member and the Commander. Moreover, if VIP's escorts deem necessary, they can notify the Senior Cabin Crew Member and the Commander. If their seats are changed, SCCM and Commander shall be informed again

See the sample of **Corendon Airlines Weapon NOTOC Form** - which is available in Section 10 – Forms.

#### **8.2.1.3 VIP's Escorts Who Carry Their Firearms in an Aircraft Cabin**

- With them without drawing passengers' attention by removing the bullet in the chamber and removing to magazine and without firing the firearm or in a closed and locked bag by removing the bullet in the chamber and removing the magazine and without firing the firearm.
- Commander will be notified prior to the commencement of a flight when the carriage of weapons on board an aircraft via **Weapon NOTOC Form** by the ground handling company personnel
- Weapon NOTOC form shall include;
  - i. The number of authorized armed persons on board the aircraft
  - ii. The location(s) of such persons.
- This form shall be prepared for each Law Enforcement.

#### **8.2.1.4 The Protocol List of the High Level State and Government Officials**

Security escorts written in the below Protocol List who travel with the VIPs can carry their firearms with them in an aircraft cabin.

- President of Turkey,
- Speaker of the Turkish Grand National Assembly-TGNA/TBMM and Deputy Speakers of TGNA/TBMM,
- Prime Minister and Deputy Prime Ministers,
- Commander of Turkish Armed Forces,
- Main Opposition Party Leader,
- Former Presidents,
- President of Constitutional Court,
- First President of Supreme Court,
- President of Council of State,
- Members of Council of Ministers,
- Under Secretary of National Intelligence Organization,
- The spouse and children of the High Level State and Government Officials listed above in this section,
- All Acting High Level State and Government Officials when any of the High Level State and Government Officials listed above in this section is abroad/in a foreign country

#### **8.2.1.5 Police, Customs Officers and Authorized Personnel Boarding Aircraft**

Airport Police, Customs Officers and other personnel authorized by DGCA/CAA or Airport Competent Authority may request to get on an aircraft for performing any kind of security or customs related issues.

There is no international and national legislation prohibiting Airport Police, Customs Officers and other personnel authorized by DGCA/CAA or Airport Competent Authority from carrying a weapon on board the aircraft on the ground. SCCM shall inform the Commander of the situation. The flight crew compartment door shall be closed and locked by flight crews when armed airport police, customs officers and other personnel authorized by DGCA/CAA or airport competent authority are on board the aircraft on the ground

**See Chicago Convention Article 16-Search of Aircraft.**

#### **8.2.1.6 Sporting Weapons and Ammunition**

Weapons (hunting or sporting weapons) and any other objects which may be considered to be used as a life-threatening material (e.g. antiquities, souvenirs, knives, scissors, axes, hatches, pickaxes etc.) are not permitted to be taken into passenger cabin but may be carried in hold baggage/checked baggage in the cargo compartment, in compliance with IATA Dangerous Goods Regulations and the Turkish National Civil Aviation Security Program Annex 17.

The passenger shall observe the regulations for export, import and transit of weapons and ammunition, applicable in the country of his departure, destination and of any country he may transit.

##### **8.2.1.6.1 Weapon**

- The weapon shall be secured and not loaded with ammunition.
- The weapon shall be packed in a break proof box/bag (e.g. a marketed gun case).
- A hold baggage/checked baggage tag must be attached to the box/bag.
- The box/bag must be loaded into the cargo compartment.

##### **8.2.1.6.2 Ammunition**

- Only ammunition for small arms (e.g. hunting or sporting arms) up to the maximum of 5 Kg gross weight per passenger and only in hold baggage/checked baggage may be accepted. The following procedure shall be followed:
  - i. The quantity shall not exceed 5 Kg for each passenger.
  - ii. It shall be securely boxed (e.g. customary trade packing)

##### **8.2.1.7 In-Flight Security Officer - IFSO**

The requirements and provisions written in the Turkish Civil Aviation Law, the article no: 40 (updated by the Government) and relevant legislation shall be valid for IFSO/Sky Police/Air Marshall, when necessary. The requirements and provisions written in NCASP shall be valid for IFSO/Sky Police/Air Marshall, when required

#### **8.2.2 Rules for Use of Portable Electronic Devices**

**Transmitting Portable Electronic Devices (PEDs):** Any devices that can send or receive data by wireless means, such as mobile-phones and tablets, may be used during all phases of the flight **provided they transmit/receive capabilities (e.g. Bluetooth and Wi-Fi) are switched off. Alternatively, if the device has 'Flight Mode' capability, this shall be enabled.**

Such devices shall be safely secured in the customers' hand (handheld) or a pocket during taxi, take-off and landing. Larger devices (e.g. laptops) shall be switched off and stowed away safely during taxi, take-off and landing. Accessories, such as headphones, must not obstruct access to the aisle. If the data transmission capability cannot be switched off (whilst the device is operating), the device itself shall be switched off for the duration of the flight.

**Non-Transmitting Portable Electronic Devices (PEDs):** These could include, but are not limited to, items such as DVD players, electronic games, music players and personal cameras. Such devices shall be safely secured in the customers' hand (handheld) or a pocket during taxi, take-off and landing. Larger devices shall be stowed away safely during taxi, take-off and landing.

**Laptops and notebooks:** Such devices may be used during boarding and during flight but not during taxi, take-off and landing. Any built-in data connectivity such as Bluetooth or Wi-Fi shall be disabled. These devices must be stowed away safely during taxi, take-off and landing since they could hinder an emergency evacuation.

If you require more information, please refer to the table below which includes a list of PEDs which can be used onboard by phase of flight.

Phase	Boarding/ Disembarkation	Extended Ground Delay (If L1 is open and PIC permits)	Taxi and Take-off	Cruise Level	Descent, Landing and taxi to gate (Until L1 is open)
Mobile and Smart phones	Yes	Yes	Yes (Flightmode)	Yes (Flightmode)	Yes (Flightmode)
Power Banks	No	No	No	No	No
Laptops, Notebooks	Yes	Yes	No	Yes	No
Tablet computers, E-readers	Yes	Yes	No	Yes	No
Mp3 Player	Yes	Yes	No	Yes	No
Electronic Games	Yes	Yes	No	Yes	No
Personal Headphones	Yes	Yes	No	Yes	No
Personal camera	Yes	Yes	No	Yes	No
Lithium battery operated toys and drones	No	No	No	No	No

## 9. GOVERNMENT CLEARANCE REQUIREMENTS

### 9.1. GENERAL

#### a. International Air Traffic Rights

**There are eight (8) basic traffic rights for using airspace:**

- i. A carrier can operate an international air service from origin to destination via another country's airspace.
- ii. A carrier has the right to land in a country due to technical reasons while operating between two points.
- iii. A carrier can carry passenger/cargo/mail from its own country to another country.
- iv. A carrier can carry passenger/cargo/mail/form a country to its own country.
- v. A carrier can operate between two countries on condition that flight departs/finalizes from/to its own country.
- vi. A carrier can operate between two countries on condition that flight will not depart/finalize from/to its own country.
- vii. A carrier can carry passenger / cargo / mail between two other countries via using its own airspace.
- viii. A carrier can carry passenger / cargo/ mail between two points which are in the same country.

**b. ICAO and WORLD HEALTH ORGANIZATION (WHO) states have agreed upon the following standard reporting documents published in ICAO Annex 9 and in WHO International Health Regulations.**

- i. General Declaration
- ii. Passenger manifest
- iii. Embarkation/disembarkation cards

### 9.2. GENERAL DECLARATION

- a. The General Declaration (Gen – Dec) is the basis report to the authorities as mentioned above furnishing the information and customs authorized at departure, transit and arrival.
- b. It will be prepared at the station of origin for the entire flight and completed by each station where the GEN-DEC must be handed to the authorities.
- c. When a crew change (complete or partial) is planned enroute, the station concerned has to prepare a new GEN-DEC for the remaining sector flight.

#### **Distribution to**

Original Copy Custom Office,

2<sup>nd</sup> Cabin Crew

3<sup>rd</sup> Station

### 9.3. PASSENGER MANIFEST

**a.** The passenger manifest is supplement to the Gen-Dec. It is still required by some states demanding more detailed information on passengers than contained in the GEN-DEC. A passenger manifest will be prepared when required according to country regulations:

- i. By authorities at the own stations showing passengers and/or
- ii. By authorities at subsequent stations, showing passengers disembarking there/ and/or,
- iii. By authorities at subsequent transit stations, showing passengers in transit on the same flight.

**b.** Most countries requiring a passenger manifest will accept a consolidated manifest for several destinations.

c. Passenger Manifest will send to Ground Operation department ([manifest@corendon-airlines.com](mailto:manifest@corendon-airlines.com);  
AYTOP7H)

### **Distribution to**

Original Copy Custom Office,

2<sup>nd</sup> Cabin Crew

3<sup>rd</sup> Station

### **9.4 CARGO MANIFEST**

With the exception of Dangerous Goods, a reasonable quantity cargo carried on Corendon Airlines charter flights, a cargo manifest has to be prepared and NIL to be entered when country regulations require such a manifest. This cargo NIL manifest is requested by costumes authorities. FFM MSG must be sent for the AMS flights.

### **Distribution to**

Original Copy Custom Office,

2<sup>nd</sup> Cabin Crew

3<sup>rd</sup> Station

### **9.5. COUNTRY REGULATION**

Neither Gen-Dec nor passenger manifest are requested for return flights to Turkey. There are passenger and cargo manifest for the different countries. If nothing is shown under gen-dec remarks it is sufficient to state only Commander's name plus number of Cabin and Crew.

## 10. COMPANY DOCUMENTS / FORMS

- Some samples of Corendon Airlines documents have attached to this chapter.
- Please request hard copy of these forms and any handling material from; [groundoperations@corendon-airlines.com](mailto:groundoperations@corendon-airlines.com)
- Handling Partners should follow the stock and inform the Corendon Airlines Ground Operations Department when close to minimums.



## GROUND OPERATION MANUAL

**Doc Code:** CA-GOP-GOM

**Rev No:** 45

**Rev Date:** 01 APR 2026

**Page:** 227

---

UNCONTROLLED COPY

UNCONTROLLED COPY

UNCONTROLLED COPY

UNCONTROLLED COPY

## APPENDIX-1 Form of Indemnity



### FORM OF INDEMNITY

(Please fill the blank areas, 1<sup>st</sup> cop: STATION COPY, 2<sup>nd</sup> copy: PASSENGER, 3<sup>rd</sup> copy: CABIN CHIEF)

Date: \_\_\_\_\_ Flight Number: \_\_\_\_\_  
Passenger Name: \_\_\_\_\_ From / To: \_\_\_\_\_  
Address: \_\_\_\_\_ Telephone: \_\_\_\_\_

Passport Number: \_\_\_\_\_ Prepared By: \_\_\_\_\_

This form and indemnity applies to: (please mark the type of indemnity)

**Pregnancy**

This option should be marked if the passenger is pregnant up to 36 weeks.

**Travel Document Irregularity**

Please explain the details of indemnity

**Other Health Declarations**

Please explain the details of defect/illness

**Other Situations**

Please explain the situation in details

\* I, the undersigned, the above-named passenger / the parent / guardian of the above named Passenger (hereinafter referred to as "Passenger") hereby agree to release and discharge CORENDON AIRLINES INC. (hereinafter referred to as "CAI"), including its agents, officers, and employees from any and all liabilities which may be consequential as the result of the travel and / or carriage by CAI and agree to indemnify and hold CAI harmless from any and all damages and losses sustained by CAI and any and all actions, claims and proceedings against CAI by any third party or parties including all costs, losses, damages, charges and expenses incidental thereto which may be suffered by CAI as the result of the travel and / or carriage by CAI specified above due to conditions specified below and / or any possible consequence thereof.

\* I understand that CAI will not provide any special assistance to the above mentioned passenger(s).

I hereby indemnify and hold harmless CAI and / or other related carriers, their personnel and agents from and against any loss or damage sustained and / or any costs and expenses incurred by them in connection with the above mentioned passenger(s) travel or resulting therefrom and to release them from any and all liability other than as set forth in CAI' General Conditions of Carriage and applicable Tariffs on [corendonairlines.com](http://corendonairlines.com)

Passenger  
Signature: \_\_\_\_\_

Date  
Signed: \_\_\_\_\_

Duty Officer  
Signature: \_\_\_\_\_

Date  
Signed: \_\_\_\_\_



# GROUND OPERATION MANUAL

Doc Code: CA-GOP-GOM

Rev No: 45

Rev Date: 01 APR 2026

Page: 229

## APPENDIX-2 UM Form



### Unaccompanied Minor Acceptance Form

(Please fill all the blank areas, 1<sup>st</sup> copy : STATION COPY, 2<sup>nd</sup> copy : UM Bag, 3<sup>rd</sup> copy : CABIN CHIEF, 4<sup>th</sup> copy : DESTINATION COPY)

#### UM INFORMATIONS

Passenger Name: \_\_\_\_\_ Age / Sex: \_\_\_\_\_  
Date: \_\_\_\_\_ Flight Number: \_\_\_\_\_  
Station: \_\_\_\_\_ From / To: \_\_\_\_\_  
Passport Number: \_\_\_\_\_ Prepared By: \_\_\_\_\_

#### PARENT AT ORIGIN STATION TO ACCOMPANY

Parent Name: \_\_\_\_\_ Relation: \_\_\_\_\_  
Permanent address: \_\_\_\_\_  
Contact Phone: \_\_\_\_\_

Signature: \_\_\_\_\_

I am the parent/guardian of the above mentioned passenger(s) and herewith give him/her permission to travel unaccompanied. I understand that Corendon Airlines will not provide any special assistance to the above mentioned passenger(s).

I hereby indemnify and hold harmless Corendon Airlines and/or other carriers, their personnel and agents from and against any loss or damage sustained and/or any costs and expenses incurred by them in connection with the above mentioned passenger(s) travel or resulting therefrom and to release them from any and all liability other than as set forth in Corendon Airlines' General Conditions of Carriage and applicable Tariffs.

\* I certify the passenger(s) is/are possession of a valid passport(s), health certificate(s) and has any necessary visa(s) for the trip.

#### PARENT AT DESTINATION TO MEET

Parent Name: \_\_\_\_\_ Relation: \_\_\_\_\_  
Permanent address: \_\_\_\_\_  
Contact Phone: \_\_\_\_\_

Signature: \_\_\_\_\_

Duty Officer  
Signature: \_\_\_\_\_ Date Signed: \_\_\_\_\_

Duty Cabin Chief  
Signature: \_\_\_\_\_ Date Signed: \_\_\_\_\_



## APPENDIX-4 Co-Mail Delivery Form:



# CO-MAIL DELIVERY FORM

(Co-mail Teslim Formu)

**FROM:**  
Nereden

**TO:**  
Nereye

**VIA:**  
Bağlantı

**FLIGHT NUMBER / DATE:**  
Uçuş Numarası / Tarih

**CONTENT:**  
İçerik

**QUANTITY:**  
Miktar

**RED NO\*:** ...../20.....-.....  
Kayıt Numarası

**PREPARED BY NAME / SIGN:**  
Teslim Eden

**PREPARED BY NAME / SIGN #1:**  
Teslim Alan 1#

**DLIVERED TO NAME / SIGN #2:**  
Teslim Alan 2#

**DLIVERED TO NAME / SIGN #2:**  
Teslim Alan 3#

Note

- **All parties must keep this form for 3 months.**  
Tüm ilgili şahıslar bu formu 3 ay saklamakla mükelleftir.
- **Please fill all related areas.**  
Lütfen ilgili tüm alanları doldurunuz.
- **\*For the fill REG NO: Department/Year-Trace number of co-mail form Example GOP/2015-001**  
Kayıt numarası için: Departman/Yıl/Co-mail takip numarası Örnek GOP/2015-001



# GROUND OPERATION MANUAL

Doc Code: CA-GOP-GOM

Rev No: 45

Rev Date: 01 APR 2026

Page: 232

## APPENDIX-5 Co-Mail / Co-Mat Forms:



### **\*\*CO - MAIL\*\***

Flt No :  
Dest. :  
Date :  
To :  
Address :

From :  
Name :  
Address :

Contents :  
Pieces and total :

PLS DELIVER TO :



### **\*\*CO - MAT\*\***

Flt No :|  
Dest :  
Date :  
From :  
Name :  
Contents :  
Pieces and total :  
Deliver To :

## APPENDIX-6 Handling Irregularity Report



### Handling Irregularity Report

REPORT NUMBER		REPORTED BY	
DATE		REGISTRATION	
FLIGHT NUMBER		DELAY/MINUTES	..... /..... /..... /..... /.....
STATION OCCURRENCE		FROM	TO
SUPPLIER INVOLVED		STD	STA --
PAX NAME		ATD	ATA --

REMARKS CORENDON AIRLINES/CORENDON DUTCH AIRLINES

REMARKS SUPPLIER	
DATE OF RESPONSE	ANSWERED BY

ROOT CAUSE(S)
<input type="checkbox"/> HUMAN FACTOR <input type="checkbox"/> PROCEDURE(S)/INSTRUCTION(S) <input type="checkbox"/> ENVIRONMENT <input type="checkbox"/> MANAGEMENT <input type="checkbox"/> (ICT) SYSTEM(S) <input type="checkbox"/> EQUIPMENT <input type="checkbox"/> OTHER (please describe root cause) <input type="checkbox"/> <b>ALL NON-COMPLIANCE/DEVIATIONS FOUND HAVE BEEN CORRECTED</b>

CAI: PLEASE SEND THE REPORT BACK WITHIN 3 WORKING DAYS TO GROUNDOPERATIONS@CORENDON-AIRLINES.COM  
 CND: PLEASE SEND THE REPORT BACK WITHIN 3 WORKING DAYS TO DUTYOFFICERAMS@CORENDON.NL

**↓ FOR INTERNAL USE ONLY ↓**

FOR INTERNAL USE ONLY					
CARE PROVIDED (IF GIVEN)	REFRESHMENT		INVOICE DETAILS	SUPPLIER	
	LUNCH/DINNER			QUANTITY	
	DELAY KIT			TOTAL AMOUNT	
	HOTAC			TOTAL ROOMS	
EXTRA REMARKS					

## APPENDIX-7 Baggage Irregularity Information Form:



### BAGGAGE IRREGULARITY INFORMATION

<p><b>Dear Passenger,</b>          First of all, we would like to apologize for any baggage irregularity like damage, delay or loss during a Corendon Airlines flight. This letter has been written in order to inform you about the procedures after the receipt of your Property Irregularity Report (P.I.R.) which you should obtain from the Lost &amp; Found Department before leaving the Passenger Arrival Terminal.</p>	
<p><b>DAMAGED BAGGAGE</b></p> <p>In order to get approval for a refund, please send the requested documents shown below within 7 days by using link; <a href="https://www.corendonairlines.com/lostandfound">https://www.corendonairlines.com/lostandfound</a> to Corendon Airlines Complaints Management Department, Lost and Found Unit:</p> <ul style="list-style-type: none"> <li>*Property Irregularity Report (P.I.R.) of the damaged baggage,</li> <li>*Baggage Tag of the damaged baggage,</li> <li>*Flight Ticket or reservation E-ticket (internet)</li> <li>*Photos of the damaged baggage.</li> </ul>	<p><b>MISSING BAGGAGE</b></p> <p>The Lost &amp; Found Department of the relevant station will immediately start tracing action for your baggage. Should your baggage not be found until your return flight, we suggest you to check again at the Lost &amp; Found Departments of the airports of your departure as well as arrival destinations as some of the baggage cannot be determined because of detached baggage label. If your baggage can still not be found, please send the requested documents shown below by using link; <a href="https://www.corendonairlines.com/lostandfound">https://www.corendonairlines.com/lostandfound</a> to Corendon Airlines Complaints Management Department, Lost and Found Unit:</p> <ul style="list-style-type: none"> <li>*Property Irregularity Report (P.I.R.) of the missing baggage,</li> <li>*Boarding Pass,</li> <li>*Baggage Tag of the lost baggage evidencing baggage weight,</li> <li>*Flight Ticket or reservation E-ticket (internet),</li> </ul>
<p><b>Please note that all of the requested documents and statements have to be presented completely and in English and that Corendon Airlines does not cover the costs of the requested documents.</b></p> <p>Corendon Airlines will not accept responsibility for the damage or loss of protruding parts such as wheels, feet, locks, straps, pull handles, or other items that are attached to baggage, or items lost or damaged as a result of badly packed or over-packed baggage as well as cuts, scratches, scuffs, dents and marks, fragile or perishable items, sports equipment, instruments, items having a special value such as jeweler / money, precious metals, silverware, antiques, heirlooms, computers, electronic devices, samples, medicines, medical items, securities or other valuables, negotiable papers, business documents, passports, other identification documents, baggage accepted under the conditions of the "Limited Release" Tag (LRT), missing, soiled or damaged items within the damaged baggage and items which are not permitted to be carried. We strongly recommend all passengers to obtain adequate travel insurance cover prior to their journey and settle the cases with the insurance company as they are more advantageous.</p> <p>You can get further detailed information about Corendon Airlines conditions at our web-site: <a href="https://www.corendonairlines.com/general-conditions-of-carriage">https://www.corendonairlines.com/general-conditions-of-carriage</a></p> <p>With Kind Regards,          Corendon Airlines          Complaints Management Department / Lost and Found Unit</p>	

## APPENDIX-8 Seat Chart B737-800 / 737-800 MAX:



### Seatplan

Show the passenger-seating layout for the configurations given in the box at the top by inserting the seat row numbers and letters in the following table. For special seats use the description codes listed below.

A = Aisle	N = No smoking
E = Emergency exit	O = Over wing seat
H = Wheel chair	P = Stretcher location
I = Infant preference row / seats	U = Unaccompanied minor
L = Leg space seat	Y = Not fitted

## Seat Chart B737-800 / 737-800 MAX: (cont.)



Seatplan layout (Boeing 737/800 and 737/8 MAX – 189Y)

Section	Row No	ROW LETTER						Max Seats	
		A	B	C		D	E		F
A	1	HINL	NL	NL		Y	Y	Y	3
	2	HINU	NU	ANU		ANL	NL	HINL	6
	3	HINU	NU	ANU		ANU	NU	HINU	6
	4	HIN	N	AN		ANU	NU	HINU	6
	5	HIN	N	AN		AN	N	HIN	6
	6	HIN	N	AN		AN	N	HIN	6
	7	HIN	N	AN		AN	N	HIN	6
	8	HIN	N	AN		AN	N	HIN	6
	9	HIN	N	AN		AN	N	HIN	6
	10	HIN	N	AN		AN	N	HIN	6
	11	HIN	N	AN		AN	N	HIN	6
B	12	HINO	NO	ANO		ANO	NO	HINO	6
	14	HINO	NO	ANO		ANO	NO	HINO	6
	15	HINO	NO	ANO		ANO	NO	HINO	6
	16	ENOL	ENOL	AENOL		AENOL	ENOL	ENOL	6
	17	ENOL	ENOL	AENOL		AENOL	ENOL	ENOL	6
	18	HINO	NO	ANO		ANO	NO	HINO	6
	19	HINO	NO	ANO		ANO	NO	HINO	6
	20	HINO	NO	ANO		ANO	NO	HINO	6
	21	HINO	NO	ANO		ANO	NO	HINO	6
	22	HINO	NO	ANO		ANO	NO	HINO	6
	C	23	HIN	N	AN		AN	N	HIN
24		HIN	N	AN		AN	N	HIN	6
25		HIN	N	AN		AN	N	HIN	6
26		HIN	N	AN		AN	N	HIN	6
27		HIN	N	AN		AN	N	HIN	6
28		HIN	N	AN		AN	N	HIN	6
29		HIN	N	AN		AN	N	HIN	6
30		HIN	N	AN		AN	N	HIN	6
31		HINP	N	AN		AN	N	HIN	6
32		HINP	N	AN		AN	N	HIN	6
33		HINP	N	AN		AN	N	HIN	6



## APPENDIX-10 Loading Instruction Report (All B738 Types)

	Aircraft Type Aircraft Registration:	Date Departure Airport:	/20 Destination Airport:	<b>Load Report / NOTOC</b>	Aircraft Seat Configuration:																																
<b>LOAD SCHEMATIC</b>																																					
<table border="1" style="width:100%; border-collapse: collapse;"> <tr> <td style="text-align: center;">HOLD 4 TOTAL:</td> <td style="text-align: center;">KG</td> <td style="text-align: center;">HOLD 3 TOTAL:</td> <td style="text-align: center;">KG</td> <td style="text-align: center;">HOLD 2 TOTAL:</td> <td style="text-align: center;">KG</td> <td style="text-align: center;">HOLD 1 TOTAL:</td> <td style="text-align: center;">KG</td> </tr> <tr> <td>BAGS</td> <td>PCS</td> <td>BAGS</td> <td>PCS</td> <td>BAGS</td> <td>PCS</td> <td>BAGS</td> <td>PCS</td> </tr> <tr> <td>CARGO</td> <td>PCS</td> <td>CARGO</td> <td>PCS</td> <td>CARGO</td> <td>PCS</td> <td>CARGO</td> <td>PCS</td> </tr> <tr> <td>OTHER</td> <td></td> <td>OTHER</td> <td></td> <td>OTHER</td> <td></td> <td>OTHER</td> <td></td> </tr> </table>		HOLD 4 TOTAL:	KG	HOLD 3 TOTAL:	KG	HOLD 2 TOTAL:	KG	HOLD 1 TOTAL:	KG	BAGS	PCS	BAGS	PCS	BAGS	PCS	BAGS	PCS	CARGO	PCS	CARGO	PCS	CARGO	PCS	CARGO	PCS	OTHER		OTHER		OTHER		OTHER					
HOLD 4 TOTAL:	KG	HOLD 3 TOTAL:	KG	HOLD 2 TOTAL:	KG	HOLD 1 TOTAL:	KG																														
BAGS	PCS	BAGS	PCS	BAGS	PCS	BAGS	PCS																														
CARGO	PCS	CARGO	PCS	CARGO	PCS	CARGO	PCS																														
OTHER		OTHER		OTHER		OTHER																															
WHEEL CHAIRS, BUGGIES, any TRANSIT LOAD and any other info related to HOLDS should be noted in 'OTHER'																																					
<p><b>LOADING INSTRUCTIONS</b></p> <p><b>Standard loading two-sector flights</b></p> <ul style="list-style-type: none"> <li>- 1/3 of total load (in pieces) in hold 2, if rest in hold 1;</li> <li>- 2/3 of total load (in pieces) in hold 3 of which 1/3 PCS in hold 4</li> <li>- Manual wheelchairs and buggies in hold 4 then 3;</li> <li>- Priority/labeled baggage in hold 4</li> <li>- Loading sequence: Loading should start from hold 2, then 1, then 3 and then 4 in sequence.</li> </ul> <p><b>Standard loading three sector flights</b></p> <ul style="list-style-type: none"> <li>- Distribute baggage and cargo evenly over the holds;</li> <li>- Loading to be started from forward hold to aft hold</li> <li>- Baggage of heaviest leg in hold 3, if rest in hold 4;</li> <li>- Baggage of lightest leg in hold 2, if rest in hold 1;</li> <li>- First load Hold 2 and then 3;</li> </ul>																																					
<p><b>SUPPLEMENTARY INFORMATION</b></p> <p>NOTOC: <input type="checkbox"/> YES <input type="checkbox"/> NO (YES, separate NOTOC should be provided)</p>																																					
<p><b>Additional Info/remarks loading supervisor</b></p> <p>1. All holds were empty or contained only valid transit baggage before commencement of loading</p> <p>2. All holds have been unloaded and checked in accordance with the Load Schematic above</p> <p>3. There are no evidence that any damaged or leaking baggage have been loaded on this aircraft</p> <p style="text-align: right;">Load Supervision/Remarks Signature: _____</p>																																					
<b>DOCUMENT ACCEPTANCE</b>																																					
<p>The Commander confirms that the aircraft has been completed according to the items in Corendon Airlines OMM 14-10.01, at time:</p> <p>- The Commander is satisfied that the Mass &amp; Balance is correct:</p> <p>- Commander Name and Signature (or Document Acceptance): _____</p> <p>- Masses + CG checked with envelope: _____</p> <p style="text-align: right;">Commander's Name and Signature: _____</p>																																					
<p>CA-LORD REPORT</p> <p style="text-align: right;">Yellow Copy: Handling of Departure Station</p> <p style="text-align: right;">Pink Copy: Handling of Destination</p> <p style="text-align: right;">White Copy: Flight Envelope</p>																																					

REV 01/25-01-2009

**APPENDIX-11 IATA DGR Table 2.3A**

**TABLE 2.3.A**  
**Provisions for Dangerous Goods Carried by Passengers or Crew**  
**(Subsection 2.3)**

*Dangerous goods must not be carried in or as passengers or crew, checked or carry-on baggage, except as otherwise provided below. Dangerous goods permitted in carry-on baggage are also permitted "on one's person", except where otherwise specified.*

	The pilot-in-command must be informed of the location			
	Permitted in or as carry-on baggage			
	Permitted in or as checked baggage		The approval of the operator is required	
Alcoholic beverages, when in retail packagings, containing more than 24% but not more than 70% alcohol by volume, in receptacles not exceeding 5 L, with a total net quantity per person of 5 L.	NO	YES	YES	NO
<b>Note:</b> Alcoholic beverages containing 24% or less alcohol by volume are not subject to any restrictions.				
<b>Ammunition, securely packaged</b> (in Div. 1.4S, UN 0012 or UN 0014 only), in quantities not exceeding 5 kg gross weight per person for that person's own use. Allowances for more than one person must not be combined into one or more packages.	YES	YES	NO	NO
<b>Avalanche rescue backpack</b> , one (1) per person, containing cartridges of compressed gas in Div. 2.2. May also be equipped with a pyrotechnic trigger mechanism containing no more than 200 mg net of Div. 1.4S. The backpack must be packed in such a manner that it cannot be accidentally activated. The airbags within the backpacks must be fitted with pressure relief valves.	YES	YES	YES	NO
<b>Baggage with installed lithium batteries</b> non-removable batteries exceeding 0.3 g lithium metal or 2.7 Wh.		FORBIDDEN		
<b>Baggage with installed lithium batteries:</b>				
– non-removable batteries. Batteries must contain no more than 0.3 g lithium metal or for lithium ion must not exceed 2.7 Wh;	NO	YES	YES	NO
– removable batteries. Batteries must be removed if baggage is to be checked in. Removed batteries must be carried in the cabin.				
<b>Batteries, spare/loose</b> , including lithium batteries, non-spillable batteries, nickel-metal hydride batteries and dry batteries (see 2.3.5.8) for portable electronic devices must be carried in carry-on baggage only. Articles which have the primary purpose as a power source, e.g. power banks are considered as spare batteries. These batteries must be individually protected to prevent short circuits. Lithium metal batteries: the lithium metal content must not exceed 2 g (see 2.3.5.8.4). Lithium ion batteries: the Watt-hour rating must not exceed 100 Wh (see 2.3.5.8.4). Each person is limited to a maximum of 20 spare batteries. *The operator may approve the carriage of more than 20 batteries. Non-spillable batteries: must be 12 V or less and 100 Wh or less. Each person is limited to a maximum of 2 spare batteries (see 2.3.5.8.5).	NO*	NO	YES	NO
<b>Camping stoves and fuel containers that have contained a flammable liquid fuel</b> , with empty fuel tank and/or fuel container (see 2.3.2.5 for details).	YES	YES	NO	NO
<b>Chemical Agent Monitoring Equipment</b> , when carried by staff members of the Organization for the Prohibition of Chemical Weapons on official travel (see 2.3.4.4).	YES	YES	YES	NO
<b>Disabling devices</b> such as mace, pepper spray, etc. containing an irritant or incapacitating substance are forbidden on the person, in checked and carry-on baggage.		FORBIDDEN		
<b>Dry ice (carbon dioxide, solid)</b> , in quantities not exceeding 2.5 kg per person when used to pack perishables not subject to these Regulations in checked or carry-on baggage, provided the baggage (package) permits the release of carbon dioxide gas. Checked baggage must be marked "dry ice" or "carbon dioxide, solid" and with the net weight of dry ice or an indication that there is 2.5 kg or less dry ice.	YES	YES	YES	NO
<b>e-cigarettes</b> (including e-cigars, e-pipes, other personal vaporizers) containing batteries must be individually protected to prevent accidental activation (see 2.3.5.8.2).	NO	NO	YES	NO
<b>Electro shock weapons</b> (e.g. Tasers) containing dangerous goods such as explosives, compressed gases, lithium batteries, etc. are forbidden in carry-on baggage or checked baggage or on the person.		FORBIDDEN		
<b>Fuel cells</b> containing fuel, powering portable electronic devices (e.g. cameras, cellular phones, laptop computers and camcorders), see 2.3.5.9 for details.	NO	NO	YES	NO
<b>Fuel cell cartridges, spare</b> for portable electronic devices, see 2.3.5.9 for details.	NO	YES	YES	NO
<b>Gas cartridges, small, non-flammable</b> containing carbon dioxide or other suitable gas in Division 2.2. Up to two (2) small cartridges fitted into a self-inflating personal safety device, intended to be worn by a person, such as a life jacket or vest. Not more than two (2) devices per passenger and up to two (2) spare small cartridges per device, for other devices not more than four (4) cartridges up to 50 mL water capacity. (see 2.3.4.2).	YES	YES	YES	NO
<b>Gas cylinders, non-flammable, non-toxic</b> worn for the operation of mechanical limbs. Also, spare cylinders of a similar size if required to ensure an adequate supply for the duration of the journey.	NO	YES	YES	NO
<b>Hair styling equipment containing a hydrocarbon gas cartridge</b> , up to one (1) per passenger or crew-member, provided that the safety cover is securely fitted over the heating element. This hair styling equipment must not be used on board the aircraft. Spare gas cartridges for such hair styling equipment are not permitted in checked or carry-on baggage.	NO	YES	YES	NO

**IATA DGR Table 2.3A(cont.)**

**TABLE 2.3.A**  
**Provisions for Dangerous Goods Carried by Passengers or Crew**  
**(Subsection 2.3) (continued)**

The pilot-in-command must be informed of the location				
Permitted in or as carry-on baggage				
Permitted in or as checked baggage				
The approval of the operator is required				
Insulated packagings containing refrigerated liquid nitrogen (dry shipper), fully absorbed in a porous material containing only non-dangerous goods.	NO	YES	YES	NO
Internal combustion or fuel cell engines, must meet A70 (see 2.3.5.12 for details).	NO	YES	NO	NO
△ Lithium Batteries: Portable electronic devices (PED) containing lithium metal or lithium ion cells or batteries, including medical devices such as portable oxygen concentrators (POC) and consumer electronics such as cameras, mobile phones, laptops and tablets (see 2.3.5.8). For lithium metal batteries the lithium metal content must not exceed 2 g and for lithium ion batteries the Watt-hour rating must not exceed 100 Wh. Devices must be protected from damage and inadvertent activation. Those in checked baggage must be completely switched off. Each person is limited to a maximum of 15 PED. *The operator may approve the carriage of more than 15 PED.	NO*	YES	YES	NO
Lithium batteries, spare/loose, including power banks, see Batteries, spare/loose				
△ Lithium battery-powered electronic devices. Lithium ion batteries for portable (including medical) electronic devices, a Wh rating exceeding 100 Wh but not exceeding 160 Wh. For portable medical electronic devices only, lithium metal batteries with a lithium metal content exceeding 2 g but not exceeding 8 g. Devices must be protected from damage. Devices in checked baggage must be completely switched off.	YES	YES	YES	NO
Lithium batteries, spare/loose with a Watt-hour rating exceeding 100 Wh but not exceeding 160 Wh for consumer electronic devices and PMED or with a lithium metal content exceeding 2 g but not exceeding 8 g for PMED only. Maximum of two spare batteries in carry-on baggage only. These batteries must be individually protected to prevent short circuits.	YES	NO	YES	NO
Matches, safety (one small packet) or a small cigarette lighter that does not contain unabsorbed liquid fuel, other than liquefied gas, intended for use by an individual when carried on the person. Lighter fuel and lighter refills are not permitted on one's person or in checked or carry-on baggage.	NO	ON ONE'S PERSON		NO
Note: "Strike anywhere" matches, "Blue flame" or "Cigar" lighters or lighters powered by a lithium battery without a safety cap or means of protection against unintentional activation are forbidden (see 2.3.5.8.4(e)).				
Mobility Aids: Battery-powered wheelchairs or other similar mobility devices with non-spillable wet batteries, nickel-metal hydride batteries or dry batteries, (see 2.3.2.2).	YES	YES	NO	YES
Mobility Aids: Battery-powered wheelchairs or other similar mobility devices with spillable batteries or with lithium ion batteries (see 2.3.2.3 and 2.3.2.4 for details).	YES	YES	NO	YES
Mobility Aids: Battery-powered wheelchairs or other similar mobility devices with lithium ion batteries where the design of the mobility aid does not provide adequate protection for the battery(ies) (see 2.3.2.4.3 for details).	YES	NO	YES	YES
Non-radioactive medicinal or toiletry articles (including aerosols) such as hair sprays, perfumes, colognes and medicines containing alcohol; and Non-flammable, non-toxic (Division 2.2) aerosols, with no subsidiary hazard, for sporting or home use (see 2.3.5.1).	NO	YES	YES	NO
The total net quantity of non-radioactive medicinal or toiletry articles and non-flammable, non-toxic (Division 2.2) aerosols must not exceed 2 kg or 2 L and the net quantity of each single article must not exceed 0.5 kg or 0.5 L. Release valves on aerosols must be protected by a cap or other suitable means to prevent inadvertent release of the contents.				
Oxygen or air, gaseous, cylinders required for medical use. The cylinder must not exceed 5 kg gross weight.	YES	YES	YES	YES
Note: Liquid oxygen systems are forbidden for transport.				
Permeation devices, must meet A41 (see 2.3.5.13 for details).	NO	YES	NO	NO
Radioisotopic cardiac pacemakers or other devices, including those powered by lithium batteries, implanted into a person or fitted externally.	NO	ON ONE'S PERSON		NO
Security-type equipment (see 2.3.2.6 for details).	YES	YES	NO	NO
Security-type attaché cases, cash boxes, cash bags, etc. incorporating dangerous goods, such as lithium batteries and/or pyrotechnic material, except as provided in 2.3.2.6 are totally forbidden. See entry in 4.2-List of Dangerous Goods.		FORBIDDEN		
Specimens, non-infectious packed with small quantities of flammable liquid, must meet A180 (see 2.3.5.11 for details).	NO	YES	YES	NO
Thermometer, medical or clinical, which contains mercury, one (1) per person for personal use, when in its protective case.	NO	YES	NO	NO
Thermometer or barometer, mercury filled carried by a representative of a government weather bureau or similar official agency (see 2.3.3.1 for details).	YES	NO	YES	YES

**Note:**  
 The provisions of Subsection 2.3 and Table 2.3.A may be limited by State or operator variations. Passengers should check with their airline for the current provisions.

## APPENDIX-12 Pre-Departure Table

### 4.6.3.2 Predeparture Table

Prior to aircraft movement, the responsible ground staff member (headset operator) shall ascertain that the following requirements are met/carried out:

Legend
TWT–towbar tractor
TWL–towbarless tractor

ACTION	APPLICABLE TO				
	PUSHBACK		TOWING		TAXI OUT
	TWT	TWL	TWT	TWL	
The required pre-departure servicing checks are completed.	✓	✓	✓	✓	✓
Fire protection devices are available and correctly positioned (as per local rules).	✓	✓	✓	✓	✓
The tractor and towbar combination, if applicable, are suitable for the operation, considering the aircraft type and weight as well as weather and surface conditions.	✓	✓	✓	✓	
The nose gear steering bypass pin is installed correctly, or the nose gear steering torque links are disconnected, if applicable, or the nose gear steering mechanisms are set as required for pushback (as applicable to the aircraft type).	✓	✓	✓	✓	
Communication with flight crew/brake operator and responsible ground staff member is established via an interphone system.	✓	✓	✓	✓	✓
Aircraft main landing gear (MLG) chocks are installed, and nose gear chocks are removed, if applicable.	✓	✓	✓	✓	
Aircraft nose gear chocks are installed and MLG chocks removed, if applicable.					
Additional personnel, such as wing walkers, are present, if applicable/required.	✓	✓	✓	✓	
If an air start unit (ASU) is required, check the equipment is correctly positioned and suitable for the operation.	✓	✓			
If an ASU engine start is undertaken, communicate to confirm ASU positioning and engine start sequence with the flight crew.	✓	✓			
All persons not involved in the aircraft departure operation are clear of the departing aircraft, outside the ERA, and remain clear of the aircraft and pushback equipment throughout the pushback maneuver.	✓	✓	✓	✓	✓
The GSE is parked in designated locations outside the ERA, and the intended path of the aircraft remains clear of equipment and other obstacles throughout the pushback maneuver.	✓	✓	✓	✓	✓
The PBB is fully retracted and parked in its designated parking location, if applicable.	✓	✓	✓	✓	✓
The ERA and the path/area that the aircraft will move toward is clear of FOD, and remains so throughout the pushback maneuver, ensuring safe aircraft movement.	✓	✓	✓	✓	✓
The stand surface condition is sufficiently free of ice, snow, etc., to ensure safe aircraft movement.	✓	✓	✓	✓	✓
The ramp area is free of objects/obstacles that may be impacted by the aircraft or may endanger others due to jet blast effects.	✓	✓	✓	✓	✓

## Pre-Departure Table (cont.)

ACTION	APPLICABLE TO				
	PUSHBACK		TOWING		TAXI OUT
	TWT	TWL	TWT	TWL	
The air intake and blast areas of the aircraft engines are clear of persons and obstacles, such as GSE.	✓	✓			
All persons involved in the aircraft movement stay well clear of the danger areas around the tractor, landing gear and aircraft engines.	✓	✓	✓	✓	
Flight crew/brake operator confirm that the aircraft parking brake is set.	✓	✓	✓	✓	
Completion of the predeparture table is indicated to the flight crew.	✓	✓	✓	✓	
A qualified brake operator is in the cockpit, where required by operating airline procedures.			✓	✓	
Cross-reference with IGOM	4.6.4.2	4.6.4.3			

**Note:** Where a remote-controlled pushback tractor connected to the nose gear is used, TWL predeparture activities shall apply.



**Danger:**

It is critical that the responsible ground staff member (headset operator) establishes verbal communication with the flight crew via the aircraft interphone system, as departures using marshalling hand signals without headset communication shall only be conducted in exceptional cases.

**APPENDIX-13 On the Job Training Form**

<b>CORENDON HAVAYOLLARI YER İŞLETME DEPARTMANI İŞ BAŞI EĞİTİM KONTROL LİSTESİ</b>					
İSİM - SOYİSİM :		Değerlendirme Ölçeği:			
ÜNVAN :		• 1 Çok Uygun			
TARİH :		• 2 Uygun			
		• 3 Orta			
		• 4 Uygun Değil			
KONTROL SORULARI	1	2	3	4	Ek Bilgi
<b>GENEL (Lütfen en uygun olanı (X) ile işaretleyiniz.)</b>					
1	İşe zamanında geliyor mu? Görev tanımını biliyor mu?				
2	Üniforma kullanımı şirket yönetmeliklerine uygun mu?				
3	Şirket yönetmelikleri, misyon&vizyon hakkında bilgi sahibi mi?				
4	SMS hakkında temel bilgi sahibi mi?				
5	Security hakkında temel bilgi sahibi mi?				
6	Mesai arkadaşları ile uyum içinde çalışıyor mu?				
7	Diğer birimlerle iletişim ve işbirliği kurabiliyor mu?				
8	Şirket dokümanlarına ulaşımında yeterlilik sahibi mi?				
9	Haftalık Ticari Uçuş Tarifesinin dağıtımı konusunda bilgi sahibi mi?				
10	Gecikmeler, gecikme kodları, prosedürleri ve gecikme durumunda bilgilendirilecek birimler hakkında bilgi sahibi mi?				
11	Yolcu hakları hakkında bilgi sahibi mi?				
12	HIR raporları doldurulması ve raporların ilgili birimlerle paylaşılması konusunda bilgi sahibi mi?				
13	Şirketin comat-comail-EIC-CSU vb. gönderileri/prosedürleri hakkında temel bilgi sahibi mi?				

**On the Job Training Form (cont.)****CHECK IN (Lütfen en uygun olanı (X) ile işaretleyiniz.)**

14	Check-in öncesi check-in personeli ile briefing yapıyor mu?				
15	Yolcuyu (varsa) gecikme v.b. özel durumlar ile ilgili bilgilendiriyor mu?				
16	Özel yolcu mesajlarının handling tarafından gönderildiği kontrol ediliyor mu?				
17	PNL hazırlama/gönderme/yükleme hakkında bilgi sahibi mi?				
18	Yolcu sayılarının hazırlanması ve yayınlanması konusunda bilgi sahibi mi?				
19	CASAB sistemine hakim mi?				
20	Acil Durumda CASAB sisteminden PNL çekebiliyor mu?				
21	CASAB sisteminden uçuşları kontrol edebiliyor mu?				
22	CASAB sistemi Rezervasyon sayfası hakkında bilgi sahibi mi?				
23	CASAB sistemi Admin sayfası hakkında bilgi sahibi mi?				
24	Flycorendon.com Web-checkin, bagaj satın alma ve kontuarda satılan hizmetler hakkında genel bilgi sahibi mi?				
25	APIS konusuna hakim mi?				
26	APIS iletişim bilgileri hakkında bilgi sahibi mi?				
27	Yaygın kullanılan DCS sistemleri hakkında yeterli bilgi sahibi mi?				
28	Acente talepleri hakkında genel bilgi sahibi mi?				
29	Acente taleplerinin kaydedilmesi ve saklanması konusunda bilgi sahibi mi?				
30	Acente taleplerinin gönderimi hakkında bilgi sahibi mi?				
31	Genel taşıma koşulları ve Quick Reference hakkında bilgi sahibi mi?				
32	INAD-DEPO-DEPU yolcular hakkında genel bilgi sahibi mi?				
33	Unruly yolcular hakkında genel bilgi sahibi mi?				

**On the Job Training Form (cont.)**

<b>RAMP / OPERASYON (Lütfen en uygun olanı (X) ile işaretleyiniz.)</b>					
34	Ekipmanların uçak altında prosedürlere uygun olarak kullanımını ve park edilmesinin kontrolünü yapıyor mu?				
35	Zamanında Push-Back hazırlığının yapılmasını ve towcar aracının uçağa bağlanmasını sağlıyor mu?				
36	Günlük uçuş takip formunu doldurabiliyor mu?				
37	MVT, LDM, SOM vb. Mesajlarını okuyabiliyor mu?				
38	Handling görevlisi ile briefing yapıp gerekli bilgi alışverişini sağlıyor mu?				
39	Uçuş ekibi ile briefing yapıp gerekli bilgi alışverişini sağlıyor mu?				
40	Uçak park pozisyonundaki gerekli teçhizatlar kontrol ediliyor mu?				
41	Tedarikçilerin zamanında uçak başında olması sağlanıyor mu?				
42	Ekipmanlar yanaşma kurallarına uyuyor mu?				
43	Uçak çevresi işaretçileri/duba/takozlar uygun pozisyonunda mı?				
44	Uçak park pozisyonunda emniyette mi?				
45	Uçak gövde kontrolü yapıldı mı?Hasar tespit edildi ise gerekli birimlere bilgilendirme yapıyor mu?				
46	FOD kontrolü yapılıyor mu?				
47	Departure and security check yapılıyor mu?				
48	Ambar içi ağırların örülü olduğu kontrol ediliyor mu?				
49	Uçuş plan saati, meydan ve güzergah slotları (CTOT) hakkında temel bilgi sahibi mi?				
50	Uçak temizliği ve denetlenmesi hakkında bilgi sahibi mi?				
51	İkram konusunda temel bilgi sahibi mi?				
52	Yakıt alımı ve prosedürleri hakkında temel bilgi sahibi mi?				
53	Pushback-towing operasyonları hakkında yeterlilik sahibi mi?				

**On the Job Training Form (cont.)**

54	Genel boarding prosedürleri ve sistemleri hakkında bilgi sahibi mi?				
55	Boarding zamanlaması hakkında yeterlilik sahibi mi?				
56	Row by row prosedürleri hakkında bilgi sahibi mi?				
57	Yük ve denge hakkında temel bilgilere sahip mi?				
58	Yük ve denge evrakları hakkında temel bilgilere sahip mi?				
59	Gümrük mevzuatı hakkında genel bilgilere sahip mi?				
<b><u>KARGO (Lütfen en uygun olanı (X) ile işaretleyiniz.)</u></b>					
60	Konşimento okumasını biliyor mu? (Kap, kilo, kargo cinsi, alıcı/gönderici, acenta ismi hanesi, chargeable weight hanesi)				
61	Kargo kabul koşulları hakkında temel bilgi sahibi mi?				
62	Taşınması yasak maddeler hakkında bilgi sahibi mi?				
63	Kargo mesajları okuyabiliyor mu? FFM,FWB,FAK vb.				
64	AWB ve benzeri kargo evraklarına hakim mi?				
65	Gelen-Giden kargoyu Kargo Takip Dosyasına işleyebiliyor mu?				
<b>Değerlendirme Yapılan Uçuşlar :</b>					
CAI...../..... / Not:					
CAI...../..... / Not:					
CAI...../..... / Not:					
<b>Değerlendirme Sonucu :</b> *Sonucu daire içine alınız. 1 / 2 / 3 / 4 Değerlendirmeyi Yapan :1					
İmza :			Onaylayan :		
Tarih :					

**APPENDIX-14 Weapon Delivery Form****SİLAH TESLİM TUTANAĞI  
WEAPON DELIVERY FORM**

UÇUŞ / FLIGHT	YOLCU / PASSENGER	SİLAH TİPİ / TYPE OF WEAPON
Sefer No /Flight No	Adi-Soyadi / Name-Surname	Marka/Brand Name
Tarih/Date	Doğum Tarihi Ve Yeri/Date-Place Of Birth	Seri No/Serial No
Saat/Time	Silahin Verildiği Yer / Place Of Issuing Weapon	Çap/Calibre
Çıkış Havaalanı / Departure Airport	Yolcunun Mesleği/Passenger's Occupation	Etiket No/Tag Id
Varış Havaalanı / Arrival Airport	Telefon Numarası / Phone Number Imza/Signature	Ek malz./Add Equipment
<b>Teslim Alan Emniyet Yetkilisinin Adı Soyadı Name-Surname Of Receiving Authority</b>  ETİKET NO/ TAG NO  Imza/Signature	<b>Handling Personelinin Adı Soyadı / Name of Handling Agent</b>  Ünvanı/Title  Imza/Signature	
<b>Tutanağı Teslim Alan Ekip Adı Soyadı / Name-Surname Of Crew Receiving Form</b>  Signature	<b>Uçağın İnşinde Teslim Alan Yetkilinin Adı Soyadı/ Name-Surname Of Authorized Person Upon Arrival</b>  Ünvan/Title  Imza/Signature	

**APPENDIX-15 Weapon NOTOC Form****WEAPON NOTOC FORM  
(FOR LAW ENFORCEMENT)**

UÇUŞ / FLIGHT	KOLLUK/ LAW ENCFORMENT OFFICER
SEFER NO / FLIGHT NO	ADI-SOYADI / NAME-SURNAME
TARİH/DATE	DOĞUM TARİHI VE YERİ/DATE-PLACE OF BIRTH
SAAT/TIME	KOLTUK NUMARASI / PLACE OF ISSUING WEAPON
UCUS GUZARGAHI / FLIGHT ROUTE	PAASPORT NUMBER - NATIONALITY

I state that I know the risks of using a weapon inside an aircraft, and I accept and will respect the following measures:

- declare my service weapon to the aircraft operator;
- unload the weapon of all ammunition in the presence of an aircraft operator representative;
- place the ammunition in an appropriate container;
- keep ammunition concealed at all times;
- place the weapon in a security envelope to be given to the pilot-in-command and stored under his or her authority; and
- be presented to the pilot-in-command by an aircraft operator representative

Name, stamp and signature of law enforcement agency

Kuruluş Yetkilisi isim, mühür ve imzası

Signature of law enforcement officer

Koruma Görevlisinin imzası

Sorumlu Kaptanın İsmi ve İmzası

Name&Signature of the PIC

1.Copy: PIC

2.Copy: Ground Handling Co. / Private Security Co. at Departing Station

3.Copy: Security Department

Note: Bu form her bir yetkili için hazırlanmalıdır.

Note: This form must be prepared for each Law Enforcement Officers

## APPENDIX-16 Sample NOTOC form

SPECIAL LOAD - NOTIFICATION TO CAPTAIN														
Station of Loading			Flight Number		Date		Aircraft Registration		Prepared By					
<b>DANGEROUS GOODS</b>														
Station of Unloading	Air Way bill Number	Proper Shipping Name	UN or ID Number	Class or Division	Sub Hazard	Number of Packages	Net Quantity or Transp. Ind per package	Radio-active Material Category	Packing Group	IMP Code	CAO (x)	ERG CODE	Loaded ULD ID	Position Compt
<b>OTHER SPECIAL LOAD</b>														
Station of Unloading	Air Way Bill Number	Contents and Description		Number of Packages	Quantity	Supplementary/Information		LOADED ULD ID		CPT/ POS				
There is no evidence that any damaged or leaking packages containing dangerous goods have been loaded on the aircraft.		CAPTAIN'S SIGNATURE		EMERGENCY PHONE										
LOADING SUPERVISOR'S SIGNATURE														
Distribution : (1) Aircraft Captain (original) (2) Load sheet Ship's Satchel (1st copy) (3) Station File (2nd Copy)														

**APPENDIX-17 Passenger Irregularity Form**



**PASSENGER IRREGULARITY FORM**

FLIGHT DETAILS	
Flight Number:	
Route:	
A/C Registration:	

OVERBOOKED PASSENGERS	
Has the refreshment service been provided?	YES <input type="checkbox"/> NO <input type="checkbox"/>
Please specify the amount of refreshment	
Has the transportation service been provided?	YES <input type="checkbox"/> NO <input type="checkbox"/>
Has the accommodation service been provided?	YES <input type="checkbox"/> NO <input type="checkbox"/>
Who purchased the new ticket?	CORENDON <input type="checkbox"/> PAX <input type="checkbox"/> HANDLING <input type="checkbox"/>
Please specify the names of the passengers:	

DENIED PASSENGERS	
Where the passengers are denied?	CHECK-IN <input type="checkbox"/> GATE <input type="checkbox"/>
What the reason of denied?	
Please specify the names of the passengers:	

OTHER REMARKS:
Specified details of irregularities and actions taken regarding e.g.: Refused passengers, giving full reason for denied check-in / boarding), booking errors, any incident concerning flight safety, passengers showing up at check-in after deadline (giving full passengers details and times), PRM booking figures discrepancies, DCS issues:

Prepared by:
--------------

Please kindly share this report with: [groundoperations@corendon-airlines.com](mailto:groundoperations@corendon-airlines.com)

## APPENDIX-18 Boarding Announcement

 <b>BOARDING ANNOUNCEMENT - BY ROWS/ZONES</b>										
STEPS	AIRBRIDGE									
<p>Ladies and gentlemen,</p> <p><b>We would like to bring to your attention that today's departure are operated by ....(wetlease operator's name)</b></p> <p>Corendon Airlines flight XC/XR (...) to (...) will shortly be available for boarding through gate(...).</p> <p>We will prioritize passengers with infants and passengers with reduced mobility.</p> <p>They are requested to come to the gate now.</p> <p>For other passengers, please remain seated for the time being, as to reduce congestion we will be boarding by seat number/ZONE, which can be found on your boarding pass.</p>										
BOARDING GROUP CODES MUST BE STRICTLY ENFORCED; AVOID QUEUING ON THE STEPS / AIRBRIDGE										
<b>FIRST GROUP</b>	<p>Ladies and gentlemen, Corendon Airlines flight XC/XR (...) to (...) we would firstly like to invite passengers in rows/ZONE (...)</p> <table border="1" style="margin: 10px auto; border-collapse: collapse;"> <thead> <tr> <th style="font-size: 8px;">A/C Type</th> <th style="font-size: 8px;">Row Numbers</th> <th style="font-size: 8px;">Zone</th> </tr> </thead> <tbody> <tr> <td style="font-size: 8px;">B737-800</td> <td style="font-size: 8px;">11--23</td> <td style="font-size: 8px;">B</td> </tr> <tr> <td style="font-size: 8px;">A320</td> <td style="font-size: 8px;">11--20</td> <td style="font-size: 8px;">B</td> </tr> </tbody> </table> <p style="text-align: center;">to come forward to gate (...).</p> <p>Please have your boarding pass and passport open ready for inspection and mind the gap as you board the aircraft. Thank you for travelling with Corendon Airlines and have a lovely holiday / flight!</p>	A/C Type	Row Numbers	Zone	B737-800	11--23	B	A320	11--20	B
A/C Type	Row Numbers	Zone								
B737-800	11--23	B								
A320	11--20	B								
<b>FIRST GROUP</b>	<p>Ladies and gentlemen, Corendon Airlines flight XC/XR (...) to (...) we would firstly like to invite passengers in rows/ZONE (...)</p> <table border="1" style="margin: 10px auto; border-collapse: collapse;"> <thead> <tr> <th style="font-size: 8px;">A/C Type</th> <th style="font-size: 8px;">Row Numbers</th> <th style="font-size: 8px;">Zone</th> </tr> </thead> <tbody> <tr> <td style="font-size: 8px;">B737-800</td> <td style="font-size: 8px;">23--33</td> <td style="font-size: 8px;">C</td> </tr> <tr> <td style="font-size: 8px;">A320</td> <td style="font-size: 8px;">21--30</td> <td style="font-size: 8px;">C</td> </tr> </tbody> </table> <p style="text-align: center;">to come forward to gate (...).</p> <p>Please have your boarding pass and passport open ready for inspection and mind the gap as you board the aircraft. Thank you for travelling with Corendon Airlines and have a lovely holiday / flight!</p>	A/C Type	Row Numbers	Zone	B737-800	23--33	C	A320	21--30	C
A/C Type	Row Numbers	Zone								
B737-800	23--33	C								
A320	21--30	C								
ENSURE NO QUEUES - WAIT TWO MINUTES TO ALLOW CUSTOMERS TO BOARD AND SETTLE										
<b>SECOND GROUP</b>	<p>Ladies and gentlemen, thank you for waiting.</p> <p>We would now like to invite all remaining passengers for Corendon Airlines flight XC/XR (...) to (...) to come forward for boarding through gate (...).</p> <p>Please have your boarding pass and passport open ready for inspection and mind the gap as you board the aircraft. Thank you for travelling with Corendon Airlines and have a lovely holiday / flight!</p>									
<b>SECOND GROUP</b>	<p>Ladies and gentlemen, Corendon Airlines flight XC/XR (...) to (...) is currently boarding, and we would now like to invite passengers in rows/ZONE (...)</p> <table border="1" style="margin: 10px auto; border-collapse: collapse;"> <thead> <tr> <th style="font-size: 8px;">A/C Type</th> <th style="font-size: 8px;">Row Numbers</th> <th style="font-size: 8px;">Zone</th> </tr> </thead> <tbody> <tr> <td style="font-size: 8px;">B737-800</td> <td style="font-size: 8px;">12--33</td> <td style="font-size: 8px;">B-C</td> </tr> <tr> <td style="font-size: 8px;">A320</td> <td style="font-size: 8px;">11--30</td> <td style="font-size: 8px;">B-C</td> </tr> </tbody> </table> <p style="text-align: center;">to come forward to gate (...). Please have your boarding pass and passport open ready for inspection and mind the gap as you board the aircraft.</p> <p>Thank you for travelling with Corendon Airlines and have a lovely holiday / flight !</p>	A/C Type	Row Numbers	Zone	B737-800	12--33	B-C	A320	11--30	B-C
A/C Type	Row Numbers	Zone								
B737-800	12--33	B-C								
A320	11--30	B-C								
ENSURE NO QUEUES - WAIT TWO MINUTES TO ALLOW CUSTOMERS TO BOARD AND SETTLE										
<b>THIRD GROUP</b>	<p>Ladies and gentlemen, thank you for waiting.</p> <p>We would now like to invite all remaining passengers for Corendon Airlines flight XC/XR (...) to (...) to come forward for boarding through gate (...).</p> <p>Please have your boarding pass and passport open ready for inspection and mind the gap as you board the aircraft. Thank you for travelling with Corendon Airlines and have a lovely holiday / flight!</p>									
<b>THIRD GROUP</b>	<p>Ladies and gentlemen, thank you for waiting.</p> <p>We would now like to invite all remaining passengers for Corendon Airlines flight XC/XR (...) to (...) to come forward for boarding through gate (...).</p> <p>Please have your boarding pass and passport open ready for inspection and mind the gap as you board the aircraft. Thank you for travelling with Corendon Airlines and have a lovely holiday / flight!</p>									

## 11 AIR PASSENGER RIGHTS

The rules say that passengers are entitled to receive compensation for problems with air travel. If the flight is overbooked or cancelled, the passenger is entitled to financial compensation. Airlines are always obliged to offer assistance.

### 11.1 Check in and Boarding Procedure – General

Before check-in starts the responsible person on duty should make sure that all relevant and all the required check-in material is available, such as:

- Air Passenger Rights Placard on Turkish and European Flights.
- Air Passenger Rights leaflets.

Place the Air passenger rights signage at boarding gates or keep the Air Passenger Right brochure on hand and deliver it to the passenger when requested.

### 11.2 Information to Passenger

a. The handling agents at where Corendon Airlines flights are operated are required to display, at check-in, a clearly legible notice as follows, in a manner clearly visible to passengers:

A text of “If you are denied boarding or if your flight is cancelled or delayed for at least two hours, ask at the check-in counter or boarding gate for the text stating your rights, particularly with regard to compensation and assistance”.

b. In case of denied boarding, flight cancellation or a delay of more than 2 hours, each passenger shall be provided with a written notice setting out the rules for compensation and assistance. This notice must be given to the passenger after a delay of 2 hours.

c. The handling agent will use the relevant Corendon Airlines notices and forms mentioned above in “b” and “c”, when provided. These forms and notices shall include the contacts of the Turkish Directorate General of Civil Aviation (SHGM) and Corendon Airlines Complaints Management Department.

d. The handling agents are required to demand ‘Air Passenger Rights’ leaflets and placards from Corendon Airlines 2 weeks before they run out.

### 11.3 HANDLING IRREGULARITIES AND SPECIALS

Delays inevitably cause inconveniences. Corendon Airlines will take the upmost care and attention prevent delays and irregularities. Some of these are visible to passengers, such as passenger information and passenger welfare, and others less visible such as communication and coordination.

#### 11.3.1 Information to passengers

Timely, accurate and truthful information is the single most important aspect of handling a delayed flight.

- Passengers must be kept informed regularly and completely;
- If the probable length of a delay is unknown, then passengers are to be told;
- In announcements passengers are to be informed of any updates and additional information in 30 minute intervals and repeat these updates if necessary;
- Do not delay in making an announcement until you have something definite to tell them;
- Do not avoid contact with passengers;
- If no monitors are available, an information sheet should be visible at the check-in counter, to provide sufficient and correct information to passengers;

As soon as a delay becomes apparent - and throughout a delay situation - inform Antalya (AYT) Ground Operations.

In theory, passenger welfare is the responsibility of the airline. In practice, it concerns all parties involved in airport operations, and tour operator representatives can provide assistance, from providing vouchers to arranging coach transfers or diverting passengers to hotel accommodation instead of bringing them to the airport.

#### **11.4 SERVICES PROVIDED TO PASSENGERS IN CASE OF DENIED BOARDING (DBC) / FLIGHT CANCELLATION OR DELAY**

In case of denied boarding, flight cancellation or a delay of more than 2 hours, each passenger shall be provided with a written notice setting out the rules for compensation and assistance. This notice has to be given to the passenger after a delay of 2 hours and shall include the contacts of the Turkish Directorate General of Civil Aviation (SHGM) and Corendon Airlines Complaints Management Department.

Within the regulations of air passenger rights except where boarding is denied due to health, safety, security, unsuitable travel documentation or similar conditions, the rights of passengers in case of cancellation, delay of the flight or denied boarding for those who arrive at the check-in counter not later than 45 minutes before the published flight time and have a valid ticket are presented below.

Priority is given and particular attention is paid to the needs of persons with reduced mobility and any persons accompanying them or guide dogs, as well as to the needs of unaccompanied children in case of denied boarding, cancellation and delay.

##### **11.4.1 Denied Boarding (DBC)**

Rights of the Denied Passengers having Valid Tickets/Approved Reservation for Boarding

Except for the denied boarding due to reasonable causes such as health, safety, security, improper travel documents; in the event that a denied boarding is envisaged on a flight, firstly an announcement shall be made to find volunteers who shall waive their reservations on the relevant flight against certain benefits. The passenger who accepts to volunteer shall be entitled either:

- a. To be refunded for the ticket or to return to the original departure point at the first opportunity free of charge,
- b. To change the route to the final destination point,
- c. To change the route under the similar transportation conditions.

In the event that sufficient number of volunteers does not exist;

- Passengers shall be entitled to receive a compensation at the amount specified in "TABLE 2":
- For refunding or rerouting rights, one of the following options shall be provided;
  - a. To be refunded for the ticket or to return to the original departure point at the first opportunity,
  - b. To change the route to the final destination point,
  - c. To change the route under the similar transportation conditions.
- Besides this, the appropriate services in "TABLE 1" below shall be offered to the passengers free of charge.

##### **11.4.2. Cancellation of Flight**

Rights of the Passengers under Regulation on Passenger Rights in case of Cancellation of flight

- Passengers may select one of the following rights:
  - a. To be refunded for the ticket or to return to the original departure point,

- b. To change the route to the final destination point under the similar transportation conditions,
- c. To change the route under the similar transportation conditions.

- Appropriate services in “TABLE 1” below shall be offered to the passengers free of charge.
- Besides this, passengers shall be entitled to receive a compensation at the amount specified in “TABLE 2”:

**11.4.3 Delay**

In case of a delay, the action to be taken shall be as follows upon confirmation by Ground Operations Department who is expected to contact the representative of the relevant tour operator. The following procedures shall be applied:

**Rights of Passengers in case of Delay of the Flights**

In case of a delay the passengers shall be entitled to benefit free of charge from the services shown in TABLE 1, specified according to their flight distance:

**TABLE 1**

Duration for the delay	Type of service to each passenger
Between 2 and 3 hours	Snack or meal & hot/cold drinks and two free telephone calls, telex or fax messages, or e-mails should be provided to the passengers.
Between 3 and 5 hours	Depending on the time of day, breakfast or meal & hot/cold drinks and two free telephone calls, telex or fax messages, or e-mails should be provided to the passengers.
5 hours and more	Depending on the time of day, breakfast or meal & hot/cold drinks, additional hot and cold drinks and additional light snack and two free telephone calls, telex or fax messages, or e-mails should be provided to the passengers. *If the duration of the delay makes hotel accommodation necessary, corresponding information will be given by the OCC. This will be done in full co-ordination with the tour operator’s headquarters and/or its local representative.
Accommodation to the passengers	Accommodation is provided for delays of 6 hours or more between 20:00 p.m. and 07:00 a.m. Transportation between the airport and the accommodation (hotel or similar).
Denied boarding, over sale, flight cancellation	The representative of the tour operator should be contacted to transport the passenger to the destination. For each case, instructions from Ground Operations Department shall be followed.

**Note:** The voucher value should be discussed with Corendon GROUND OPERATION department

**11.4.4. Payable and non-payable amounts in case of Denied Boarding (DBC) / Flight Cancellation and/or Delay****“TABLE 2”**

<b>RIGHT TO COMPENSATION</b>	<b>COMPENSATION</b>
One-Off Flights	Turkish Lira equivalent 100 EURO
For all flights of 1500 km (including) or shorter	Turkish Lira equivalent 250 EURO
For flights between 1500 and 3500 km	Turkish Lira equivalent 400 EURO
For flights longer than 3500 km	Turkish Lira equivalent 600 EURO

\*If the delay is at least five hours and the passengers waive the flight, they may be refunded the full ticket price and benefit from the right to be returned to the original departure point free of charge.

\*In case an alternative flight is offered for which the final destination time does not exceed the durations: 2 hours, 3 hours and 4 hours, 50% of the compensation amount is given.

**The cases where compensation is not payable:**

→ If passengers are informed of the cancellation or delay at least two weeks before the scheduled time of departure; or

→ If passengers are informed of the cancellation between one and two weeks' prior and are offered re-routing, allowing them to depart **not** more than two hours before the scheduled time of departure and to reach their final destination less than four hours after the scheduled time of arrival; or

→ If passengers are informed of the cancellation less than a week before the scheduled time of departure and are offered re-routing, allowing them to depart no more than one hour before the scheduled time of departure and to reach their final destination less than two hours after the scheduled time of arrival; or

→ Airline Companies do not pay compensation for delay in extraordinary circumstances such as political instability, adverse meteorological conditions, natural disasters, security risks, unexpected flight safety deficiencies, strikes, etc.

→ If the delay is due to technical reasons and of more than 5 hours and when the passengers misses their connection flight, compensation has to be paid to these passengers.

→ Delays and cancellations due to technical or organizational reasons are not accepted as extraordinary circumstances.

**11.5 UPGRADING & DOWNGRADING**

If an operating air carrier places a passenger in a class higher than that for which the ticket was purchased, it may not request any supplementary payment.

If an operating air carrier places a passenger in a class lower than that for which the ticket was purchased, it shall within seven days reimburse.

- 30 % of the price of the ticket for all flights of 1 500 kilometers or less, or
- 50 % of the price of the ticket for all other flights between 1 500 and 3 500 kilometers, or
- 75 % of the price of the ticket for all flights of longer than 3 300 kilometers.



## GROUND OPERATION MANUAL

Doc Code: CA-GOP-GOM

Rev No: 45

Rev Date: 01 APR 2026

Page: 256

**INTENTIONALLY LEFT BLANK**